



टाटा मूलभूत अनुसंधान संस्थान
TATA INSTITUTE OF FUNDAMENTAL RESEARCH
भारत सरकार के परमाणु ऊर्जा विभाग की स्वायत्त संस्था एवं समविश्वविद्यालय
(Autonomous Institution of the Department of Atomic Energy, Government of India)
सर्वेक्षण संख्या 36 / पी, गोपनपल्ली गांव, सेरिलिंगमपल्ली मंडल, रंगारेड्डी जिला, हैदराबाद - 500 046
Survey No.36/P, Gopanpally Village, Serilingampally Mandal, Ranga Reddy District,
Hyderabad-500046, Telangana

दूरभाष / Telephone: +91-40-20203009	दिनांक / Date: 21-05-2024
वेबसाइट / Website: www.tifrh.res.in	ईमेल / Email: krishnaae@tifrh.res.in

निविदा आमंत्रित करने की सूचना

NOTICE INVITING TENDER

(दो भाग निविदा) निम्नलिखित कार्यों के लिए:

(TWO-PART TENDER) for the following works:

Setting up of “500 KWp Grid-connected Rooftop Solar PV Power Plant under RESCO mode” at TIFR, Survey No. 36/P, Gopanpally (Village), Serilingampally (Mandal), Ranga Reddy Dist., Hyderabad-500046 including Operation & Maintenance (O & M) of the project for a period of 25 (Twenty-five) years after operational acceptance”.	
निविदा सं. / Tender No.	TIFR/PD/CF24-17/240087
निविदा का प्रकार / Type of Tender	दो भाग की निविदा (भाग-I: तकनीकी बोली और भाग-II: मूल्य बोली)/Two-Part Tender (Part-I: Technical Bid and Part-II: Price Bid)
अनुमानित लागत / Cost of EMD	रु. Rs. 5,00,000/- ("मांग ड्राफ्ट "टीआईएफआर सेंटर फॉर इंटरडिसिप्लिनरी साइंसेज" हैदराबाद में देय (तकनीकी बोली भाग-I के साथ संलग्न होने के लिए) के पक्ष में तैयार किया जाना है।" Demand Draft to be drawn in favour of “TIFR Center for Interdisciplinary Sciences”, Payable at Hyderabad (To be enclosed with the Technical Bid Part – I).
बोली पूर्व बैठक और समय/ Pre-bidding meeting & Time	28-05-2024 at 11:00 Hrs (The bidder is required to furnish authorization letter along with the employee id card to participate in the Pre-bid Meeting)
निविदा प्रस्तुत करने की अंतिम तिथि/ Last Date for Submission of Tender	13-06-2024 Up to 13:00 Hrs
बोली खोलने की तिथि (केवल भाग-I: तकनीकी बिड) / Date of Opening Bids(Only Part-I: Technical Bid)	13-06-2024 at 15:00 Hrs
निविदा शुल्क/ Tender Fee	रु. Rs.1000/- ("मांग ड्राफ्ट "टीआईएफआर सेंटर फॉर इंटरडिसिप्लिनरी साइंसेज" हैदराबाद में देय (तकनीकी बोली भाग-I के साथ संलग्न होने के लिए) के पक्ष में तैयार किया जाना है।" Demand Draft to be



टाटा मूलभूत अनुसंधान संस्थान
TATA INSTITUTE OF FUNDAMENTAL RESEARCH
भारत सरकार के परमाणु ऊर्जा विभाग की स्वायत्त संस्था एवं समविश्वविद्यालय
(Autonomous Institution of the Department of Atomic Energy, Government of India)
सर्वेक्षण संख्या 36 / पी, गोपनपल्ली गांव, सेरिलिंगमपल्ली मंडल, रंगारेड्डी जिला, हैदराबाद - 500 046
Survey No.36/P, Gopanpally Village, Serilingampally Mandal, Ranga Reddy District,
Hyderabad-500046, Telangana

drawn in favor of "TIFR Center for Interdisciplinary Sciences "Payable at Hyderabad (To be enclosed with the Technical Bid Part –I)).

- "यदि भाग "I" और भाग "II" बोलियों को अलग-अलग लिफाफों में सील नहीं किया जाता है तो निविदा को अस्वीकार कर दिया जाएगा।"
In case the Part "I" and Part "II" bids are not sealed in separate envelopes the tender will be rejected.
- तकनीकी बोली में मूल्य का कोई संकेत नहीं होना चाहिए।
The technical bid should not contain any indication of the price.
- निविदा शुल्क और ईएमडी के भुगतान के बिना प्राप्त तकनीकी बोली को सरसरी तौर पर अस्वीकार कर दिया जाएगा।
The Technical Bid received without payment of tender fees and EMD shall be summarily rejected.
- संपर्क: श्री कृष्ण, दूरभाष: 040- 20203009 किसी भी तकनीकी या वाणिज्यिक शर्तों के लिए निविदा में उल्लिखित स्पष्टीकरण Contacts: Mr. Krishna A.E., Engineer (E) Electrical, Tel: 040-20203009, Email Id: krishnaae@tifrh.res.in for any technical or commercial terms clarifications mentioned in the tender.

Sealed tenders are invited for the aforesaid works from contractors having similar work experience in reputed Research Institutions, Universities, Central Government/Public Sector Undertaking, Private Laboratories, Multinational Companies, etc. Interested contractors who are satisfying prequalification criteria stipulated by TIFR-Hyderabad shall only submit their bids. For further details and any clarification on the tender, you may please contact Head-Technical Services, Survey No.36/P, Gopanpally Village, Serilingampally Mandal, Ranga Reddy District, Hyderabad-500046.

निविदा जमा करने की अंतिम तिथि **13.06.2024** को **13:00** बजे तक है।

The last date for submission of the tender is 13-06-2024 by 13:00 Hrs.

(राजशेखर आर/Rajasekhar. R)

प्रमुख - तकनीकी सेवाएं/Head-Technical Services



टाटा मूलभूत अनुसंधान संस्थान
TATA INSTITUTE OF FUNDAMENTAL RESEARCH
भारत सरकार के परमाणु ऊर्जा विभाग की स्वायत्त संस्था एवं समविश्वविद्यालय
(Autonomous Institution of the Department of Atomic Energy, Government of India)
सर्वेक्षण संख्या 36 / पी, गोपनपल्ली गांव, सेरिलिंगमपल्ली मंडल, रंगारेड्डी जिला, हैदराबाद - 500 046
Survey No.36/P, Gopanpally Village, Serilingampally Mandal, Ranga Reddy District,
Hyderabad-500046, Telangana

TENDER DOCUMENT

Setting up of “500 KWp Grid-connected Rooftop Solar PV Power Plant under RESCO mode” at TIFR, Survey No. 36/P, Gopanpally (Village), Serilingampally (Mandal), Ranga Reddy Dist., Hyderabad-500046 including Operation & Maintenance (O & M) of the project for a period of 25 (Twenty-five) years after operational acceptance”.

NAME OF THE TENDERER:.....

Address:

.....

.....

.....

Last date of submission of the tender: On or before 13-06-2024 by 13:00 Hrs.



टाटा मूलभूत अनुसंधान संस्थान
TATA INSTITUTE OF FUNDAMENTAL RESEARCH
भारत सरकार के परमाणु ऊर्जा विभाग की स्वायत्त संस्था एवं समविश्वविद्यालय
(Autonomous Institution of the Department of Atomic Energy, Government of India)
सर्वेक्षण संख्या 36 / पी, गोपनपल्ली गांव, सेरिलिंगमपल्ली मंडल, रंगारेड्डी जिला, हैदराबाद - 500 046
Survey No.36/P, Gopanpally Village, Serilingampally Mandal, Ranga Reddy District,
Hyderabad-500046, Telangana

TECHNICAL BID

VOLUME-I

Setting up of “500 KWp Grid-connected Rooftop Solar PV Power Plant under RESCO mode” at TIFR, Survey No. 36/P, Gopanpally (Village), Serilingampally (Mandal), Ranga Reddy Dist., Hyderabad-500046 including Operation & Maintenance (O & M) of the project for a period of 25 (Twenty-five) years after operational acceptance”.



टाटा मूलभूत अनुसंधान संस्थान
TATA INSTITUTE OF FUNDAMENTAL RESEARCH
भारत सरकार के परमाणु ऊर्जा विभाग की स्वायत्त संस्था एवं समविश्वविद्यालय
(Autonomous Institution of the Department of Atomic Energy, Government of India)
सर्वेक्षण संख्या 36 / पी, गोपनपल्ली गांव, सेरिलिंगमपल्ली मंडल, रंगारेड्डी जिला, हैदराबाद - 500 046
Survey No.36/P, Gopanpally Village, Serilingampally Mandal, Ranga Reddy District,
Hyderabad-500046, Telangana

Tender Notice	:	TIFR/PD/CF24-17/240087
Name of Work	:	Setting up of “500 KWp Grid-connected Rooftop Solar PV Power Plant under RESCO mode” at TIFR, Survey No. 36/P, Gopanpally (Village), Serilingampally (Mandal), Ranga Reddy Dist., Hyderabad-500046 including Operation & Maintenance (O & M) of the project for a period of 25 (Twenty-five) years after operational acceptance”.
Location	:	Tata Institute of Fundamental Research Survey No. 36/P, Gopanpally village, Serilingampally Mandal, Ranga Reddy District, Hyderabad – 500046.
Delivery Period	:	120 Days (Completion Period)
Validity	:	Seventy Five (75) days after the opening of Part-I, Technical Bid



INDEX

SECTION	DESCRIPTION	PAGE NO.
SECTION I	NOTICE INVITING TENDER	7-12
SECTION II	TECHNICAL SPECIFICATIONS	13-26
SECTION III	INFORMATION AND INSTRUCTIONS FOR BIDDERS	27-31
SECTION IV	ANNEXURES	32-47
SECTION V	GENERAL CONDITIONS OF CONTRACT	48-53
SECTION VI	PRICE BID (PART II)	54-71



SECTION-I

NOTICE INVITING TENDER

NOTICE INVITING TENDER

Tenders are invited by the TIFR-Hyderabad from reputed contractors in single-stage two cover bidding procedure [Technical Bid and Financial bid], meeting the Minimum Eligibility Criteria specified below for the work of “**Setting up of “500 KWp Grid-connected Rooftop Solar PV Power Plant under RESCO mode”** on the rooftop of various buildings of TIFR-Hyderabad, including Operation & Maintenance (O & M) of the project for a period of 25 (Twenty Five) years under RESCO model after operational acceptance”.

1.0 MINIMUM QUALIFICATION CRITERIA (MQC)

Tenderer must fulfill the following minimum qualifying criteria to prove the techno commercial competence and submit the documents in support thereof:

1.1 Experience Bidders who fulfill either category A or Category B with the following requirements shall be eligible to apply. Bidders should have satisfactorily completed the works in any Govt./Semi Govt./Corporations/Private sector organizations as mentioned below during the last five years ending up to the previous day of the last date of submission of tender as per Annexure – I.

Category A:

- (a) One (1) completed work and successfully running from last 24 months under RESCO model not less than the 400kWp rooftop solar plant OR
- (b) Two (2) completed works and successfully running from last 24 months under RESCO model, each single project of capacity not less than 300kWp rooftop Solar plant OR
- (c) Three (3) completed works and successfully running from the last 24 months under RESCO model, each single project of capacity not less than 200kWp rooftop Solar plant.

(OR)

Category B:

- (a) One (1) completed work and successfully running for last 24 months under EPC model not less than the 5MWp rooftop solar plant OR
- (b) Two (2) completed works and successfully running for last 24 months under EPC model, each single project of capacity not less than 4 MWp rooftop Solar plant OR
- (c) Three (3) completed works and successfully running for last 24 months under EPC model, each single project of capacity not less than 3 MWp rooftop Solar plant.



Bidders come under category – B, should have Maintenance/AMC experience of rooftop solar for a minimum of 1 year, for which relevant experience documents to be submitted along with the bid. Ongoing/Partwork will not be considered for the technical evaluation.

The work executed as a sub-contractor or subletting agency shall not be taken into consideration.

Note: For the purpose of similar works, works executed in India only shall be considered and Annexure – I and Annexure - II shall be submitted along with the necessary supporting documents for evaluation of Technical Bid. The experience of work carried out under subcontract to the main contractor will not be considered. As a part of the technical evaluation a team from TIFR-Hyderabad may inspect the sites, where the solar rooftop systems are established by the bidder working in RESCO model. Bidders should not be blacklisted by any Central Government/State Government/Autonomous bodies. Undertaking to be submitted in Annexure – III.

1.2 Financial Eligibility Criteria Average annual financial turnover during the last five (5) financial years of the bidder, shall not be less than Rs. 2 crores (whereas Rs. 6.25 crores in case the bidder comes under eligibility of category B) and the bidder shall submit the Annual turnover certificate during the last 5 financial years, 2018-19, 2019-20, 2020-21, 2021-22, 2022-23 duly certified by a Chartered Accountant. This may be furnished in the Proforma in “Annexure-IV” of the tender document.

1.3 License The tenderer shall hold a valid “A-Class” license or should have a tie-up with a firm having an “A-Class” license issued by the competent authority. A copy of the license shall be submitted along with the tender or furnish an undertaking that the tenderer shall tie up with a contractor having an “A-Class” license in case of award of contract.

2.0 Even though the tenderers meet the above qualifying criteria, they are subjected to be disqualified if they have:

1. Made misleading or false representations in the forms, statements, and attachments submitted in proof of the qualification requirements; and/ or
2. Record of poor performance such as abandoning the works, not properly completing the contract, inordinate delays in completion, litigation history or financial failures, etc.

3.0 Pertinent information to the tender is given in the following tables:

(i) Bid information:



टाटा मूलभूत अनुसंधान संस्थान
TATA INSTITUTE OF FUNDAMENTAL RESEARCH
भारत सरकार के परमाणु ऊर्जा विभाग की स्वायत्त संस्था एवं समविश्वविद्यालय
(Autonomous Institution of the Department of Atomic Energy, Government of India)
सर्वेक्षण संख्या 36 / पी, गोपनपल्ली गांव, सेरिलिंगमपल्ली मंडल, रंगारेड्डी जिला, हैदराबाद - 500 046
Survey No.36/P, Gopanpally Village, Serilingampally Mandal, Ranga Reddy District,
Hyderabad-500046, Telangana

1)	NIT No. & Date	TIFR/PD/CF24-17/240087
2)	Document Description	<p>i) The tender document comprises “Bidding process for Site survey, Design, Engineering, Supply, Storage, Civil Works, Installation, Testing & Commissioning of 500 kWp grid connected rooftop solar PV project on the rooftop of various academic buildings of TIFR-Hyderabad including Operation & Maintenance (O & M) of the project for a period of 25 (Twenty-five) years under RESCO model after operational acceptance”.</p> <p>ii) Before submission of bid, the bidder shall visit the site with prior intimation for any clarifications/estimation purpose.</p>
3)	Validity period of tender	75 days from the last date for receipt of tenders
4)	Completion period for installation of solar power plant	120 Days
5)	Milestone completion activity	Shall be completed on all buildings shall be commissioned within 120 Days from the date of Notice to Proceed.
6)	Earnest Money Deposit (EMD)	EMD of Rs 5,00,000 (Rupees Five Lakhs only) should be submitted in ECS (Bank Transfer/NEFT/RTGS) in favour of “TIFR Center for Interdisciplinary Sciences” Payable at Hyderabad
7)	Performance Security	Performance Security amount of Rs. 10,00,000/- (Ten lakhs only), should be furnished by the successful bidder within 7 days of issue of Letter of Acceptance (LoA) by TIFR-Hyderabad. Clause 8 to be referred for further details.
8)	Price Bid	Price Bid to be submitted as per the Section (VI) conditions



टाटा मूलभूत अनुसंधान संस्थान
TATA INSTITUTE OF FUNDAMENTAL RESEARCH
भारत सरकार के परमाणु ऊर्जा विभाग की स्वायत्त संस्था एवं समविश्वविद्यालय
(Autonomous Institution of the Department of Atomic Energy, Government of India)
सर्वेक्षण संख्या 36 / पी, गोपनपल्ली गांव, सेरिलिंगमपल्ली मंडल, रंगारेड्डी जिला, हैदराबाद - 500 046
Survey No.36/P, Gopanpally Village, Serilingampally Mandal, Ranga Reddy District,
Hyderabad-500046, Telangana

9)	Engineer In-Charge, Designation, Address and other details (For Submission of Bid in response to NIT)	
----	---	--

Important Note: Prospective Bidders are requested to remain updated for any corrigendum/ amendments/ clarifications etc. to the bid document through the CPP & website. No separate notifications will be issued for such corrigendum /amendments/clarification etc. in the print media or individually. All the information related to this NIT shall be updated in the websites <https://eprocure.gov.in/eprocure/app> and <https://www.tifrh.res.in/tender/>. The tariff to be quoted by the bidder for 25 years shall be firm. No taxes, duties etc, is payable by TIFR-Hyderabad. No price variation whatsoever is applicable. The rate should be firm for the entire period of 25 years, including all taxes and duties.

Please note that any queries related to the subject tender may be sent to the krishnaae@tifrh.res.in meeting/clarification end date. before pre-bid.

4.0 The tenders should be submitted under a single stage, two part tender mode in accordance with the Technical Specification, General Conditions of contract and Scope of work, etc, as enumerated in the Bidding Documents and to be submitted in hard copy at the security of TIFR-Hyderabad.

5.0 Other important information and instructions.

1. The bid document consisting of roof terrace plan, specifications, and the set of terms and conditions of the contract to be complied with and other necessary documents if any can be seen in the office of the Head-Technical Services, TIFR-Hyderabad during the office hours on all days except on Saturday, Sunday & Public holidays and also can be downloaded free of cost from <https://eprocure.gov.in/eprocure/app> and <https://www.tifrh.res.in/tender/>.

2. Applicants are advised to keep visiting the above-mentioned web-sites from time to time (till the deadline for bid submission) for any updates in respect of the tender documents, if any. Failure to do so shall not absolve the applicant of his liabilities to submit the applications complete in all respects including updates thereof, if any. An incomplete application may be liable for rejection.

3. Those contractors who have not registered on the website mentioned above, are required to get registered themselves beforehand.

4. The department reserves the right to reject any prospective application without assigning any reason thereof and to restrict the list of qualified bidders to any number deemed suitable by it, if too many bids are received satisfying the laid down criteria.



5. If this work requires engaging more than 20 nos. of labors/workers and therefore all necessary licenses such as Labour license, EPFO and ESI, BOCW welfare registration etc., shall be taken by a contractor.
6. If any information furnished by the applicant is found to be incorrect at a later stage, he shall be liable to be debarred from tendering/taking up of works in TIFR-Hyderabad. The department reserves the right to verify the particulars furnished by the applicant independently.
7. The bidder should not have been barred/blacklisted by the central/State Government/PSU, or any entity controlled by it, from participating in any tender, and the bar subsists as on the Bid Due Date, such bidder would not be eligible to submit the BID.
8. Any dispute arising out of this tender including dispute related to encashment of any Bank Guarantee/ FDR etc. shall be subject to the jurisdiction of courts of Hyderabad only.

6.0 Submission of Bids

1. Bids shall be submitted to Head- Technical Services, **TIFR, Survey No. 36/P, Gopanpally (Village), Serilingampally (Mandal), Ranga Reddy Dist, Hyderabad-500046** in a sealed Master envelope super scribed “Bid for **Setting up of “500 KWp Grid-connected Rooftop Solar PV Power Plant under RESCO mode” at TIFR, Survey No. 36/P, Gopanpally (Village), Serilingampally (Mandal), Ranga Reddy Dist., Hyderabad-500046 including Operation & Maintenance (O & M) of the project for a period of 25 (Twenty-five) years after operational acceptance”**.. with our enquiry no. and due date, containing two separate sealed covers clearly super scribed as “**Technical Bid**” and “ **Financial Bid**” before the closing date and time of submission in the following manner:

- a) “**Technical Bid**”: This will contain Technical part, Eligibility Documents along with testimonials. Earnest Money Deposit (EMD).
- b) “**Financial Bid**”: This will contain the complete bidding document with duly filled in Schedule of Financial Quote of Financial Bid & Tender Drawings.

The Bids without signature of the authorized person of bidder and seal, without EMD, with conditions or conditional rebates shall be summarily rejected.

2. The tenderer is responsible to download Addendums/ Amendments/ Errata/ Replies to the queries of the tenderer etc., if any, issued by the Institute, from the website before submission of the bid. Any shortfall in submissions of the said Addendums/ Amendments/Errata/Replies to the queries of the tenderer duly signed etc. along with the downloaded documents while submitting the bid will not be considered. Incomplete tenders will be rejected.



3. Latest MNRE guidelines shall be enforced/ followed for the details not explicitly mentioned/ elaborately specified in this tender document for rooftop solar RESCO model.

7.0 Successful Bidder(S) Selection

1. Bidders meeting the Minimum qualification criteria qualified and technically qualified are only considered for opening the price bid.
2. Based on the price bid quoted by the qualified bidders. The lowest bidder will be declared as the successful bidder.
3. Letter(s) of Acceptance (LoA): The Letter(s) of Acceptance (LoA) shall be issued to the Successful Bidders(s) selected.
4. Successful Bidder shall acknowledge the LoA and return duplicate copy with signature & stamp of the authorized signatory of the Successful Bidder to the TIFR-Hyderabad within 7 days of issue of LoA.
5. TIFR-Hyderabad at its own discretion, has the right to reject any or all the Bids without assigning any reason whatsoever, at its sole discretion.

8.0 Performance Security / Performance Bank Guarantee (PBG)

1. Within 7 days from the date of issue of Letter of Acceptance (LoA), Successful Bidder shall furnish the Performance Security for the amount of Rs 10 Lakhs.
2. The Performance Security shall be denominated in Indian Rupees and shall be in one of the following forms:
 - a. a demand draft, or a bank guarantee
 - b. BG will be confirmed for payment by the branch of the bank giving BG
3. The Performance Security/PBG shall be forfeited as follows without prejudice to the Bidder being liable for any further consequential loss or damage incurred to TIFR-Hyderabad.
 - a. If the Successful Bidder is not able to commission the projects to the satisfaction of TIFR-Hyderabad, within the completion date or extended date as provided under Clause No 12, under Information and Instruction for Bidders, the Performance security/PBG will be forfeited as per clause 12 on pro-rata basis for a period of 6 months and 100% performance security/PBG will be forfeited on expiry of such period for partial completion of project within the completion period or extended completion period.
4. The Performance Security shall be valid for a minimum period of 12 months from the date of issue of Letter of Acceptance (LoA) and shall be renewed/extended till the completion of 25 years of O&M from the date of commissioning.

(Rajasekhar R)
Head-Technical Services



SECTION-II

TECHNICAL SPECIFICATIONS

TECHNICAL SPECIFICATIONS

About TIFR-Hyderabad: The Tata Institute of Fundamental Research (TIFR) is a National Centre of the Government of India, under the umbrella of the Department of Atomic Energy, as well as a deemed University awarding degrees for master's and doctoral programs.

1. Details of Scope of Work:

- 1.1. Site survey, Design, Engineering, Supply, Storage, Civil Works, Installation, Testing & Commissioning of 500kWp grid-connected rooftop solar PV project on the rooftop of various buildings of TIFR-Hyderabad, including Operation & Maintenance (O & M) of the project for a period of 25 (Twenty Five) years under RESCO model after operational acceptance”.
- 1.2. The solar panels used in the Solar PV System shall be non-reflective type.
- 1.3. TIFR-Hyderabad will only provide the space on each building terrace. List of buildings are mentioned in the table under clause 1.6. Further any additional structures, Beams, foundations for solar structure, foundation Bolts etc. is in the scope of the bidder.
- 1.4. The bidder is advised to visit the site of work, at his own cost, and examine it and its surroundings to satisfy himself and collect all information that he considers necessary for proper assessment of the prospective assignment.
- 1.5. The proposed rooftop solar plant capacity of 500kWp to be synchronized with the LT grid at 433V level of the same existing power distribution level and shall work on net metering at 33 kV level. All necessary statutory approvals, registration at Telangana State Renewable Energy Development corporation Limited (TSREDCO) and coordination with TSSPDCL for obtaining Net Metering is under the scope of the bidder. Bidder to visit the site for analyzing the existing solar rooftop so as to ensure hassle-free operations.
- 1.6. Bidders shall ensure proper synchronization with the respective LT DG sets in the campus.
- 1.7. The Solar PV System shall be installed, operated and maintained at TIFR-Hyderabad on the rooftop of the buildings mentioned below in the table under RESCO MODEL for a period of Twenty-Five (25) years.



टाटा मूलभूत अनुसंधान संस्थान
TATA INSTITUTE OF FUNDAMENTAL RESEARCH
भारत सरकार के परमाणु ऊर्जा विभाग की स्वायत्त संस्था एवं समविश्वविद्यालय
(Autonomous Institution of the Department of Atomic Energy, Government of India)
सर्वेक्षण संख्या 36 / पी, गोपनपल्ली गांव, सेरिलिंगमपल्ली मंडल, रंगारेड्डी जिला, हैदराबाद - 500 046
Survey No.36/P, Gopanpally Village, Serilingampally Mandal, Ranga Reddy District,
Hyderabad-500046, Telangana

S.No.	Name of Building	Terrace/roof area in sq.mtrs
1	Main Building	60
2	Service Building-1	56
3	Service Building-2	36
4	Hostel-1	50
5	Hostel-2	80
6	Hostel-3	68
7	Hanger-1	39
8	Hanger-2	45
9	Petawatt	90
10	Car Parking	45
	Total in kWp	569

Note: Bidder to make use of maximum terrace area to achieve 500kWp output. In the bid document, 85% of the rooftop is considered to achieve 500kWp on the above three buildings. However, bidder to Visit TIFR-Hyderabad site and assess the space of the above three building terrace. Building wise Average power that can be generated to be submitted by the bidder along with a bid document in Annexure – XII, without which the bid will lead to rejection/ disqualification. If the bidder is not able to achieve 500kWp on the buildings specified above, bidder to raise the same during the Prebid clarification.

- 1.8. TIFR-Hyderabad shall offer Roof-top for the duration of the contract period without any charge. Respective building Terrace drawing to referred for the details.
- 1.9. State of art plant efficiency monitoring and data logging system will be an integral part of the Solar PV System. TIFR-Hyderabad should be able to do diagnostics & monitor all plant efficiency-related parameters.
- 1.10. Net Metering and grid connectivity of the solar PV system under this scheme would be the responsibility of the Bidder in accordance with the prevailing guidelines of the concerned DISCOM. TIFR-Hyderabad could facilitate connectivity as and wherever possible; however, the entire responsibility lies solely with Bidder.



- 1.11. Monthly billing will be done by Bidder for the number of units generated by the system as per the agreed tariff and billing mechanism.
- 1.12. Bidder shall bear whole Project costs such as cost of engineering, procurement, Installation, commissioning, operation and subsequent up-gradation and maintenance of Solar PV System for twenty-five (25) years including all costs such as operation & maintenance cost, insurance premium, administrative, logistic cost etc.
- 1.13. All EPC work including the transportation of material and machinery to and from the Project Site will be the responsibility of the Bidder.
- 1.14. Bidders should be ISO certified in their capacity as a Solar developer and shall carry out all works under the Project up to the said ISO standards.
- 1.15. Bidders shall bear all risks of loss and damage to any part of the Solar P V System due to conditions not on account of TIFR-Hyderabad.
- 1.16. Bidders shall be liable to guarantee a minimum number of units of electricity that it shall supply annually. The guarantee shall be 93% of output during the first 15 years and 85% of output for the next succeeding 10 years. If the guarantee output is not achieved, the bidder should pay the per unit tariff/charges as per prevailing rates of DISCOMS.
- 1.17. Bidders shall submit technical details like Generation estimate, preliminary system design used along with the tentative bill of material such as panel, inverter make etc.
- 1.18. All required cabling from the rooftop till the existing electrical panel room is in the scope of bidder.
- 1.19. The erection of the solar PV system shall be done without causing any damage to the existing structure. Any damage to the structure should be repaired, under direction from TIFR-Hyderabad at the cost of the selected bidder.
- 1.20. Bidder to submit the drawings and technical data sheets/GTP of the solar PV, Invertors, ACDB, DCDB, Structures, Any other layouts for approval within 10 days from the data of LoA.

2. SPECIFICATIONS

- 2.1. Introduction. The proposed project shall be commissioned as per the technical specifications given below.
- 2.2. Definition: A Grid Tied Rooftop Solar Photo Voltaic (SPV) power plant consists of SPV array, Module Mounting Structure, Power Conditioning Unit (PCU) consisting of Maximum Power Point Tracker (MPPT), Inverter, and Controls & Protections, interconnect cables and switches. PV Array is mounted on a suitable structure. Grid tied SPV system is without battery and should be designed with necessary features to supplement the grid power during daytime. Components and parts used in the SPV power plants including the PV modules, metallic structures, cables, junction box, switches, PCUs etc., should conform to the relevant standards, wherever such specifications are available and applicable.



- 2.2.1.1. Solar PV system shall consist of the following equipment/components.
- a) Solar PV modules consisting of the required number of Crystalline PV Cells.
 - b) Grid interactive Power Conditioning Unit with Remote Monitoring System.
 - c) Mounting structures.
 - d) Junction Boxes.
 - e) Earthing and lightning protections.
 - f) IR/UV protected PVC Cables, pipes and accessories
- 2.2.1.2. Solar Photovoltaic Modules
- a) The PV modules used must qualify to the latest edition of relevant standards.
 - b) The PV modules to be used in a highly corrosive atmosphere throughout their lifetime, they must qualify to IS 61701.
 - c) The total solar PV array capacity should not be less than the allocated capacity (kW) and should comprise of solar crystalline modules of minimum 325Wp and above wattage. Module capacity less than the minimum of 325Wp will not be accepted. Modules shall be as per the approved list of MNRE (Ministry of New and Renewable Energy), Government of India.
 - d) SPV module conversion efficiency should be equal to or greater than 17%. SPV module, conversion efficiency less than 17% will not be acceptable.
 - e) Protective devices against surges at the PV module shall be provided. Low voltage drop bypass diodes shall be provided.
 - f) PV modules must be tested and approved by one of the authorized test centers and the certificates in this regard shall be furnished.
 - g) The module frame shall be made of corrosion-resistant materials, preferably having anodized aluminum.
 - h) The bidder shall carefully design & accommodate requisite numbers of the modules to achieve the rated power in his bid. TIFR-Hyderabad shall allow only minor changes at the time of execution.
 - a) Other general requirements for the PV modules and subsystems shall be the following:
 - I. The rated output power of any supplied module shall have positive tolerance of 5 watt.
 - II. The peak-power point voltage and the peak-power point current of any supplied module and/or any module string (series-connected modules) shall not vary by more than 2 (two) percent from the respective arithmetic means for all modules and/or for all module strings, as the case may be.
 - III. The module shall be provided with a junction box with either provision of external screw terminal connection or sealed type and with arrangement for the provision of the by-pass diode. The box shall have a hinged, weatherproof lid



with captive screws and cable gland entry points or maybe of sealed type and IP-65 rated.

IV. I-V curves at STC should be provided by the bidder.

- 2.2.1.3. Modules deployed must use an RF identification tag. The following information must be mentioned in the RFID used on each module (This can be inside or outside the laminate, but must be able to withstand harsh environmental conditions).
- i. Name of the manufacturer of the PV module
 - ii. Name of the manufacturer of Solar Cells.
 - iii. Month & year of the manufacture (separate for solar cells and modules)
 - iv. Country of origin (separately for solar cells and module)
 - v. I-V curve for the module Wattage, I_m , V_m and FF for the module
 - vi. Unique Serial No and Model No of the module
 - vii. Date and year of obtaining PV module qualification certificate.
 - viii. Name of the test lab issuing certificate.
 - ix. Other relevant information on traceability of solar cells and modules as per relevant standards.

2.3. Array Structure

a) Hot-dip galvanized MS mounting structures may be used for mounting the modules/ panels/arrays. Each structure should have angle of inclination as per the site conditions to take maximum isolation. However, to accommodate more capacity the angle inclination may be reduced until the plant meets the specified performance ratio requirements.

b) The Mounting structure shall be so designed to withstand the wind speed of 180 kmph. It may be ensured that the design has been certified by a recognized Lab/ Institution in this regard and submit a wind loading calculation sheet to TIFR-Hyderabad. Suitable fastening arrangements such as grouting and clamping should be provided to secure the installation against the specific wind speed.

c) The mounting structure steel shall be as per latest IS 2062: 1992 and galvanization of the mounting structure shall be in compliance with latest IS 4759.

d) Structural material shall be corrosion resistant and electrolytically compatible with the materials used in the module frame, its fasteners, nuts and bolts. Aluminum structures also can be used which can withstand the wind speed, as mentioned above in point no.

b. Necessary protection towards rusting needs to be provided either by coating or anodization.

e) The fasteners used should be made up of stainless steel. The structures shall be designed to allow easy replacement of any module. The array structure shall be so designed that it will occupy minimum space without sacrificing the output from the SPV panels



- f) Regarding civil structures, the bidder needs to take care of the load-bearing capacity of the roof and need to arrange suitable structures based on the quality of roof.
- g) The total load of the structure (when installed with PV modules) on the terrace should be less than 60 kg/m².
- 2.4. Junction Boxes (JBs)
- a) The junction boxes are to be provided in the PV array for the termination of connecting cables. The Junction Boxes (JBs) shall be made of GRP/FRP/Powder Coated Aluminium/cast aluminum alloy with full dust, water & vermin proof arrangement. All wires/cables must be terminated through cable lugs. The JB's shall be such that input & output termination can be made through suitable cable glands.
- b) Copper bus bars/terminal blocks housed in the junction box with suitable termination threads conforming to IP65, Hinged door with EPDM rubber gasket to prevent water entry. Single / double compression cable glands. Provision of earthings. It should be placed at 5 feet height or above for ease of accessibility.
- c) Each Junction Box shall have High quality Suitable capacity, Metal Oxide Varistors (MOVs) / SPDs, suitable Reverse Blocking Diodes. The Junction Boxes shall have suitable arrangement monitoring and disconnection for each of the groups.
- d) Suitable markings shall be provided on the bus bar for easy identification and the cable ferrules must be fitted at the cable termination points for identification.
- 2.5. DC Distribution Panel Board
- a) DC Distribution Panel Board to receive the DC output from the array field.
- b) DC DPBs shall have a sheet from enclosure of dust & vermin proof conform to IP 65 protection. The bus bars are made of copper of desired size. Suitable capacity MCBs/MCCBs shall be provided for controlling the DC power output to the PCU along with necessary surge protection devices.
- 2.6. AC Distribution Panel Board
- a) AC Distribution Panel Board (DPB) shall control the AC power from PCU/ inverter, and should have necessary SPD's. Interconnection from AC DB to mains at LT Bus bar while in grid tied mode.
- b) All switches and the circuit breakers, connectors should conform to relevant standards.
- c) The changeover switches, cabling work should be undertaken by the bidder as part of the project.
- d) All the Panel's shall be metal clad, totally enclosed, rigid, floor mounted, air - insulated, cubical type suitable for operation on three phase / single phase, 415 or 240 volts, 50 Hz



- e) The panels shall be designed for minimum expected ambient temperature of 45 Deg C, 80% humidity and dusty weather.
 - f) All indoor panels will have protection of IP54 or better. All outdoor panels will have protection of IP 65 or better.
 - g) Should conform to Indian Electricity Act and rules (till last amendment).
 - h) All the 415 AC or 240 volts devices / equipment like bus support insulators, circuit breakers, SPDs, VTs etc., mounted inside the switchgear shall be suitable for continuous operation and satisfactory performance under the following supply conditions
- | | |
|-------------------------------|----------|
| Variation in supply voltage | +/- 10% |
| Variation in supply frequency | +/- 5 Hz |

2.7. PCU/Array Size Ratio

- a) The combined wattage of all Inverters should not be less than the rated capacity of the power plant under STC.
- b) Maximum power point tracker shall be integrated in the PCU/inverter to maximize energy drawn from the array.

2.8. PCU/ Inverter As SPV arrays produce direct current electricity, it is necessary to convert this direct current into alternating current and adjust the voltage levels to match the grid voltage. Conversion shall be achieved using an electronic Inverter and the associated control and protection devices. All these components of the system are termed the "Power Conditioning Unit (PCU)". In addition, the PCU shall also house MPPT (Maximum Power Point Tracker), an interface between Solar PV array & the Inverter, to the power conditioning unit/inverter should also be DG set interactive, if necessary.

Inverter output should be compatible with the grid frequency. Typical technical features of the Inverter shall be as follows: However bidder can brought out in the technical bid for any deviations.

- Switching devices : IGBT/MOSFET
- Control : Microprocessor /DSP
- Nominal AC output voltage and frequency : 415V, 3 Phase, 50 Hz
(In case single phase inverters are offered, suitable arrangement for balancing the phases must be made.)
- Output frequency : 50 Hz
- Grid Frequency Synchronization range : + 3 Hz or more:
- Ambient temperature considered : -20oC to 50oC
- Humidity : 95 % Non-condensing
- Protection of Enclosure : IP-20 for indoor.
IP-65 for outdoor.



- Grid Frequency Tolerance range : + 3 or more
- Grid Voltage tolerance : - 20% & + 15 %
- No-load losses : Less than 1% of rated power
- Inverter efficiency(minimum) : >93% (In case of 10kW or above)
- Inverter efficiency (minimum) : > 97% (In case of less than 10 kW)
- THD : < 3%
- PF : > 0.9

a) Three phase PCU/ inverter shall be used with each power plant system (10kW and/or above) but in case of less than 10kW single phase inverter can be used.

b) PCU/inverter shall be capable of complete automatic operation including wake-up, synchronization & shutdown.

c) The output of power factor of PCU Inverter is suitable for all voltage ranges or sink of reactive power; Inverter should have internal protection arrangement against any sustainable fault in feeder line and against the lightning on feeder.

d) Built-in meter and data logger to monitor plant performance through external computer shall be provided.

e) The power conditioning units/Inverters should comply with applicable standards for efficiency measurements and environmental tests as per standard codes.

f) The charge controller (if any) / MPPT units environmental testing should qualify as per relevant standards. The junction boxes/ enclosures should be IP 65(for outdoor)/ IP 54 (indoor). g) The PCU/ Inverters should be tested from the MNRE approved test centers /NABL/BIS accredited testing- calibration laboratories. In case of imported power conditioning units, these should be approved by respective test houses.

2.9. Integration of PV Power with Grid The output power from SPV would be fed to the Inverters which converts DC produced by SPV array to AC and feeds it into the main electricity grid after synchronization. In case of grid failure, or low or high voltage, the solar PV system shall be out of synchronization and shall be disconnected from the grid. Once the DG set comes into service PV system shall again be synchronized with DG supply and load requirement would be met to the extent of availability of power. 4 pole isolation of inverter output with respect to the grid/ DG power connection needs to be provided.

2.10. Data Acquisition System / Plant Monitoring

a) Data Acquisition System shall be provided for the project.

b) Data Logging Provision for plant control and monitoring, time and date stamped system data logs for analysis with the high quality, suitable PC.



Metering and Instrumentation for display of systems parameters and status indication to be provided.

c) Solar Irradiance: An integrating Pyrometer / Solar cell based irradiation sensor (along with calibration certificate) provided, with the sensor mounted in the plane of the array. Readout integrated with the data logging system.

d) Temperature: Temperature probes for recording the Solar panel temperature and/or ambient temperature to be provided complete with readouts integrated with the data logging system

e) One set of data acquisition systems with data logging provision and weather monitoring system capturing the data as mentioned above, should be installed at a central location suggested by TIFR-Hyderabad serving as a central monitoring system and weather monitoring system for the projects commissioned by the bidder.

f) The following parameters are accessible via the operating interface display in real time separately for solar power plants:

i. AC Voltage.

ii. AC Output current.

iii. Output Power

iv. Power factor.

v. DC Input Voltage.

vi. DC Input Current.

vii. Time Active.

viii. Time disabled.

ix. Time Idle.

x. Power produced

xi. Protective function limits (Viz-AC Overvoltage, AC Under voltage, Over frequency, Under frequency ground fault, PV starting voltage, PV stopping voltage.

g) All major parameters available on the digital bus and logging facility for energy auditing through the internal microprocessor and read on the digital front panel at any time) and logging facility (the current values, previous values for up to a month and the average values) should be made available for energy auditing through the internal microprocessor and should be read on the digital front panel.

h) PV array energy production: Digital Energy Meters to log the actual value of AC/ DC voltage, current & energy generated by the PV system provided. Energy meter along with CT/PT should be of 0.5 accuracy class.

i) Computerized DC String/Array monitoring and AC output monitoring shall be provided as part of the inverter and/or string/array combiner box or separately.



- j) String and array DC Voltage, Current and Power, Inverter AC output voltage and current (All 3 phases and lines), AC power (Active, Reactive and Apparent), Power Factor and AC energy (All 3 phases and cumulative) and frequency shall be monitored.
 - k) Computerized AC energy monitoring shall be in addition to the digital AC energy meter.
 - l) The data shall be recorded in a common worksheet chronologically date wise. The data file shall be MS Excel compatible. The data shall be represented in both tabular and graphical form.
 - m) All instantaneous data shall be shown on the computer screen.
 - n) Software shall be provided for USB download and analysis of DC and AC parametric data for individual plants.
 - o) Provision for Internet monitoring and download of data shall be also incorporated.
 - p) Remote Server and Software for centralized Internet monitoring system shall be also provided for download and analysis of cumulative data of all the plants and the data of the solar radiation and temperature monitoring system.
 - q) Ambient / Solar PV module back surface temperature shall be also monitored on a continuous basis.
 - r) Simultaneous monitoring of DC and AC electrical voltage, current, power, energy and other data of the plant for correlation with solar and environment data shall be provided.
 - s) Remote Monitoring and data acquisition through Remote Monitoring System software at TIFR-Hyderabad location with latest software/hardware configuration and service connectivity for online / real time data monitoring/control complete to be supplied and operation and maintenance/control to be ensured by the supplier. Provision for interfacing these data on TIFR-Hyderabad server and portal in future shall be kept.
- 2.11. Power consumption Regarding the generated power consumption, priority needs to be given for internal consumption first and thereafter any excess power can be exported to the grid. Finalization of tariff is not under the purview of TIFR-Hyderabad. Decisions of appropriate authority/ state regulator may be followed.
- 2.12. Protections The system should be provided with all necessary protections like earthing, Lightning, and grid islanding as follows:
- 2.12.1. Lightning Protection The SPV power plants shall be provided with lightning & overvoltage protection. The main aim in this protection shall be to reduce the over voltage to a tolerable value before it reaches the PV or other sub system components.



The source of over voltage can be lightning, atmosphere disturbances etc. The entire space occupying the SPV array shall be suitably protected against Lightning by deploying the required number of Lightning Arrestors. Lightning protection should be provided as per the IS standard. The protection against induced high-voltages shall be provided by the use of metal oxide varistors (MOVs) and suitable earthing such that induced transients find an alternate route to earth.

2.12.2. Surge Protection Internal surge protection shall consist of three MOV type surge-arresters connected from +ve and -ve terminals to earth (via Y arrangement)

2.12.3. Earthing Protection

i. Each array structure of the PV yard should be grounded/ earthed properly as per IS:3043-1987. In addition, the lightning arrester/masts should also be earthed inside the array field. Earth Resistance shall be tested in presence of the representative of TIFR-Hyderabad as and when required after earthing by calibrated earth tester. PCU, ACDB and DCDB should also be earthed properly.

ii. Earth resistance shall not be more than 5 ohms. It shall be ensured that all the earthing points are bonded together to make them at the same potential.

2.12.4. Grid Islanding

2.12.5. i. In the event of a power failure on the electric grid, it is required that any independent power-producing inverters attached to the grid turn off in a short period of time. This prevents the DC-to-AC inverters from continuing to feed power into small sections of the grid, known as "islands." Powered islands present a risk to workers who may expect the area to be unpowered, and they may also damage grid-tied equipment. The Rooftop PV system shall be equipped with islanding protection. In addition to disconnection from the grid (due to islanding protection) disconnection due to under and over voltage conditions shall also be provided.

A manual disconnect 4 pole isolation switch beside automatic disconnection to grid would have to be provided at utility end to isolate the grid connection by the utility personnel to carry out any maintenance. This switch shall be locked by the utility personnel.

2.13. Cables

Cables of appropriate size to be used in the system shall have the following characteristics:

i. Shall meet relevant standards.

ii. Temp. Range: +10°C to +80°C.

iii. Voltage rating 660/1000V

iv. Excellent resistance to heat, cold, water, oil, abrasion, UV radiation, flexible



- v. Sizes of cables between array interconnections, array to junction boxes, junction boxes to Inverter, etc. shall be so selected to keep the voltage drop (power loss) of the entire solar system to the minimum. The cables (as per IS) should be insulated with a special grade PVC compound formulated for outdoor use.
- vi. Cable Routing/ Marking: All cable/wires are to be routed in a GI cable tray and suitably tagged and marked with proper manner by good quality ferrule or by other means so that the cable is easily identified.
- vii. The Cable should be so selected that it should be compatible up to the life of the solar PV panels i.e. 25 years.
- viii. The ratings given are approximate. Bidder to indicate size and length as per system design requirement. All the cables required for the plant were provided by the bidder. Any change in cabling sizes if desired by the bidder/approved after citing appropriate reasons. All cable schedules/layout drawings approved prior to installation.
- ix. Multi Strand, annealed high conductivity copper conductor PVC type 'A' pressure extruded insulation or XLPE insulation. Overall PVC/XLPE insulation for UV protection Armored cable for underground laying. All cable trays including covers to be provided. All cables conform to the latest edition BIS Standards.
- x. The size of each type of DC cable selected shall be based on minimum voltage drop however; the maximum drop shall be limited to 1%.
- xi. The size of each type of AC cable selected shall be based on minimum voltage drop however; the maximum drop shall be limited to 2%.

2.14. Tools & Tackles and Spares

a) After completion of installation & commissioning of the power plant, necessary tools & tackles are to be provided free of cost by the bidder for maintenance purposes. List of tools and tackles to be supplied by the bidder for approval of specifications and make from TIFR-Hyderabad.

b) A list of requisite spares in case of PCU/inverter comprising of a set of control logic cards, IGBT driver cards etc. Junction Boxes. Fuses, MOVs / arrestors, MCCBs etc along with a spare set of PV modules are indicated, which shall be supplied along with the equipment. A minimum set of spares shall be maintained in the plant itself for the entire period of contract and Operation & Maintenance which upon its use shall be replenished.

2.15. Danger Boards and Signages

Danger boards should be provided as and where necessary as per IE Act. /IE rules as amended up to date. The text of the signage may be finalized in consultation with TIFR-Hyderabad.

2.16. Fire Extinguishers



The fire fighting system for the proposed power plant for fire protection shall be consisting of:

- a) Portable fire extinguishers in the control room for fire caused by electrical short circuits.
- b) Sand buckets in the control room.
- c) The installation of Fire Extinguishers should confirm to TAC regulations and BIS standards. The fire extinguishers shall be provided in the control room housing PCUs as well as on the Roof or site where the PV arrays have been installed.

2.17. Drawings & Manuals

Two sets of Engineering, electrical drawings and Installation and O&M manuals are to be supplied. Bidders shall provide complete technical data sheets for each equipment giving details of the specifications along with make/makes in their bid along with basic design of the power plant and power evacuation, synchronization along with protection equipment.

- a. Approved ISI and reputed makes for equipment be used.
- b. For complete electro-mechanical works, bidders shall supply complete design, details and drawings for approval to TIFR-Hyderabad before progressing with the installation work.

2.18. Planning and Designing

a. The bidder should carry out Shadow Analysis at the site and accordingly design strings & arrays layout considering optimal usage of space, material and labor. The bidder should submit the array layout drawings along with Shadow Analysis Report to TIFR, Hyderabad for approval.

b. TIFR-Hyderabad reserves the right to modify the landscaping design, Layout and specification of sub-systems and components at any stage as per local site conditions/requirements.

c. The bidder shall submit preliminary drawing for approval & based on any modification or recommendation, if any. The bidder submits three sets and soft copy in CD of final drawing for formal approval to proceed with construction work.

2.19. Drawings to be Furnished by Bidder after Award of Contract

a) The Contractor shall furnish the following drawings Award/Intent and obtain approval.

b) General arrangement and dimensioned layout.

c) Schematic drawing showing the requirement of SV panel, Power conditioning Unit(s)/ inverter, Junction Boxes, AC and DC Distribution Boards, meters etc.



- d) Structural drawing along with foundation details for the structure.
- e) Itemized bill of material for complete SV plant covering all the components and associated accessories.
- f) Layout of solar Power Array.
- g) Shadow analysis of the roof.

2.20. Solar PV System on the Rooftop for Meeting the Annual Energy Requirement

a) The Solar PV system on the rooftop of the selected buildings will be installed for meeting up to 90% of the annual energy requirements depending upon the area of rooftop available and the remaining energy requirement of the office buildings will be met by drawing power from the grid at commercial tariff of DISCOMs.

b) All the equipment, such as solar panels, inverters, batteries, DC DB and AC DB, DC cables, AC cables, etc. used in the plant shall be approved by the MNRE/SECI. The statutory test and inspection by CEA shall be arranged by the contractor at his cost and risk.

2.21. Maintenance of Solar PV system.

a) All necessary Preventive maintenance to be carried out as per the maintenance schedules of the system.

b) Successful bidder shall tap the water from the nearest existing plumbing line for cleaning the solar PV cells.

2.22. Safety Measures The bidder shall take entire responsibility for electrical safety of the installation(s) including connectivity with the grid and follow all the safety rules & regulations applicable as per Electricity.



SECTION-III

INFORMATION AND INSTRUCTIONS FOR BIDDERS

1. GENERAL:
 - 1.1. All information called for in the enclosed forms should be furnished against the relevant columns in the forms. If for any reason, information is furnished on a separate sheet, this fact should be mentioned against the relevant column. Even if no information is to be provided in a column, a "nil" or "no such case" entry should be made in that column. If any particulars/query is not applicable in case of the bidder, it should be stated as "not applicable". The bidders are cautioned that not giving complete information called for in the application forms or not giving it in clear terms or making any change in the prescribed forms or deliberately suppressing the information may result in the bid being summarily disqualified.
 - 1.2. The bid should be type-written. The bidder should sign each page of the application.
 - 1.3. Overwriting should be avoided. Correction, if any, should be made by neatly crossing out, initialing, dating and rewriting, pages of the bid document are numbered. Additional sheets, if any added by the contractor, should also be numbered by him. They should be submitted as a package with a signed letter of transmittal.
 - 1.4. References, information and certificates from the respective clients certifying suitability, technical knowledge or capability of the bidder should be signed by an officer not below the rank of Executive Engineer or equivalent
 - 1.5. The bidder may furnish any additional information which he thinks is necessary to establish his capabilities to successfully complete the envisaged work. He is, however, advised not to furnish superfluous information. No information shall be entertained after uploading of eligibility criteria document unless it is called for by the Engineer in-Charge.
2. METHOD OF APPLICATION:

If the bidder is an individual, the application shall be signed by him above his full typewritten name and current address.

 - 2.1. If the bidder is a proprietary firm, the application shall be signed by the proprietor above his full typewritten name and the full name of his firm with its current address.
 - 2.2. If the bidder is a firm in partnership, the application shall be signed by all the partners of the firm above their full typewritten names and current address, or, alternatively, by a partner holding power of attorney for the firm. In the later case a certified copy of the power of attorney should accompany the application. In both cases a certified copy of the partnership deed and current address of all the partners of the firm should accompany the application.
 - 2.3. If the bidder is a limited company or a corporation, the application shall be signed by a duly authorized person holding power of attorney for signing the application accompanied by a



copy of the power of attorney. The bidder should also furnish a copy of the Memorandum of Articles of Association duly attested by a Public Notary.

3. DELIVERY OF SOLAR POWER:

TIFR-Hyderabad will purchase one hundred percent (100%) of the Solar Power generated by the solar roof-top system at the delivery point during each relevant month. If TIFR-Hyderabad is unable to take 100% of the electricity generated, then Deemed Generation will apply as per the standard procedure at mutually agreeable conditions. Deemed generation is not applicable if 100% or part of the rooftop solar system is at faulty or not working.

4. TARIFF AND PAYMENTS:

- 4.1. TIFR-Hyderabad will pay to the Solar Power Producer on a monthly basis for the Solar Power generated by the system during the particular month.
- 4.2. The Power producer shall invoice TIFR, Hyderabad on monthly basis on a particular date of each month after commencing the commercial operation. The invoice to TIFR, Hyderabad shall include the following.
 - a) The Solar power calculations for the relevant billing period.
 - b) Supporting data, documents and calculations in accordance with the PPA.
- 4.3. In case 100% or part of the rooftop solar system is faulty, the power producer has to pay TIFR-Hyderabad for the deemed generation as per the prevailing tariff of TSSPDCL.

5. PROJECT COST ON A YEAR-ON-YEAR DEPRECIATION BASIS:

The Power Producer and TIFR-Hyderabad shall enter the purchase value of the system over a period of 25 years in the PPA. This may be applicable in case TIFR-Hyderabad wishes to own the project before the tenure of the PPA. The price reference shall be taken for calculating the total cost of the system as per the CERC (Central Electricity Regulatory Commission) guidelines for arriving at the system cost on a year-on-year depreciation basis for total PPA tenure of 25 years.

6. FINAL DECISION-MAKING AUTHORITY

The employer reserves the right to accept or reject any bid and to annul the process and reject all bids at any time without assigning any reason thereof or incurring any liability to the bidders.

7. PARTICULARS PROVISIONAL

The particulars of the work given in Section I are provisional. They are liable to change and must be considered only as advance information to assist the bidders.

8. SITE VISIT



टाटा मूलभूत अनुसंधान संस्थान
TATA INSTITUTE OF FUNDAMENTAL RESEARCH
भारत सरकार के परमाणु ऊर्जा विभाग की स्वायत्त संस्था एवं समविश्वविद्यालय
(Autonomous Institution of the Department of Atomic Energy, Government of India)
सर्वेक्षण संख्या 36 / पी, गोपनपल्ली गांव, सेरिलिंगमपल्ली मंडल, रंगारेड्डी जिला, हैदराबाद - 500 046
Survey No.36/P, Gopanpally Village, Serilingampally Mandal, Ranga Reddy District,
Hyderabad-500046, Telangana

The bidder is advised to visit the site of work, at his own cost, and examine it and its surroundings to satisfy himself and collect all information that he considers necessary for proper assessment of the prospective assignment. Site Survey Plan is available with Engineering Unit at TIFR-Hyderabad if required. The Bidder shall not be entitled to hold any claim against Employer/ Owner for non compliance due to lack of any kind of pre-requisite information as it is the sole responsibility of the Bidder to obtain all the necessary information with regard to site, surrounding, working conditions, weather etc. on its own before submission of the bid.

9. OPENING OF THE FINANCIAL BID

The price bid will be opened for technically qualified bidders Only. The bids shall remain valid for 75 days from the date of opening of the Technical Bids.

10. AWARD CRITERIA

The employer reserves the right, without being liable for any damages or obligation to inform the bidder, to:

- (a) Amend the scope and value of the contract to the bidder.
- (b) Reject any or all of the applications without assigning any reason.

Any effort on the part of the bidder or his agent to exercise influence or to pressurize the employer would result in the rejection of his bid. Canvassing of any kind is prohibited.

11. GENERAL RULES & DIRECTIONS

Officer inviting tender: Head, Engineering Unit, TIFR-Hyderabad.

Definitions:

	Engineer-in-Charge	Engineer-E, Engineering Unit, TIFR-Hyderabad or successor thereof. for Electrical
	Accepting Authority	Head-Infrastructure, TIFR-Hyderabad

Authority to decide:

	Extension of time	Engineer-E, Engineering Unit, TIFR-Hyderabad or successor thereof. for Electrical
	Rescheduling of milestones	Head-Infrastructure, TIFR-Hyderabad



टाटा मूलभूत अनुसंधान संस्थान
TATA INSTITUTE OF FUNDAMENTAL RESEARCH
भारत सरकार के परमाणु ऊर्जा विभाग की स्वायत्त संस्था एवं समविश्वविद्यालय
(Autonomous Institution of the Department of Atomic Energy, Government of India)
सर्वेक्षण संख्या 36 / पी, गोपनपल्ली गांव, सेरिलिंगमपल्ली मंडल, रंगारेड्डी जिला, हैदराबाद - 500 046
Survey No.36/P, Gopanpally Village, Serilingampally Mandal, Ranga Reddy District,
Hyderabad-500046, Telangana

	Shifting of date of start in case of delay in handing over of site	Head-Infrastructure, TIFR-Hyderabad
--	--	-------------------------------------

12. Liquidated Damages for Delay in Project Implementation

The Bidder shall complete the project identification, Site Survey, Design, Engineering, Supply, Storage, Civil Works, Installation, Testing and Commissioning of the entire project within 120 days from the date of issue of LoA.

If the bidder fails to commission the allocated capacity within 120 days from date of issue of LoA, the liquidated damage as per day per kWp basis for the delayed period would be levied from the Performance Security up to a period of 6 months from the SCD (Schedule Commissioning date) as per following example:

Example: In case a project of 500 kWp capacity, if commissioning of 200 kWp capacity is delayed by 25 days from scheduled date, then LD shall be as follows:

Sl. No	Commissioned capacity as on Scheduled Commissioning date (SCD)	Capacity remaining un-commissioned as on SCD	Date of completion of respective portions	Delay from SCD (in days)
1	300kWp	200kWp	Commissioning date	0
2	200kWp	0	Commissioning date+25	

i) Amount of Performance Security = Say 10,00,000

ii) Proposed capacity = 500 kWp

iii) Perf. Security per kWp per day for 6 months = $10,00,000/500/180$

= Rs 11.11/- per day per kWp

iv) LD calculation: -

In case of above commissioning schedule, for 300kWp capacity commissioned within SCD (Scenario 1) there will be no LD.

For balance 200kWp capacity for a delay of 25 days from SCD (Scenario 2), the LD calculation for encashment of Perf. Security, shall be done as follows:



टाटा मूलभूत अनुसंधान संस्थान
TATA INSTITUTE OF FUNDAMENTAL RESEARCH
भारत सरकार के परमाणु ऊर्जा विभाग की स्वायत्त संस्था एवं समविश्वविद्यालय
(Autonomous Institution of the Department of Atomic Energy, Government of India)
सर्वेक्षण संख्या 36 / पी, गोपनपल्ली गांव, सेरिलिंगमपल्ली मंडल, रंगारेड्डी जिला, हैदराबाद - 500 046
Survey No.36/P, Gopanpally Village, Serilingampally Mandal, Ranga Reddy District,
Hyderabad-500046, Telangana

Total LD= (200kWp x25x INR 11.11) = INR 55,555/- After the expiry of 6 months from SCD allocated capacity will get canceled and 100% of Performance Security will be forfeited excluding for the completed capacity on a proportionate basis.

14. Transfer of Plant After completion of 25 years from the date of commercial operation, the entire plant/assets of 500kWp RoofTop Solar PV System to be transferred to TIFR-Hyderabad at free of cost.



टाटा मूलभूत अनुसंधान संस्थान
TATA INSTITUTE OF FUNDAMENTAL RESEARCH
भारत सरकार के परमाणु ऊर्जा विभाग की स्वायत्त संस्था एवं समविश्वविद्यालय
(Autonomous Institution of the Department of Atomic Energy, Government of India)
सर्वेक्षण संख्या 36 / पी, गोपनपल्ली गांव, सेरिलिंगमपल्ली मंडल, रंगारेड्डी जिला, हैदराबाद - 500 046
Survey No.36/P, Gopanpally Village, Serilingampally Mandal, Ranga Reddy District,
Hyderabad-500046, Telangana

SECTION-IV

ANNEXURES

Annexure-I

DETAILS OF ELIGIBLE SIMILAR NATURE OF WORKS SUCCESSFULLY COMPLETED DURING THE LAST FIVE YEARS ENDING PREVIOUS DAY OF LAST DATE OF SUBMISSION OF TENDERS

Sl. No	Name of Work/Project & Location	Owners Complete address with tele. No with contact person	Value of Contract in Rs.	Duration of Contract			Details of Work including Major items of work involved	Ref. Date of letter Intent of & Completion certificate enclosed
				Commencement date	Scheduled Completion date	Actual Completion Date		
1	2	3	4	5	6	7	8	9

Signature of Tenderer

Note: The project should be completed and the system should be in operational conditions only to be considered for technical evaluation.



Annexure-II

PERFORMANCE REPORT OF WORKS REFERRED IN ANNEXURE-I

1.		Name of work / Project & Location	
2.		Agreement No.	
3.		Tendered Capacity (in kWp)	
4.		Installed Capacity (in kWp)	
5.		Date of Start	
6.		Date of completion	
	a)	Stipulated Date of Completion (as mentioned in work order)	
	b)	Actual Date of Completion	
7.		Date of Commissioning	
8.		Amount of compensation levied for delayed completion if any	
	a)	Whether case of levy of compensation for the delay has been decided or not	Yes/No
	b)	If decided, amount of compensation levied for delayed completion, if any	
9.		Amount of reduced rate items, if any	
	a)	Performance Report	
	b)	Quality of Work	Outstanding/Very Good/Good/Poor
	c)	Financial Soundness	Outstanding/Very Good/Good/Poor
	d)	Technical Proficiency	Outstanding/Very Good/Good/Poor
	e)	Resourcefulness	Outstanding/Very Good/Good/Poor
	e)	General behavior	Outstanding/Very Good/Good/Poor
10.		Remarks (if any):	
		Note: (TDS to be submitted in case of non-Governmental works were executed).	

Dated:

Executive Engineer Or Equivalent with stamp



Annexure-III

PROFORMA OF AFFIDAVIT FOR NON-BLACK LISTING

I/we undertake and confirm that our firm/partnership firm has not been blacklisted by any state/Central Departments/PSUs/Autonomous bodies during the last 5 years of its operations. Further that, if such information comes to the notice of the department then I/we shall be debarred for bidding in TIFR-Hyderabad in future forever. Also, if such information comes to the notice of department on any day before date of start of work, the Engineer-in-charge shall be free to cancel the agreement and to forfeit the entire amount of Earnest Money Deposit/Performance Guarantee (Scanned copy of this notarized affidavit to be uploaded at the time of submission of bid)

Signature of Bidder(s) or an authorized
Officer of the firm with stamp

Signature of Notary with seal

Note:- 1.

The affidavit shall be made on the current date after the date of invitation of the Tender otherwise the tender shall be rejected.

Affidavit shall be furnished on a 'Non-Judicial' stamp paper worth Rs.100/- otherwise the tender shall be rejected



Annexure-IV

FINANCIAL INFORMATION

Name of the firm / contractor.....:

I. Financial Analysis-Details to be furnished duly supported by figures in balance sheet/ profit & loss account for the last five financial years duly certified and audited by the Chartered Accountants, as submitted by the applicant to the Income Tax Department (Copies to be attached).

Sl. No	Particulars	Financial Year (Fig. in Lakhs Rs.)				
		2018-19	2019-20	2020-21	2021-22	2022-23
1	Gross Annual turnover on construction works					
2	Profit / Loss					

Financial arrangements for carrying out the proposed work.

SIGNATURE OF BIDDER(S)

Signature of Chartered Accountant with Seal



टाटा मूलभूत अनुसंधान संस्थान
TATA INSTITUTE OF FUNDAMENTAL RESEARCH
भारत सरकार के परमाणु ऊर्जा विभाग की स्वायत्त संस्था एवं समविश्वविद्यालय
(Autonomous Institution of the Department of Atomic Energy, Government of India)
सर्वेक्षण संख्या 36 / पी, गोपनपल्ली गांव, सेरिलिंगमपल्ली मंडल, रंगारेड्डी जिला, हैदराबाद - 500 046
Survey No.36/P, Gopanpally Village, Serilingampally Mandal, Ranga Reddy District,
Hyderabad-500046, Telangana

Annexure -V

UNDERTAKING REGARDING NON-FILING OF GST RETURN

To
The Head-Technical Services
TIFR-Hyderabad,

Name of Work: -

Setting up for “500 KWp Grid-connected Rooftop Grid Connected Solar PV Power Plant under RESCO mode” at TIFR, Survey No. 36/P, Gopanpally (Village), Serilingampally (Mandal), Ranga Reddy Dist., Hyderabad-500046 including Operation & Maintenance (O & M) of the project for a period of 25 (Twenty-five) years after operational acceptance”.

Sir,

Having examined the details given in bid document for the above work, I/we hereby submit the following:

“I/we hereby certify that I/we have not filed any GST return”.

Seal of bidder:

Date of submission:

Signature(s) of Bidder(s)



Annexure-VI

DECLARATION ABOUT SITE INSPECTION

To
The Head-Technical Services
TIFR-Hyderabad,

Name of Work: -

Setting up for “500 KWp Grid-connected Rooftop Grid Connected Solar PV Power Plant under RESCO mode” at TIFR, Survey No. 36/P, Gopanpally (Village), Serilingampally (Mandal), Ranga Reddy Dist., Hyderabad-500046 including Operation & Maintenance (O & M) of the project for a period of 25 (Twenty-five) years after operational acceptance”.

Dear Sir,

It is hereby declared, I/ We the bidder inspected and examined the subject site and its surroundings and satisfied myself/ourselves as to the forms and nature of the site. / ourselves before submitting the bid, the accommodation which may require and all necessary information as to risks, contingencies and other circumstances which may influence or affect our bid have been obtained. I/We the bidder shall have full knowledge of the site and no extra charge consequent upon any misunderstanding or otherwise shall be claimed at a later date.

I /We bidder shall be responsible for arranging and maintaining at own cost all materials, tools & plants, water, electricity access, facilities for workers and all other services required for executing the work unless otherwise specifically provided for in the contract documents. Submission of a bid by me/us implies that I / We have read this notice and all other contract documents and has made myself /ourselves aware of the scope and specifications of the work to be done and local conditions and other factors having a bearing on the execution of the work.

Yours faithfully

(Duly authorized signatory of the bidder)



Annexure-VII

Undertaking Regarding GST Registration in The State of Telangana.

To
The Head-Technical Services
TIFR-Hyderabad,

Name of Work: -

Setting up for “500 KWp Grid-connected Rooftop Grid Connected Solar PV Power Plant under RESCO mode” at TIFR, Survey No. 36/P, Gopanpally (Village), Serilingampally (Mandal), Ranga Reddy Dist., Hyderabad-500046 including Operation & Maintenance (O & M) of the project for a period of 25 (Twenty-five) years after operational acceptance”.

Sir,

Having examined the details given bid document for the above work, I/we hereby submit the following:

"If work is awarded to me/us, I/we shall obtain GST registration certificate in the state of Telangana within one month from date of receipt of award letter or before release of any payment by TIFR-Hyderabad, whichever is earlier, failing which I/We shall be responsible for any delay in payment which will be due towards me/us on account of work executed and/or for any action taken by TIFR-Hyderabad or GST department in this regard."

Seal of bidder:

Date of submission:

Signature(s) of Bidder(s)



Annexure-VIII

STRUCTURE & ORGANISATION

1.	Name & Address of the bidder	
2.	Telephone No. /Email id /Telex No./Fax No.	
3.	Legal status of the bidder (Scan and Upload copies of original document defining the legal status).	
a)	An Individual	
b)	A proprietary firm	
c)	A firm in partnership	
d)	A limited company or Corporation	
4.	Particulars of registration with various Government bodies (Scan and Upload attested photo-copy).	
	ORGANIZATION/PLACE OF REGISTRATION	REGISTRATION NO.
a)		
b)		
c)		
5.	Names and Titles of Directors & Officers with a designation to be concerned with this work.	
6.	Designation of individuals authorized to act for the organization.	
7.	Has the bidder, or any constituent partner in case of partnership firm Limited company/ Joint Venture, ever been convicted by the court of law? If so, give details.	
9.	Any other information considered necessary but not included above.	

SIGNATURE OF THE BIDDER



टाटा मूलभूत अनुसंधान संस्थान
TATA INSTITUTE OF FUNDAMENTAL RESEARCH
भारत सरकार के परमाणु ऊर्जा विभाग की स्वायत्त संस्था एवं समविश्वविद्यालय
(Autonomous Institution of the Department of Atomic Energy, Government of India)
सर्वेक्षण संख्या 36 / पी, गोपनपल्ली गांव, सेरिलिंगमपल्ली मंडल, रंगारेड्डी जिला, हैदराबाद - 500 046
Survey No.36/P, Gopanpally Village, Serilingampally Mandal, Ranga Reddy District,
Hyderabad-500046, Telangana

Annexure-IX

DETAILS OF PROPOSED APPROACH & METHODOLOGY

Bidder shall furnish a detailed method statement (Technical Note) for carrying out of the works, along with a construction programme [Preferably in MS project / Primavera] showing sequence of operation and the time frame for various segments of temporary and permanent works.

Signature (Authorized Signatory)



Annexure-X

INTEGRITY PACT

To,

.....,
.....,
.....

Sub: NIT No.: **TIFR/PD/CF24-17/240087** for Site Survey, Design, Engineering, Supply, Storage, Civil Works, Installation, Testing and Commissioning of solar PV Project of capacity 500 kWp on the rooftop of various academic buildings of TIFR-Hyderabad, including Operation & Maintenance (O & M) of the system for a period of 25 years under RESCO model after operational acceptance.

Dear Sir,

It is hereby declared that TIFR-Hyderabad is committed to follow the principle of transparency, equity and competitiveness in public procurement. The subject Notice Inviting Tender (NIT) is an invitation to offer made on the condition that the Bidder will sign the integrity Agreement, which is an integral part of tender/bid documents, failing which the tenderer/bidder will stand disqualified from the tendering process and the bid of the bidder would be summarily rejected.

This declaration shall form part and parcel of the Integrity Agreement and signing of the same shall be deemed as acceptance and signing of the Integrity Agreement on behalf of the TIFR-Hyderabad.

Yours faithfully



Annexure-XI

INTEGRITY AGREEMENT

To
The Head-Technical Services
TIFR-Hyderabad,

Name of Work: -

Setting up for “500 KWp Grid-connected Rooftop Grid Connected Solar PV Power Plant under RESCO mode” at TIFR, Survey No. 36/P, Gopanpally (Village), Serilingampally (Mandal), Ranga Reddy Dist., Hyderabad-500046 including Operation & Maintenance (O & M) of the project for a period of 25 (Twenty-five) years after operational acceptance”.

Dear Sir,

I/We acknowledge that TIFR-Hyderabad is committed to follow the principles thereof as enumerated in the Integrity Agreement enclosed with the tender/bid document.

I/We agree that the Notice Inviting Tender (NIT) is an invitation to offer made on the condition that I/We will sign the enclosed integrity Agreement, which is an integral part of tender documents, failing which I/We will stand disqualified from the tendering process. I/We acknowledge that **THE MAKING OF THE BID SHALL BE REGARDED AS AN UNCONDITIONAL AND ABSOLUTE ACCEPTANCE** of this condition of the NIT.

I/We confirm acceptance and compliance with the Integrity Agreement in letter and spirit and further agree that execution of the said Integrity Agreement shall be separate and distinct from the main contract, which will come into existence when tender/bid is finally accepted by TIFR-Hyderabad. I/We acknowledge and accept the duration of the Integrity Agreement, which shall be in the line with Article 1 of the enclosed Integrity Agreement.

I/We acknowledge that in the event of my/our failure to sign and accept the Integrity Agreement, while submitting the tender/bid, TIFR-Hyderabad shall have unqualified, absolute and unfettered right to disqualify the tenderer/bidder and reject the tender/bid in accordance with terms and conditions of the tender/bid.

Yours faithfully

(Duly authorized signatory of the Bidder)

To be signed by the bidder and same signatory competent / authorized to sign the relevant contract on behalf of TIFR-Hyderabad



Annexure-XII

LETTER OF SUBMISSION- COVERING LETTER

(The covering letter should be on the Letterhead of the Bidder and is to be submitted in Envelope 1)

Tel:-

Email address:-

To

The Head-Technical Services

TIFR-Hyderabad,

Name of Work: -

Setting up for “500 KWp Grid-connected Rooftop Grid Connected Solar PV Power Plant under RESCO mode” at TIFR, Survey No. 36/P, Gopanpally (Village), Serilingampally (Mandal), Ranga Reddy Dist., Hyderabad-500046 including Operation & Maintenance (O & M) of the project for a period of 25 (Twenty-five) years after operational acceptance”.

Dear Sir,

I/We, the undersigned, [“insert name of the bidder”] having read, examined and understood in detail the Tender Document for **Setting up for “500 KWp Grid-connected Rooftop Grid Connected Solar PV Power Plant under RESCO mode” at TIFR, Survey No. 36/P, Gopanpally (Village), Serilingampally (Mandal), Ranga Reddy Dist., Hyderabad-500046 including Operation & Maintenance (O & M) of the project for a period of 25 (Twenty-five) years after operational acceptance”.** (the “Tender Document”) in India hereby submit our Proposal comprising of a General Qualification submission, technical proposal, and financial proposal (“Price Bid”). We confirm that neither we nor any of our Parent Company / Affiliate/Ultimate Parent Company has submitted a Bid other than this Bid directly or indirectly in response to the aforesaid Tender Document.

We give our unconditional acceptance to the tender dated and documents attached thereto, issued by TIFR-Hyderabad, as may have been amended from time to time. As a token of our acceptance of the Tender Document, the same have been initiated by us and enclosed to the Bid. We shall ensure that we execute relevant Tender Documents as per the provisions of the Tender Document and the provisions of such Tender Document shall be binding on us.

Bid Capacity



टाटा मूलभूत अनुसंधान संस्थान
TATA INSTITUTE OF FUNDAMENTAL RESEARCH
भारत सरकार के परमाणु ऊर्जा विभाग की स्वायत्त संस्था एवं समविश्वविद्यालय
(Autonomous Institution of the Department of Atomic Energy, Government of India)
सर्वेक्षण संख्या 36 / पी, गोपनपल्ली गांव, सेरिलिंगमपल्ली मंडल, रंगारेड्डी जिला, हैदराबाद - 500 046
Survey No.36/P, Gopanpally Village, Serilingampally Mandal, Ranga Reddy District,
Hyderabad-500046, Telangana

We have bid for the following capacities in various buildings as specified in this Tender Document and have accordingly submitted our Price Bids for the same:

Sl. No	Locations / Sites	Generation Capacity (kWp)*
1	Main Building	60
2	Service Building-1	56
3	Service Building-2	36
4	Hostel-1	50
5	Hostel-2	80
6	Hostel-3	68
7	Hanger-1	39
8	Hanger-2	45
9	Petawatt	90
10	Car Parking	45
	Total in kWp	569

Note:

Bidder to input the actual generation capacity arrived by his own evaluation of the site in the above column. Drawings indicate the layout of PV panels along with structure should be enclosed along with the technical bid for evaluation.

2. Acceptance

We hereby unconditionally and irrevocably agree and accept that the decision made by TIFR-Hyderabad in respect of any matter regarding or arising out of the Tender Document binding on us.

We hereby expressly waive any and all claims in respect of the Bid process. We confirm that there are no litigations or disputes against us, which may materially affect our ability to fulfill our obligations with regard to the execution of projects of the capacity offered by us.

3. Familiarity with Relevant Indian Laws & Regulations



टाटा मूलभूत अनुसंधान संस्थान
TATA INSTITUTE OF FUNDAMENTAL RESEARCH
भारत सरकार के परमाणु ऊर्जा विभाग की स्वायत्त संस्था एवं समविश्वविद्यालय
(Autonomous Institution of the Department of Atomic Energy, Government of India)
सर्वेक्षण संख्या 36 / पी, गोपनपल्ली गांव, सेरिलिंगमपल्ली मंडल, रंगारेड्डी जिला, हैदराबाद - 500 046
Survey No.36/P, Gopanpally Village, Serilingampally Mandal, Ranga Reddy District,
Hyderabad-500046, Telangana

We confirm that we have studied the provisions of the relevant Indian laws and regulations as required to enable us to submit this Bid and execute the Tender Document documents as appropriate and implement the projects as bid for by us, in the event of our selection as Successful Bidder. We further undertake and agree that all relevant factors as mentioned in the Tender Document have been fully examined and considered while submitting the Bid.

Contact Person

Name	
Designation	
Company	
Address	
Phone Nos.	
Fax Nos.	
E-mail address	

We are enclosing herewith Envelope 1 (General Qualification Submission & Technical Proposal) and Envelope 2 (Price Bid) containing duly signed formats, each one duly sealed separately, in one original and one copy as desired by you in the Tender Document consideration.

It is confirmed that our Bid is consistent with all the requirements of submission as stated in the Tender and subsequent communications from TIFR-Hyderabad. The information submitted in our Bid is complete, strictly as per the requirements stipulated in the Tender Document and is correct to the best of our knowledge and understanding. We shall be solely responsible for any errors or omissions in our Bid. We confirm that all the terms and conditions of our Bid are valid for acceptance for a period of Seventy Five (75) days from the Bid Submission Date. We confirm that there is no deviation in our Bid from the requirements of the Tender Document as may result in it being deemed non-responsive.

Date:

Thanking you,

Yours Faithfully,

Name, Designation and Signature of Authorized Person in whose name Power of Attorney / Board Resolution has been issued by the Bidder.



Annexure-XIII

Modified form for Bank Guarantee for Performance Guarantee / Security Deposit

1. Whereas the Registrar, TIFR-Hyderabad, on behalf of TIFR-Hyderabad (hereinafter called "The TIFR-Hyderabad") has invited bids under (NIT Number) dated for (Name of work)..... (hereinafter called "the contractor") for compliance of his obligations in accordance with the terms and conditions of the said NIT.
** or **

Whereas the **Head, Engineering Unit, TIFR-Hyderabad** (name of Institute), on behalf of TIFR-Hyderabad (hereinafter called "The TIFR-Hyderabad") as entered into an agreement bearing number With (name and address of the contractor) (hereinafter called "the Contractor") for execution of work (name of work) TIFR-Hyderabad has further agreed to accept an irrevocable Bank Guarantee for Rs. (Rupees only) valid upto (date) As **Performance Guarantee / Security Deposit / Mobilization Advance** from the said Contractor for compliance of his obligations in accordance with the terms and conditions of the agreement.

2. We, (indicate the name of the bank) (hereinafter referred to as "the Bank"), hereby undertake to pay to the TIFR-Hyderabad an amount not exceeding Rs. (Rupees Only) on demand by the TIFR-Hyderabad within 10 days of the demand.

3. We, (indicate the name of the Bank), do here by undertake to pay the amount due and payable under this guarantee without any demur, merely on a demand from the TIFR-Hyderabad stating that the amount claimed is required to meet the recoveries due or likely to be due from the said amount due from the said Contractor. Any such demand made on the Bank shall be conclusive as regards the amount due and payable by the Bank under this Guarantee. However, our liability under this guarantee shall be restricted to an amount not exceeding Rs. (Rupees only).

4. We, (indicate the name of the Bank), further undertake to pay the TIFR-Hyderabad any money so demanded notwithstanding any dispute or dispute raised by the contractor in any suit or proceeding pending before any Court or Tribunal, our liability under this Bank Guarantee being absolute and unequivocal. The payment so made by us under this Bank Guarantee shall be valid discharge of our liability for payment there under and the Contractor shall have no claim against us for making such payment

5. We, (indicate the name of the Bank), further agree that the TIFR-Hyderabad shall have the fullest liberty without our consent and without affecting any manner our obligation here under to vary any of the terms and conditions of the said agreement or to extend time of performance by the said Contractor from time to time or to postpone for any time or from time to time any of the powers exercisable by the TIFR-Hyderabad against the said contractor and to forbear or enforce any of the terms and conditions relating to the said agreement and we shall not be relieved from our liability by reason of any such variation or extension being granted to the said Contractor or for any forbearance, act of omission on the part of the TIFR-Hyderabad or any



टाटा मूलभूत अनुसंधान संस्थान
TATA INSTITUTE OF FUNDAMENTAL RESEARCH
भारत सरकार के परमाणु ऊर्जा विभाग की स्वायत्त संस्था एवं समविश्वविद्यालय
(Autonomous Institution of the Department of Atomic Energy, Government of India)
सर्वेक्षण संख्या 36 / पी, गोपनपल्ली गांव, सेरिलिंगमपल्ली मंडल, रंगारेड्डी जिला, हैदराबाद - 500 046
Survey No.36/P, Gopanpally Village, Serilingampally Mandal, Ranga Reddy District,
Hyderabad-500046, Telangana

indulgence by the TIFR-Hyderabad to the said Contractor or by any such matter or thing whatsoever which under the law relating to sureties would, but for this provision, have effect of so relieving us.

6. We, (indicate the name of the Bank), further agree that the TIFR-Hyderabad at its option shall be entitled to enforce this Guarantee against the Bank as a principal debater at the first instance without proceeding against the Contractor and notwithstanding any security or other guarantee the TIFR-Hyderabad may have in relation to the Contractor's liabilities.

7. This guarantee will not be discharged due to the change in the constitution of the Bank or the Contractor.

8. We,..... (indicate the name of the Bank), undertake not to revoke this guarantee except with the consent of the TIFR-Hyderabad in writing.

9. This Bank Guarantee shall be valid up to Unless extended on demand by the TIFR-Hyderabad. Notwithstanding anything mentioned above, our liability against this guarantee is restricted to Rs. (Rupees only) and unless a claim in writing is lodged with us within the date of expiry or extended date of expiry of this guarantee, all our liabilities under this guarantee shall stand discharged.

Date

Witness:

1. Signature

Authorized signatory

Name and address

Name

Designation

Staff Code no.

Bank Seal Name and Address

2. Signature

Note:

1. *Date to be worked out on the basis of validity period of 75 days where only financial bids are invited and 180 days for two / three bid system from the date of submission of tender.

2. ** In paragraph 1, strike out the portion not applicable. Bank Guarantee will be made either for performance guarantee / security deposit / mobilization advance, as the case may be. The Bank Guarantee shall be drawn on non-judicial stamp paper of minimum Rs.100.



SECTION-V

General Conditions of Contract

1. General

1.1. Definitions

Terms that are defined in the Contract Data are not also defined in the Conditions of Contract but keep their defined meanings. Capital initials are used to identify defined terms.

EMPLOYER: Means the TIFR-Hyderabad, acting through the Head, Engineering Unit, TIFR-Hyderabad or successor thereof

BIDDER: Means the individual, proprietary firm, firm in partnership, limited company (private or public) or corporation. Joint ventures, consortiums and Special Purpose Vehicles are not accepted as bidders.

COMPLETION DATE: is the date of completion of the Works as certified by the Engineer In-charge or his nominee.

CONTRACT is the contract between the Employer and the Contractor to execute, complete and maintain the Works.

The Contract Data defines the documents and other information which comprise the Contract. A Defect is any part of the Works not completed in accordance with the Contract.

2. Contract Agreement

2.1. Agreement will be framed based on the tender conditions with the successful bidder. Upon signing the Contract Agreement, the Contractor shall make copies of Contract Documents, as indicated in the Contract Data, in hardbound cover which shall cover documents used in Contract/Agreement and provide the same to the Employer at no extra cost.

2.2. Data made available by the Employer in accordance with provisions of the Condition of Contract shall be deemed to include data listed elsewhere in the Contract and open for inspection at the office of the Engineer as indicated in the Contract data of the TIFR-Hyderabad (by prior appointment with the Engineer).

3. Personnel

3.1. The Contractor shall employ the key personnel to carry out the functions as per the tender conditions approved by the Engineer or his nominee. The Engineer or his nominee will approve any proposed replacement of key personnel only if their qualifications, abilities, and relevant experience are substantially equal to or better than those of the personnel listed in the schedule.



3.2. If the Engineer or his nominee asks the Contractor to remove a person who is a member of the Contractor's staff of from his work force stating the reasons, the Contractor shall ensure that the person leaves the site within seven days and has no further connections with the work in the contract.

4. Insurance

4.1. The Contractor shall provide in the joint names of the Employer and the Contractor, insurance cover from the Start Date till completion of Operations and maintenance period, in the amounts and deductibles stated in the Contract Data for the following events which are due to the Contractors risks. a) loss of or damage to the Works, Plant and Materials b) loss of or damage to Equipment; c) loss of or damage of property in connection with the Contract; and d) personal injury or death.

4.2. Policies and certificates for insurance shall be delivered by the Contractor to the Engineer or his nominee for approval before the start date. All such insurances shall provide for compensation to be payable in the types and proportions of currencies required to rectify the loss or damage incurred.

4.3. If the Contractor does not provide any of the policies and certificates required, the Employer may effect the insurance which the Contractor should have provided and recover the premiums the Employer has paid from any payments due to the Contractor or, if no payment is due, the payment of the premiums shall be a debt due.

4.4. Alterations to the terms of insurance shall not be made without the approval of the Engineer in-charge or his nominee.

4.5. Both parties shall comply with all conditions of the insurance policies

5. Contractor to Construct the Works

5.1. The Contractor shall construct and install the works in accordance with the Specification and Drawings.

5.2. The Contractor shall execute the whole and every part of the work in the most substantial and workmanlike manner both as regards materials and otherwise in every respect in strict accordance with the Specifications. The Contractor shall also conform exactly, fully and faithfully to the design, drawings and instructions in writing in respect of the work signed by the Engineer or his nominee and the Contractor shall be furnished free of charge one copy of the contract documents together with specifications, designs, drawings and instructions as are not included in the Specifications specified in Contract Data or in any Bureau of Indian Standard or any other published standard or code or, Schedule of Rates or any other printed publication referred to elsewhere in the Contract.

5.3. The Contractor shall comply with the provisions of the contract and with the care and diligence execute and maintain the works and provide all labour and materials, tools



and plants including for measurements and supervision of all works, structural plans and other things of temporary or permanent nature required for such execution and maintenance in so far as the necessity for providing these, is specified or is reasonably inferred from the contract. The Contractor shall take full responsibility for adequacy, suitability and safety of all the works and methods of construction.

6. The Works to be Completed by the Intended Completion Date

- 6.1. The Contractor may commence execution of the works on the Start Date and shall carry out the works in accordance with the program submitted by the Contractor as updated with the approval of the Engineer or his nominee, and complete them by the Intended Completion Date.

7. Approval by the Engineer in-charge or his nominee

- 7.1. The Contractor shall submit Specifications and Drawings showing the proposed Temporary Works or Permanent Works, in the case of Contractor's design to the Engineer or his nominee, who is to approve them if they comply with the specifications and Drawings.
- 7.2. The Contractor shall be responsible for the design of Temporary Works.
- 7.3. The Engineer or his nominee's Approval shall not alter the Contractor's responsibility for design of the Temporary Works.
- 7.4. All Drawings prepared by the Contractor for the execution of the temporary works, are subject to prior approval by the Engineer or his nominee before their use.

8. Safety

- 8.1. The Contractor shall be responsible for the safety of all activities on the Site.
- 8.2. All personnel should use PPE during the period of construction/erection.
- 8.3. The Contractor shall have his own staff at the site, an officer dealing with all matters regarding safety and protection against accidents of all staff and labor. This officer shall be qualified for this work and shall have the authority to issue instructions and shall take protective measures to prevent accidents.

9. Force Majeure

"Force Majeure" means an exceptional event or circumstance:

- (a) Which is beyond a Party's control,
(b) Which such Party could not reasonably have provided against before entering into the Contract,
(c) Which, having arisen, such Party could not reasonably have avoided or overcome
(d) Which is not substantially attributable to the other Party.



Force Majeure may include, but is not limited to, exceptional events or circumstances of the kind listed below, so long as conditions (a) to (d) above are satisfied:

- (i) War and hostilities (whether war be declared or not), invasion, act of foreign enemies;
- (ii) Rebellion, revolution, insurrection, or military or usurped power, or civil war;
- (iii) Ionizing radiations, or contamination by radioactivity from any nuclear fuel, or from any nuclear waste, from the combustion of nuclear fuel, radioactive toxic explosive or other hazardous properties of any explosive nuclear assembly or nuclear component thereof;
- (iv) Pressure waves caused by aircraft or other aerial devices traveling at sonic or supersonic speeds; and
- (v) Riot, commotion or disorder, unless solely restricted to the employees of the Contractor or of his Sub Contractors and arising from the conduct of the Works;
- (vi) Floods, tornadoes, earthquakes and landslides.

10. Settlement of Disputes & Arbitration

10.1. General

10.2. Except where otherwise provided in the contract all questions and disputes relating to the meaning of the specifications, design, drawings and instructions here-in before mentioned and as to the quality of workmanship or materials used on the work or as to any other question, claim, right, matter or thing whatsoever in any way arising out of or otherwise concerning the works or the execution or failure to execute the same whether arising during the progress of the work or after the cancellation, termination, completion or abandonment thereof shall be dealt with as mentioned hereinafter:-

10.3. If the Contractor considers any work demanded of him to be outside the requirements of the contract, or disputes any drawings, record or decision given in writing by the Engineer on any matter in connection with or arising out of the contract or carrying out of the work, to be unacceptable, he shall promptly within 15 days request the Engineer in writing for written instruction or decision. Thereupon, the Engineer shall give his written instructions or decision within a period of one month from the receipt of the Contractor's letter. If the Engineer fails to give his instructions or decision in writing within the aforesaid period or if the Contractor is dissatisfied with the instructions or decision of the Engineer, the Contractor may, within 15 days of the receipt of Engineer's decision, appeal to the Chairman, Engineering Unit, TIFR-Hyderabad who shall afford an opportunity to the Contractor to be heard, if the latter so desires, and to offer evidence in support of his appeal. The Chairman, Engineering Unit, TIFR-Hyderabad shall give his decision within 30 days of receipt of Contractor's appeal. If the Contractor is dissatisfied with this decision then:



- a. The Dispute in respect of contract of value up to Rs. 1crore shall not be referred for adjudication through arbitration and.
- b. If the value of the contract is exceeding Rs. 1 crore and up to Rs.5 crores,
 - i. The Dispute shall be resolved through arbitration by a sole arbitrator appointed by the Dean Planning & Infrastructure of TIFR-Hyderabad.
 - ii. The Contractor shall within a period of 30 days from receipt of the decision of the Dean Planning & Infrastructure, give notice to the Dean Planning & Infrastructure for appointment of arbitrator, failing which, the said decision shall be final, binding and conclusive and not referable to adjudication by the arbitrator. If the arbitrator so appointed is unable or unwilling to act or resigns his appointment or vacates his office due to any reason whatsoever another sole arbitrator shall be appointed in the manner aforesaid. Such person shall be entitled to proceed with the reference from the stage at which it was left by his predecessor.

11. Identify Defects

- 11.1. The Engineer or his nominee shall check the Contractor's work and notify the Contractor of any defects that are found. Such checking shall not affect the Contractor's responsibilities. The Engineer or his nominee may instruct the Contractor to search for a Defect and to uncover and test any work that the Engineer or his nominee considers may have a Defect.

12. Tests

- 12.1. If the Engineer or his nominee instructs the Contractor to carry out a test not specified in the Specification to check whether any work has a Defect and if the test shows that it has defect, the Contractor shall pay for the test and any samples. If there is no Defect the test shall be a Compensation Event.

13. Compliance with labour regulations.

- 13.1. During continuance of the contract, the Contractor and his sub-Contractors shall abide at all times by all existing labour enactment and rules made there under, regulations, notifications and bye laws of the State or Central Government or local authority and any other labour law (including rules) regulations, bye laws that may be passed or notification that may be issued under any labour law in future either by the State or Central Government or the local authority. Salient features of some of the major labour laws that are applicable to construction industry are given below. The Contractor shall keep the Employer indemnified in case any action is taken against the Employer by the competent authority on account of contravention of any of the provisions of any Act or rules made there under, regulations or notifications including amendments. If the



Employer is caused to pay or reimburse such amounts as may be necessary to cause or observe, or for non-observance of the provisions stipulated in the notifications/ bye laws/ Acts/ Rules/ regulations including amendments, if any, on the part of the Contractor the Engineer or his nominee/Employer shall have the right to deduct any money due to the Contractor including his amount of performance security. The Employer/Engineer or his nominee shall also have right to recover from the Contractor any sum required or estimated to be required for making good the loss or damage suffered by the Employer.

- 13.2. The employees of the Contractor and the Sub-Contractor in no case shall be treated as the employees of the Employer at any point of time.

14. Labour Laws & Regulations

- 14.1. The Contractor shall at all times during the continuance of the Contract comply fully with all existing Acts, regulations and bye-laws including all statutory amendments and re-enactment of State or Central Govt. and other local authorities and any other enactments and act that may be passed in future either by the State or the Central Govt. or local authority, including Indian Workmen's Compensation Act, Contract Labour (Regulation And Abolition) Act 1970 and Equal Remuneration Act 1976, Employees' State Insurance Act, 1948, Factories Act, Minimum Wages Act, Provident Fund.

15. Fair Wages, Records, Inspection

- 15.1. The Contractor shall pay the labourers engaged by him on the work not less than a fair wage which expression shall mean whether for time or piecework the respective rates of wages as notified under the provisions of the Minimum Wages Act from time to time. The Contractor shall maintain records of Wages and other remuneration paid to his employee in such form as may be convenient and to the requirements of the Employer/Engineer and the Labour Enforcement Officer (Central), Ministry of Labour, Govt. of India, or such other authorized person appointed by the Central Govt. The Contractor shall allow inspection of the aforesaid Wage Records and Wage Slips to the Engineer and to any of his workers or to his agent at a convenient time and place after due notice is received, or to any other person authorized by him on his behalf.

16. Power and Water Supply

- 16.1. The Power and Water required for the construction works will be shown in the respective building itself. However, the contractor has to make his own arrangement to tap the power and water. No charges will be collected by the Institute for power & water.

17. Daily reports

- 17.1. The Contractor shall submit daily report indicating daily activities, weather condition, actual manpower, equipment and the materials arriving on site.



टाटा मूलभूत अनुसंधान संस्थान
TATA INSTITUTE OF FUNDAMENTAL RESEARCH
भारत सरकार के परमाणु ऊर्जा विभाग की स्वायत्त संस्था एवं समविश्वविद्यालय
(Autonomous Institution of the Department of Atomic Energy, Government of India)
सर्वेक्षण संख्या 36 / पी, गोपनपल्ली गांव, सेरिलिंगमपल्ली मंडल, रंगारेड्डी जिला, हैदराबाद - 500 046
Survey No.36/P, Gopanpally Village, Serilingampally Mandal, Ranga Reddy District,
Hyderabad-500046, Telangana

PRICE BID

VOLUME-2

Setting up of “500 KWp Grid-connected Rooftop Solar PV Power Plant under RESCO mode” at TIFR, Survey No. 36/P, Gopanpally (Village), Serilingampally (Mandal), Ranga Reddy Dist., Hyderabad-500046 including Operation & Maintenance (O & M) of the project for a period of 25 (Twenty-five) years after operational acceptance”.



SECTION-VI

Price Bid

PRICE BID

Each bidder shall provide, as a part of its financial proposal provide the flat tariff/ charges per unit for a period of twenty-five (25) years and the same shall be made part of the PPA

Description	Tariff (in Rs./kWh)
Flat tariff/ charges per unit for a period of 25 years	

Certified that:

- 1) Above rates are in accordance with the all the specifications, various terms, conditions and requirements mentioned in this tender document, to perform the work satisfactorily.
- 2) The rates are inclusive of all taxes and duties whatsoever.

Note:-

- 1) The tariff/charges shall be calculated up to two decimal places.
- 2) Bids not in conformity with above provisions will be rejected.
- 3) If TIFR-Hyderabad not able to utilize or take-off power from roof top solar power system due power distribution issues, then deemed generation is applicable. Power producer to submit necessary calculations considering the solar irradiation.
- 4) Real time solar irradiation meter with historical trends to be installed at site. This will help in arriving the deemed generation.

Date:

Signature:

Designation:

Place:

(Company Stamp)

Main Building Layout Drawing

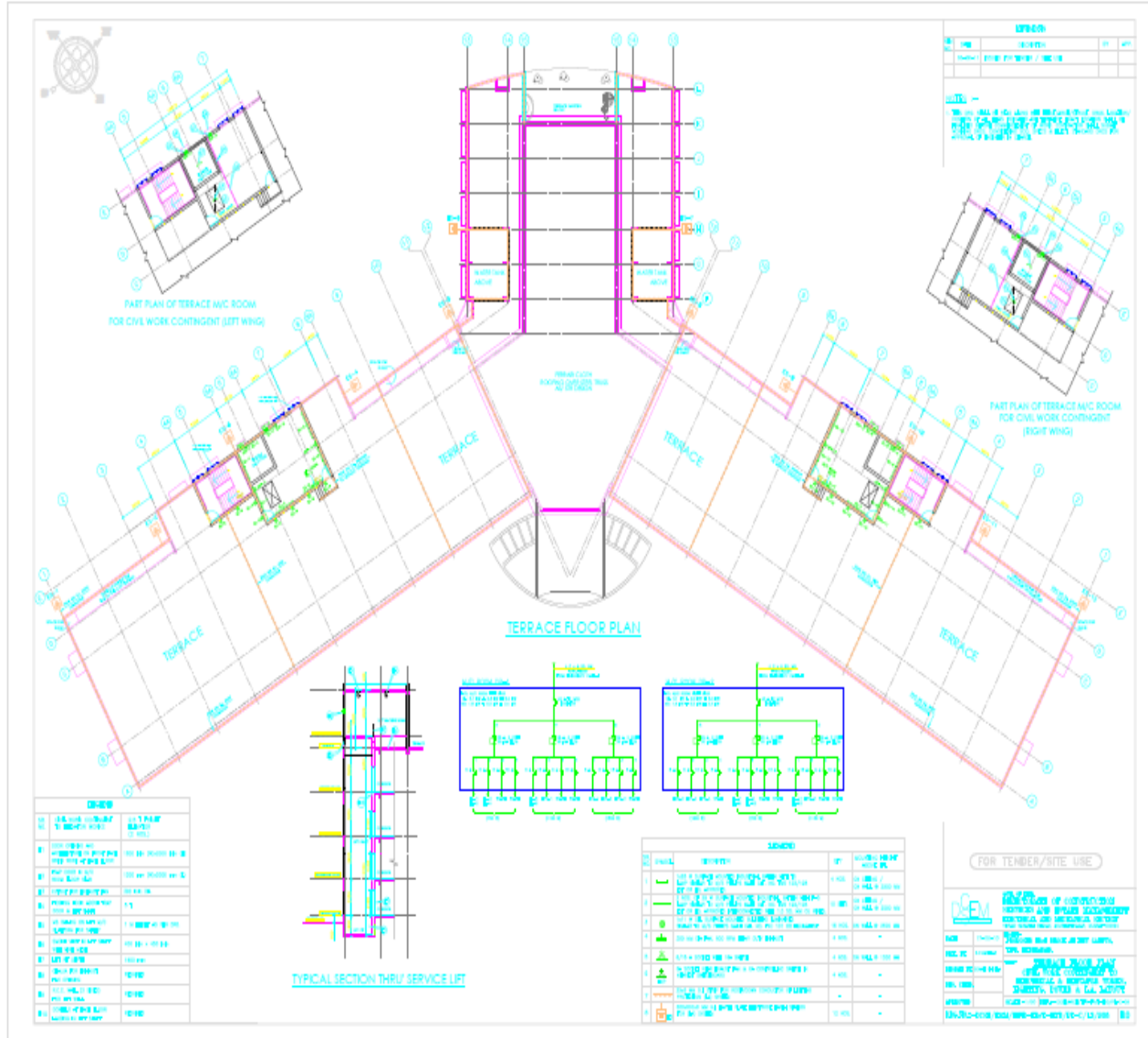

Service Building-1 Layout Drawing

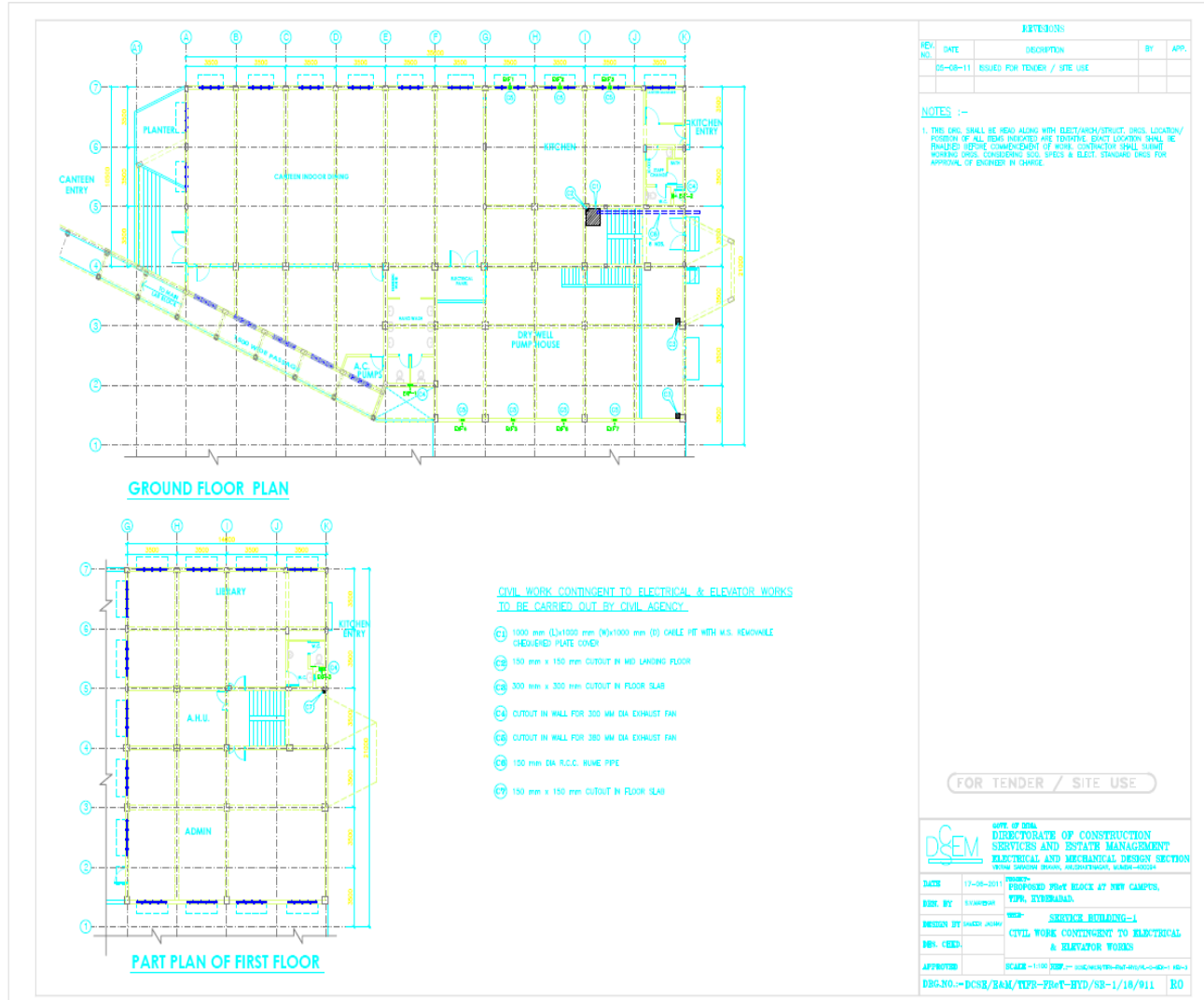

Hostel-1 Layout Drawing

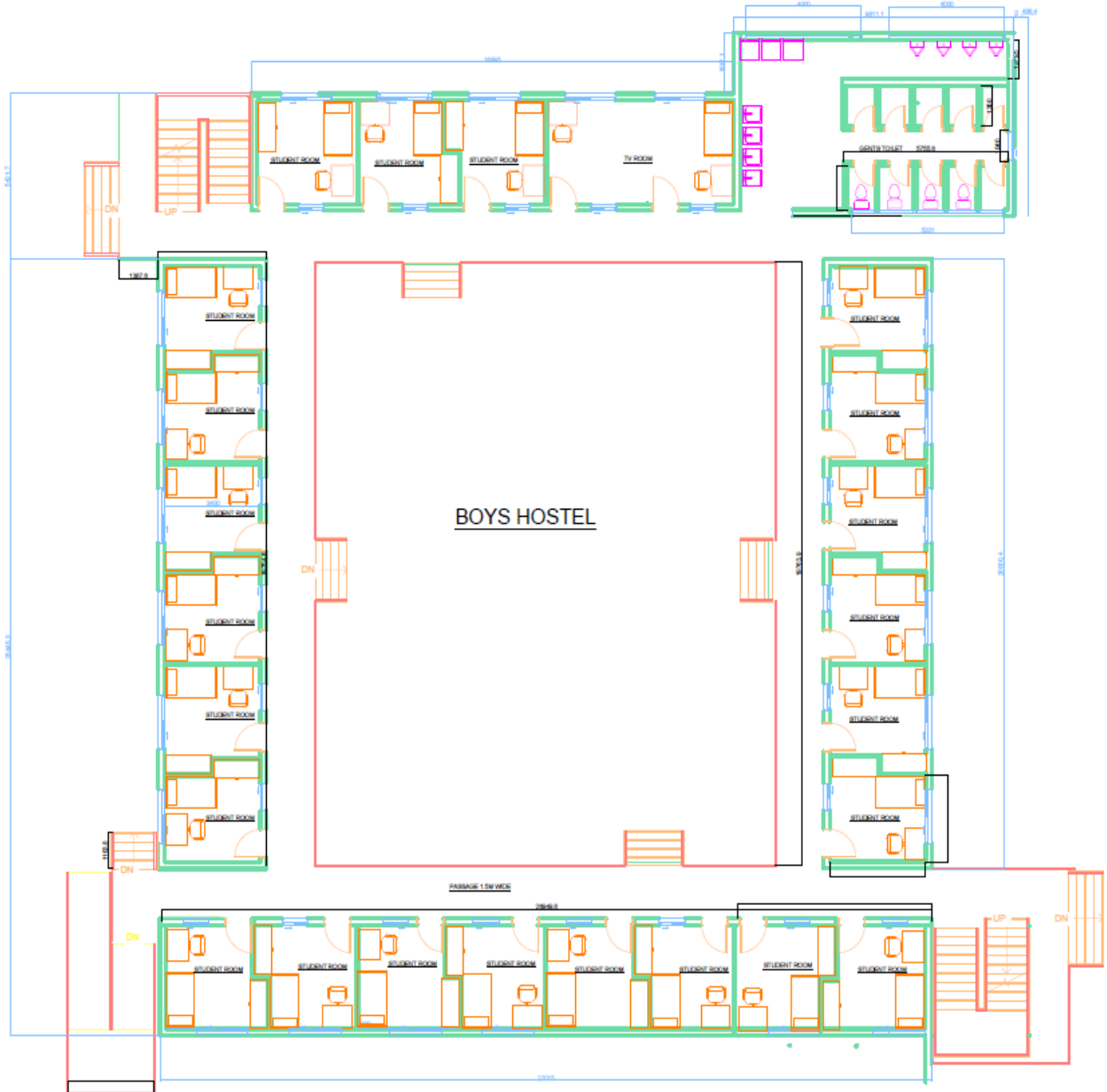

Hostel-2 Layout Drawing

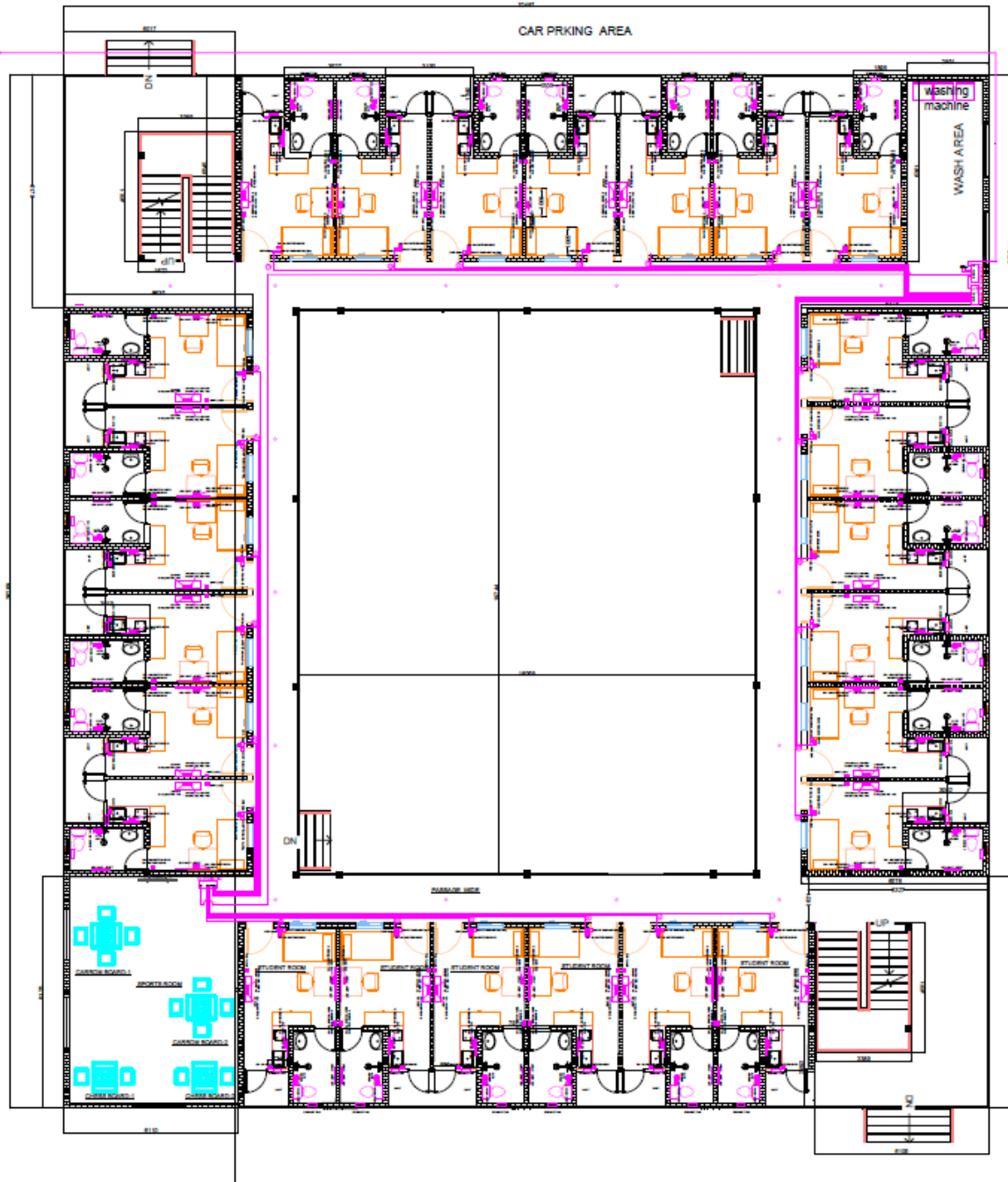

Hostel-3 Layout Drawing

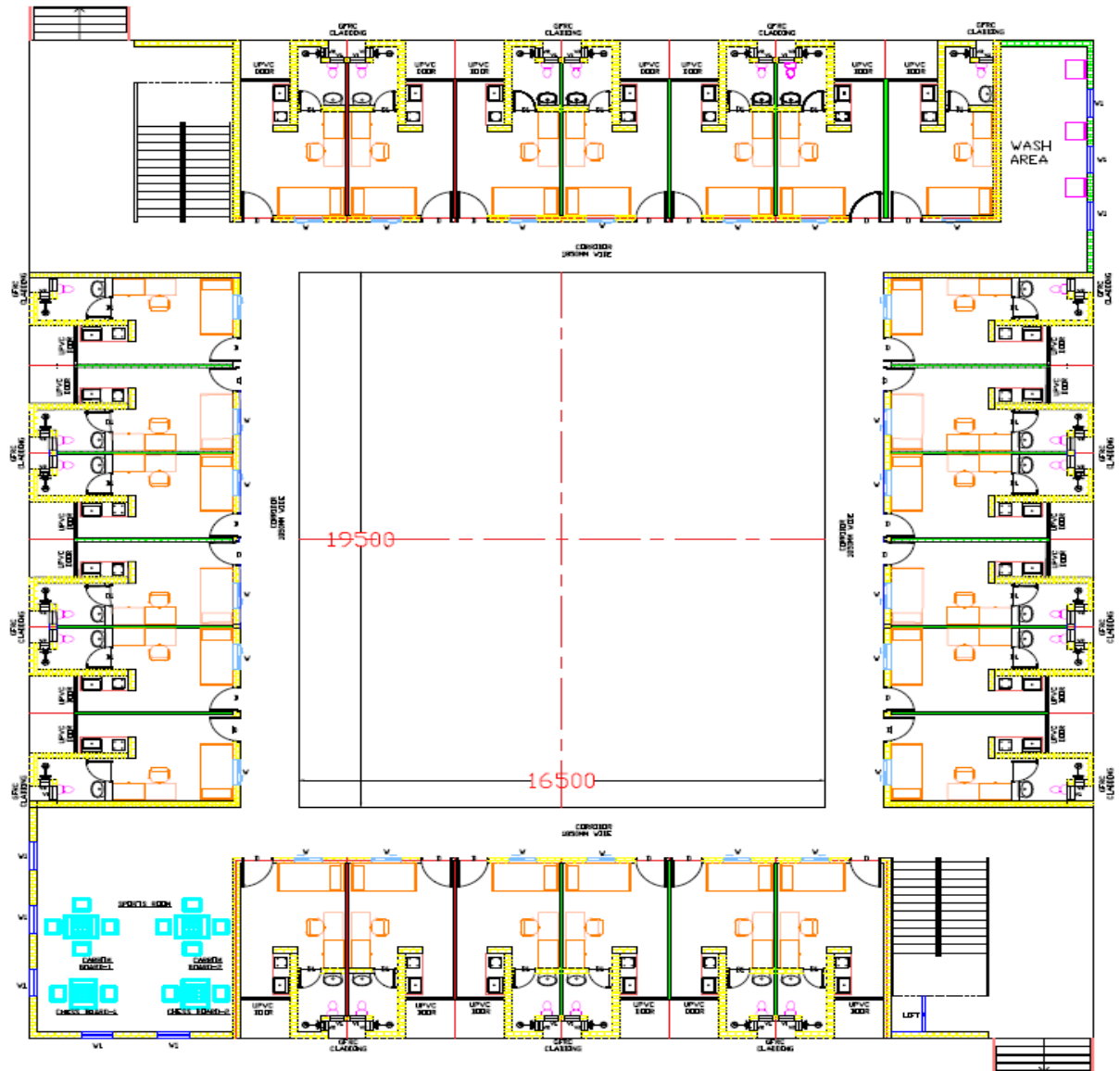

Hanger Building-1 Layout Drawing

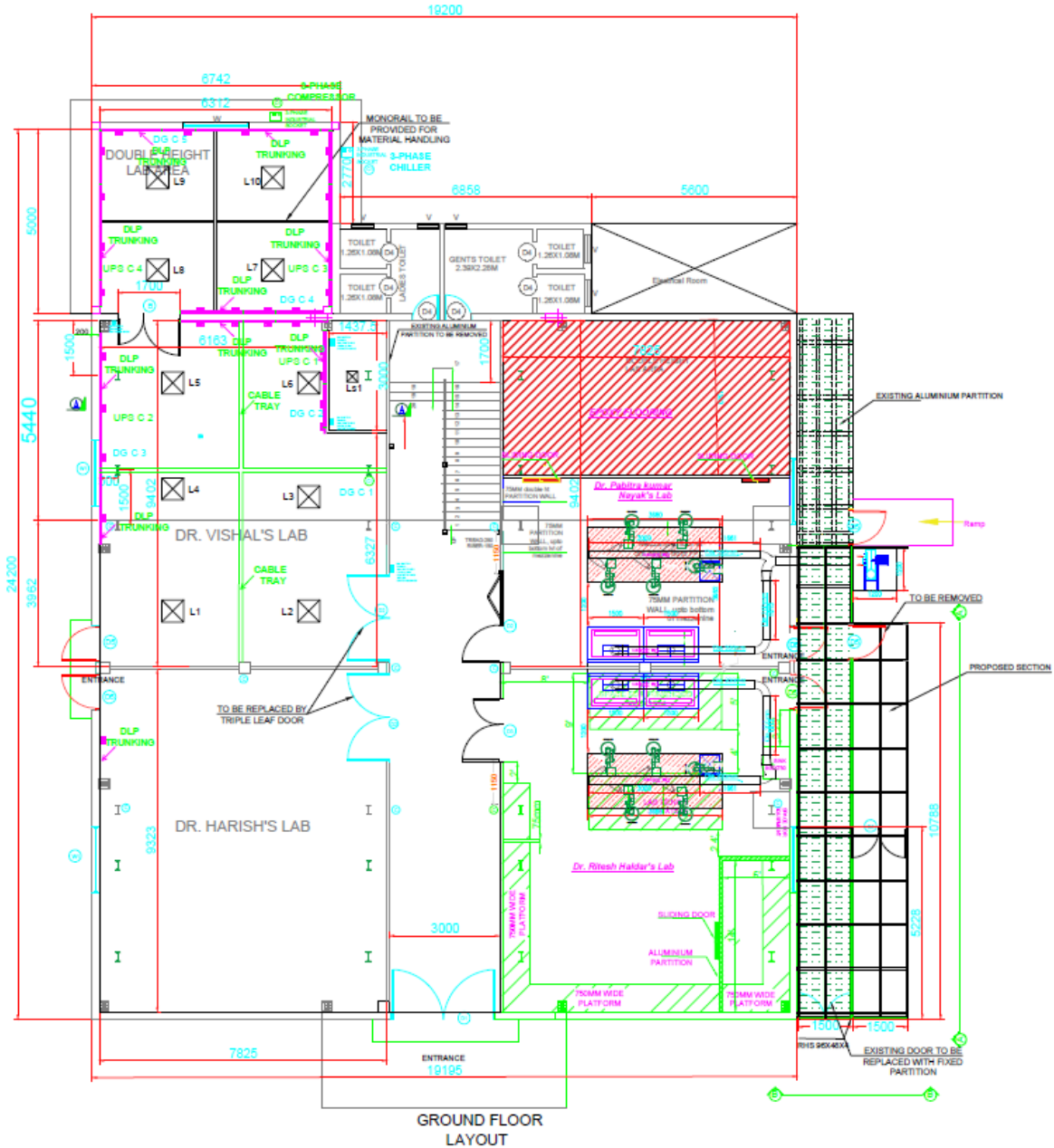

Hanger Building-2 Layout Drawing

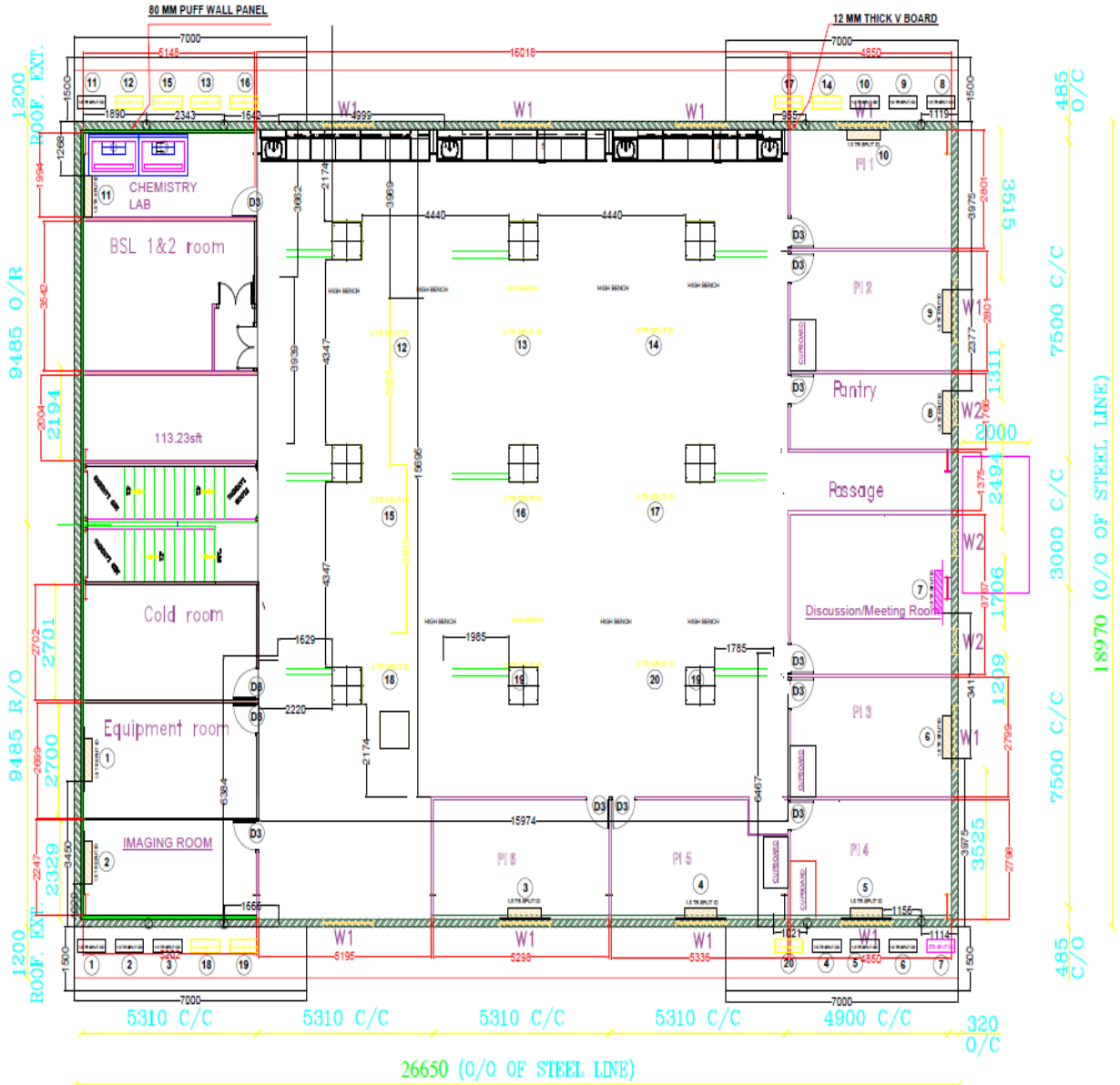

Petawatt Laser Lab Layout Drawing

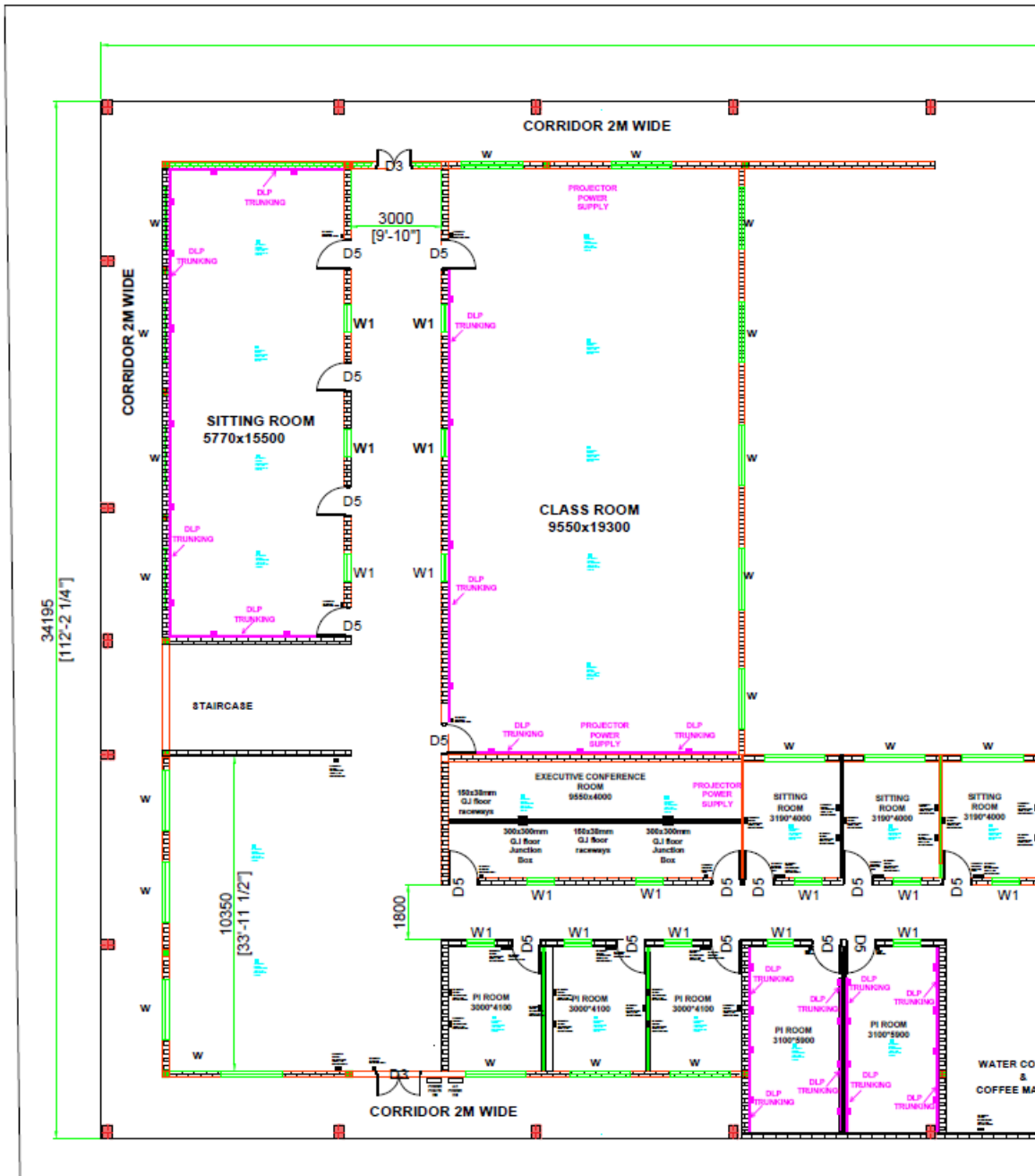

HT Power Single Line Drawing

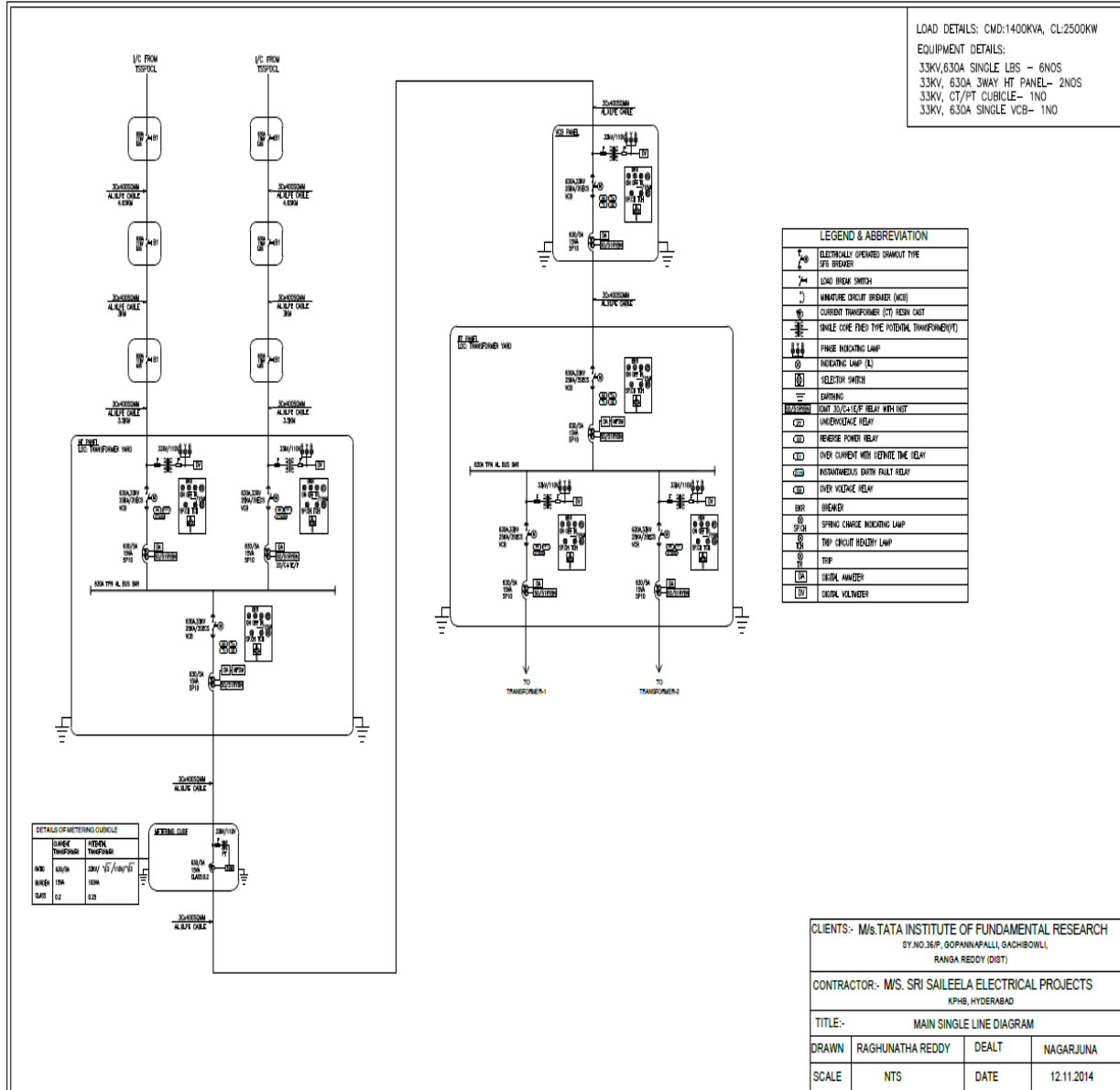

Service Building-2 HT & LT Power Single Line Drawing

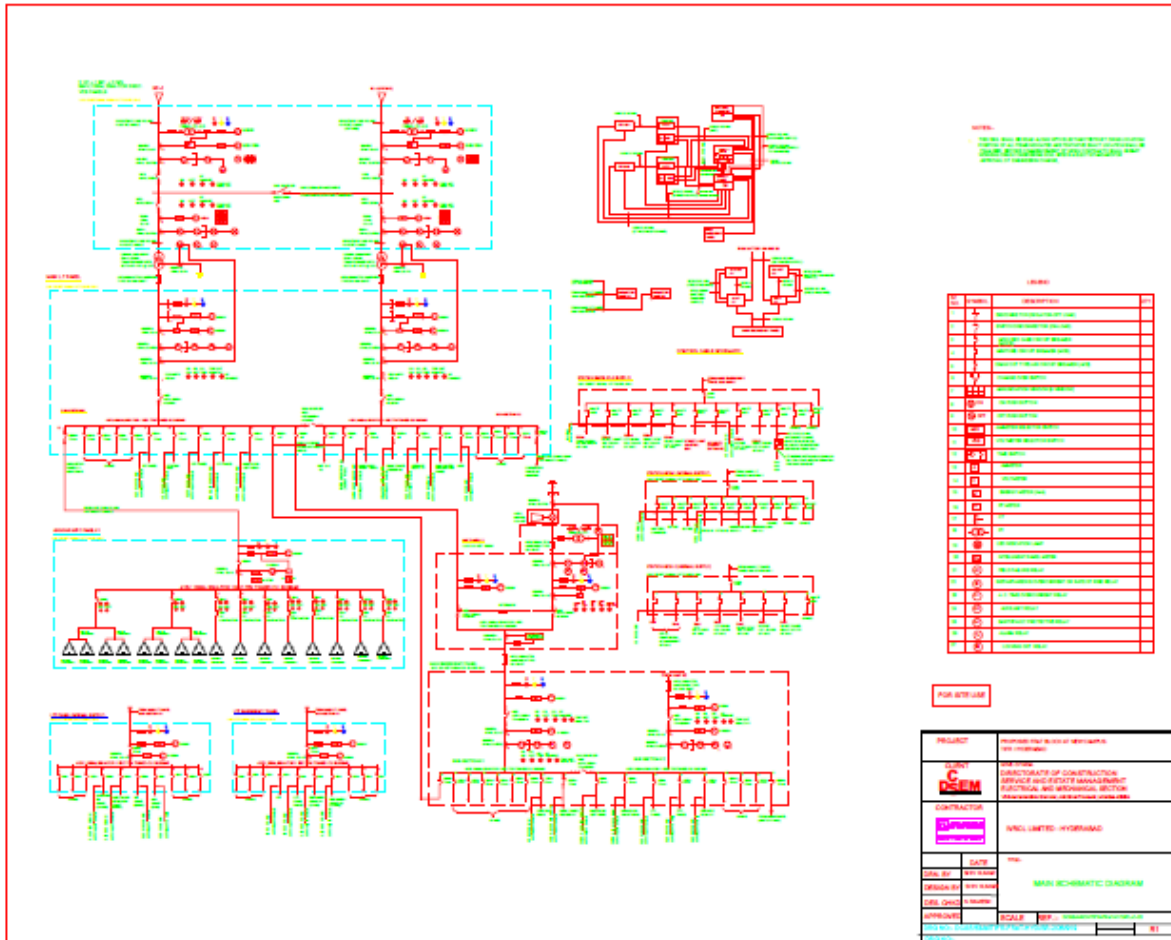



टाटा मूलभूत अनुसंधान संस्थान
TATA INSTITUTE OF FUNDAMENTAL RESEARCH
 भारत सरकार के परमाणु ऊर्जा विभाग की स्वायत्त संस्था एवं समविश्वविद्यालय
 (Autonomous Institution of the Department of Atomic Energy, Government of India)
 सर्वेक्षण संख्या 36 / पी, गोपनपल्ली गांव, सेरिलिंगमपल्ली मंडल, रंगारेड्डी जिला, हैदराबाद - 500 046
 Survey No.36/P, Gopanpally Village, Serilingampally Mandal, Ranga Reddy District,
 Hyderabad-500046, Telangana

Service Building-2 STP & Rain Harvesting Power Single Line Drawing

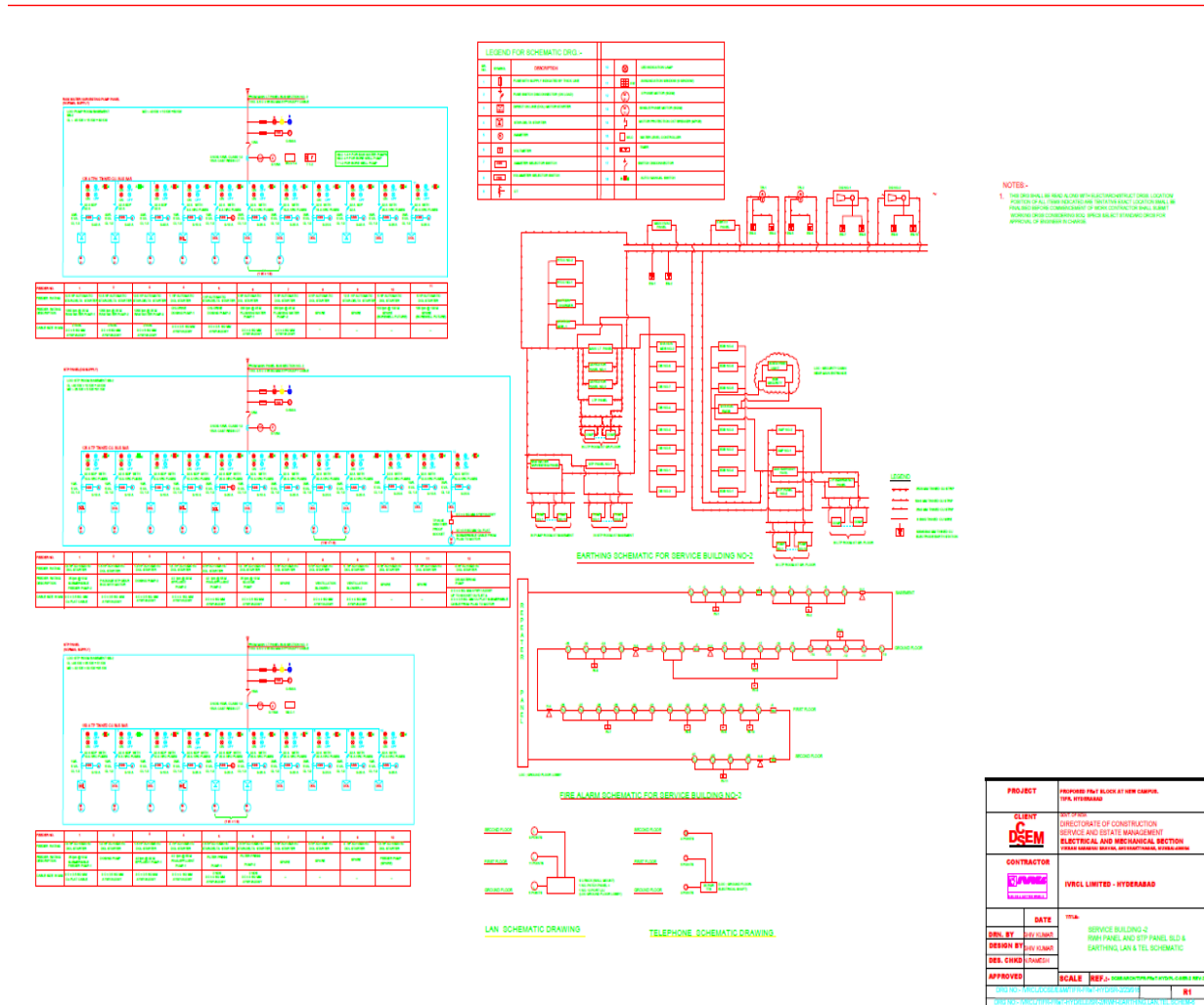



Hanger Building-1 LT Power Single Line Drawing

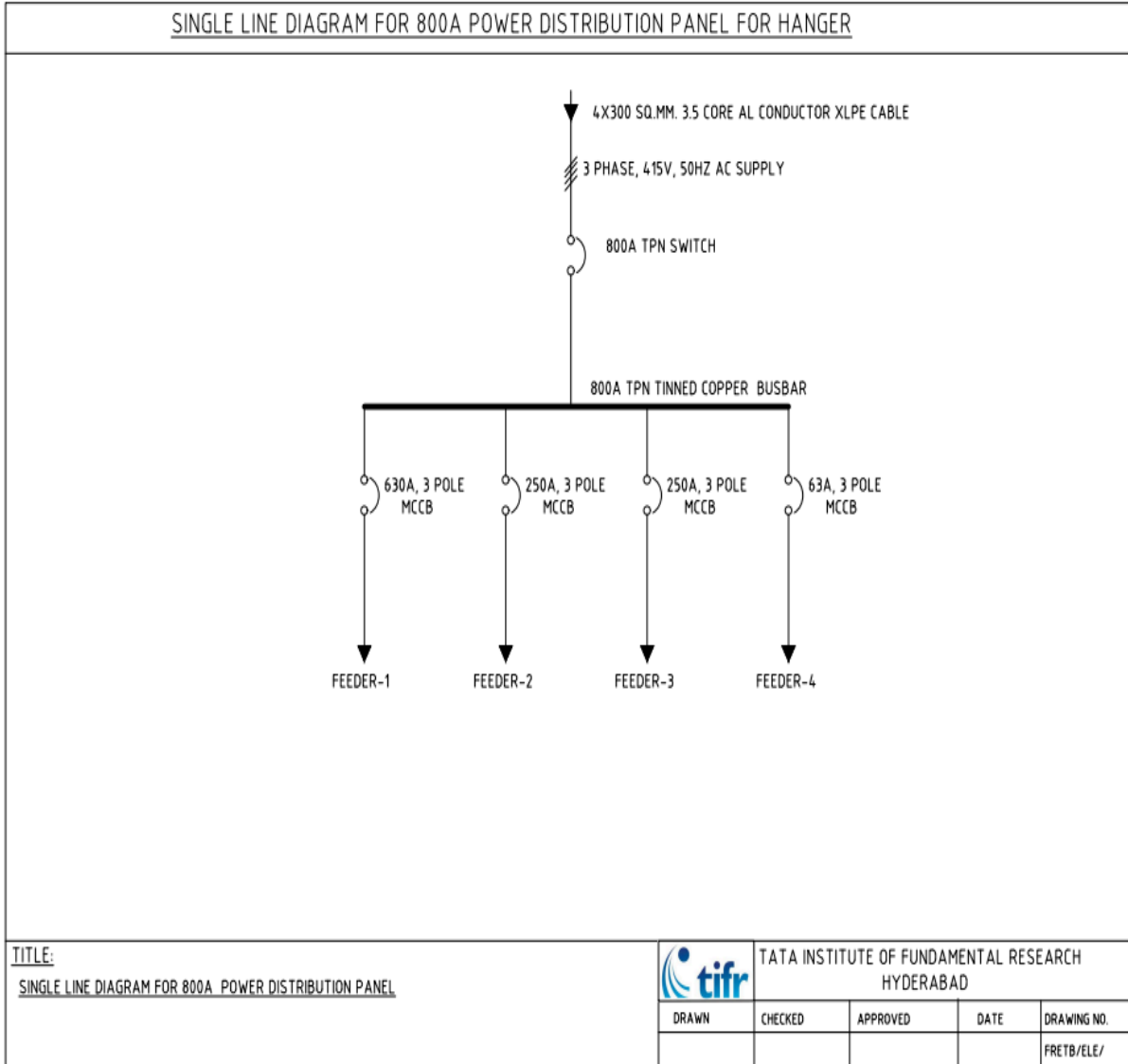

Hanger Building-2 AHU Power Single Line Drawing

