



Telephone: +40 2020 3010	Date: 07.11.2023
Website: <a href="http://www.tifrh.res.in">www.tifrh.res.in</a>	Email: <a href="mailto:rajasekharr@tifrh.res.in">rajasekharr@tifrh.res.in</a>

**PUBLIC TENDER**

**(TWO PART TENDER) for the following Works:**

<b>Construction of Roof Covering Shed for Beam Hall at Plot-B, TIFR, Survey No. 36/P, Gopanpally (Village), Serilingampally (Mandal), Ranga Reddy Dist., Hyderabad-500046.</b>	
<b>Tender No.</b>	<b>TIFR/PD/CF23-116/230997</b>
<b>Type of Tender</b>	<b>Two Part Tender (Part-I: Technical Bid and Part-II: Price Bid)</b>
<b>Estimated Cost</b>	<b>Rs.1,43,21,812/-</b>
<b>Cost of EMD</b>	<b>Rs.2,86,450/- (Demand Draft to be drawn in favour of “Tata Institute of Fundamental Research”, Payable at Hyderabad (To be enclosed with the Technical Bid Part – I)).</b>
<b>Pre bidding meeting &amp; Time</b>	<b>10.11.2023 at 11:00 Hrs</b>
<b>Last Date for Submission of Tender</b>	<b>15.11.2023 by 13:00 Hrs</b>
<b>Date of Opening Bids(Only Part-I: Technical Bid)</b>	<b>15.11.2023 at 15:00 Hrs</b>
<b>Tender Fee</b>	<b>Rs.1000/-(Demand Draft to be drawn in favour of “Tata Institute of Fundamental Research”, Payable at Hyderabad (To be enclosed with the Technical Bid Part –I)).</b>

- In case the Part “I” and Part “II” bids are not sealed in separate envelopes the tender will be rejected.
- The technical bid should not contain any indication of the price.
- The Technical Bid received without payment of tender fees and EMD shall be summarily rejected.
- Quotation sent by hand delivery/courier are to be handover at security after obtaining stamp, date and signature of the concern person at security.
- Contact Mr. Ashis panigrahi, Tel: 040-2020 3004/9102945867, Email Id: [ashispanigrahi@tifrh.res.in](mailto:ashispanigrahi@tifrh.res.in) for any technical or commercial terms clarifications mentioned in the tender.



Sealed tenders are invited for the aforesaid works from contractors having similar work experience in reputed Research Institutions, Universities, Central Government/Public Sector Undertaking, Private Laboratories, Multinational Companies, etc. Interested contractors who are satisfying prequalification criteria stipulated by TIFR-Hyderabad shall only submit their bids. For further details and any clarification on the tender you may please contact Head- Technical Services, Survey No.36/P, Gopanpally Village, Serilingampally Mandal, Ranga Reddy District, Hyderabad - 500046.

**Last date for submission of the tender is 15.11.2023 by 13:00 Hrs.**

A handwritten signature in black ink, appearing to read 'Rajasekhar. R', with a checkmark at the end.

**(Rajasekhar. R)**  
**Head-Technical Services**



---

**TENDER DOCUMENT**

**Construction of Roof Covering Shed for Beam Hall at Plot-B,  
TIFR, Survey No. 36/P, Gopanpally (Village), Serilingampally  
(Mandal), Ranga Reddy Dist., Hyderabad - 500 046.**

**NAME OF THE TENDERER:** .....

**Address:** .....

.....  
.....  
.....

**Last date of submission of the tender: On or before 15.11.2023 by 13:00 Hrs.**



**INVITATION OF BIDS**

**FOR**

**Construction of Roof Covering shed for Beam Hall at Plot-B,  
TIFR, Survey No.36/P, Gopanpally (Village), Serilingampally  
(Mandal), Ranga Reddy Dist., Hyderabad – 500 046.**

**TECHNICAL BID**

**PART-I**



<b>Tender Notice</b>	<b>:</b>	<b>TIFR/PD/CF23-116/230997</b>
<b>Name of Work</b>	<b>:</b>	<b>Construction of Roof Covering Shed for Beam Hall at Plot-B, TIFR, Hyderabad.</b>
<b>Location</b>	<b>:</b>	<b>Tata Institute of Fundamental Research Survey No. 36/P, Gopanpally Village, Serilingampally Mandal, Ranga Reddy District, Hyderabad – 500046.</b>
<b>Estimated Cost</b>	<b>:</b>	<b>Rs.1,43,21,812 /-</b>
<b>EMD</b>	<b>:</b>	<b>Rs.2,86,450/- (Demand Draft to be drawn in favour of “Tata Institute of Fundamental Research”, Payable at Hyderabad (To be enclosed with the Technical Bid Part – I))</b>
<b>Delivery Period</b>	<b>:</b>	<b>180 Days (Completion Period)</b>
<b>Validity</b>	<b>:</b>	<b>Seventy Five (75) days after opening of Part-I, Technical Bid</b>

---

## **INDEX**

<b>SECTION</b>	<b>DESCRIPTION</b>	<b>PAGE NO.</b>
SECTION I	IMPORTANT INFORMATION	7-9
SECTION II	ELIGIBILITY CRITERIA FOR QUALIFICATION OF TENDER	10-16
SECTION III	NOTICE & INSTRUCTIONS	17-22
SECTION IV	GENERAL INFORMATION	23-24
SECTION V	GENERAL CONDITIONS	25-38
SECTION VI	SPECIAL CONDITIONS OF CONTRACT	39-47
SECTION VII	TECHNICAL CONDITIONS & SPECIFICATIONS	48-146
SECTION VIII	DRAWINGS	147-150
SECTION IX	ANNEXURES	151-157
SECTION X	FINANCIAL BID (PART II)	158-164

<b>SECTION-I</b>	<b>IMPORTANT INFORMATION</b>
------------------	------------------------------

**INTRODUCTION**

The Tata Institute of Fundamental Research is a National Centre of the Government of India, under the umbrella of the Department of Atomic Energy, as well as a deemed University awarding degrees for master’s and doctoral programs. Tata Institute of Fundamental Research Centre for Interdisciplinary Sciences, Hyderabad invites bids for the following work:

**Name of Work: Construction of Roof Covering Shed for Beam Hall at Plot-B, TIFR, Survey No. 36/P, Gopanpally (Village), Serilingampally (Mandal), Ranga Reddy Dist., Hyderabad-500 046.**

**1. PARTICULARS**

a)	Considered area	1050 Sqm
b)	Location	TIFR, Survey No. 36/P, Gopanpally (Village), Serilingampally (Mandal), Ranga Reddy Dist., Hyderabad-500046.
c)	Pre-Bid Meeting Date & Time	10.11.2023 at 11:00 Hrs
d)	Closing date & time of receipt of bids	15.11.2023 by 13:00 Hrs
e)	Date & time of opening of Sealed Cover-I containing Technical Bid	15.11.2023 at 15:00 Hrs.
f)	Date of opening of Sealed cover-II containing Financial Bid of eligible bidders	To be intimated to eligible bidders after completion of technical evaluation.

**2. GENERAL INSTRUCTIONS**

- 2.1. TIFR shall award the contract for the project through the two Bid systems.
- 2.2. The Contractors are advised to visit and examine the site of work and its surroundings and obtain any information that may be necessary, in addition to those provided in this document. The Contractor shall be deemed to have fully acquainted himself about the site condition, whether he inspects it or not.
- 2.3. The Contractor should adhere to the building bye-laws applicable for the area.
- 2.4. All clarifications shall be sought before the date of pre-bid meeting. The bidders may make suggestions which shall be considered during the Pre Bid Meeting. No further clarifications shall be issued after the issue of noteworthy replies to the pre-bid queries.
- 2.5. The submission of the bid by Contractor would imply that they have carefully read and agreed to the terms and conditions contained in this bid document.

- 2.6. The bid for the work shall remain open for acceptance for a period of **75 (Seventy Five) days** from the date of submission of the bids, which period may be extended by mutual agreement and the Contractor shall not cancel or withdraw the offer during this period. This bid document shall form a part of the contract agreement.
- 2.7. Fluctuation: Bidder must consider the price fluctuation going to happen in the bid validity period (i.e, 75 days + execution period 180 days).
- 2.8. Action for withdrawal: The bidder can't withdraw the bid within the validity period. If any bidder withdraws his bid during above said period then action will be taken as per tender clause & declaration.

### **3. SUBMISSION OF BIDS:**

Bids shall be submitted to Head- Technical Services, **TIFR, Survey No. 36/P, Gopanpally (Village), Serilingampally (Mandal), Ranga Reddy Dist, Hyderabad-500046** in a sealed Master envelope super scribed "Bid for **Construction of Roof Covering Shed for Beam Hall at Plot-B, TIFR** with our enquiry no. and due date, containing two separate sealed covers clearly super scribed as "**Technical Bid**" and "**Financial Bid**" before the closing date and time of submission in the following manner:

- a) "**Technical Bid**": This will contain Technical part, Eligibility Documents along with testimonials. Earnest Money Deposit (EMD)
- b) "**Financial Bid**": This will contain the complete financial bidding document with duly filled in Schedule of Financial Quote of Financial Bid & Tender Drawings.

The Bids without signature of the authorized person of bidder and seal, Without EMD, with conditions or conditional rebates shall be summarily rejected.

### **4. EVALUATION OF BID:**

- 4.1. **EVALUATION OF TECHNICAL BID:** The bids received will first be first opened and will be examined for Tender Fee, EMD Eligibility Criteria, Conditions, etc. Conditional Tenders and Tenders without EMD shall be summarily rejected.
- 4.2. **EVALUATION OF FINANCIAL BID:** The Financial Bid should contain the complete financial bid document with duly filled in Schedule of Financial Quote of Financial Bid and signed Tender drawings. Financial Bids of Technically qualified Bidders will only be opened. Work will be awarded to lowest bidder (L1) based on their quotes after making necessary arithmetical checks.

### **5. SCOPE & OBJECTIVE**

The Objective of the tender is to **Construction of Roof Covering Shed for Beam Hall at Plot-B, TIFR, Survey No. 36/P, Gopanpally (Village), Serilingampally (Mandal), Ranga Reddy Dist., Hyderabad – 500 046** as per the specifications and Bill of quantities mentioned in the Financial Bid.

**Period of Completion of Work: 180** days from the date of issue of work order



**Defect Liability Period: 12 months** from the date of handing over of completed structure as per tender.

**6. PAYMENT SCHEDULE:**

The contractor shall submit the bills for payments along with a detailed statement showing the actual works carried out under different heads of items in the format specified by the TIFR. Minimum value of the work for interim payment (3 Running Bills) shall be Rs.40,00,000/-. All interim and final bills will be settled based on the joint measurements of each item of works and certified by TIFR Engineer. The TIFR Officers may sanction the secured advance up to an amount not exceeding 90% of the value of the materials as assessed by the Engineer-in-charge, or an amount not exceeding 90% of the material element cost in the tendered rate of the finished item of work, whichever is lower on production of sufficient documentary evidence i.e. Original invoice, inventory, Insurance for the fire and theft etc. All interim bills will be paid within 15 days from the date of submission and Final Bill will be settled within 30 days from the date of submission with certification of TIFR Engineer.



<b>SECTION-II</b>	<b>ELIGIBILITY CRITERIA FOR TENDER QUALIFICATION</b>
-------------------	--

**A. Eligibility Criteria for Tender Qualification:**

1. The Agencies/Contractors will be qualified for **Construction of Roof Covering Shed for Beam Hall** at Plot-B, TIFR, Survey No. 36/P, Gopanpally Village, SerilingampallyMandal, Ranga Reddy District, Hyderabad under following eligibility criteria.

● **Eligibility criteria:**

1. Proof of registration with Government / Semi Government organizations like CPWD, MES, BSNL, Railways, State PWDs etc. in appropriate class OR having experience in execution of similar nature of works.

2. The applicant should have satisfactorily completed the works as mentioned below during the last **seven years ending previous day of last date of submission of tenders.**

i. One similar works each costing not less than Rs.114.57 Lakh

or

ii. Two similar works each costing not less than Rs.85.93 lakh

or

iii. Three work similar costing not less than Rs.57.28 lakh

**Important Notes:**

a) **Similar work shall mean: - Construction of Civil Sub Structure for steel framed structure including erection of foundation of bolt and fabrication, erection of steel frame structure with deck sheeting flooring system.**

b) Cost of work shall mean gross value of the completed work including the cost of materials supplied by the Client, but excluding those supplied free of cost. This should be certified by an officer not below the rank of Executive Engineer/Project Manager or equivalent.

3. The applicant should have had Average Annual financial turn over (gross) of **Rs.71.60 lakh** on construction works during immediate last three consecutive financial years ending **31st March 2023**. This should be duly audited by a Chartered Accountant. Year in which no turnover is shown would also be considered for working out the average.

4. The applicant **should not have incurred any loss** in more than two years during the last five consecutive immediate financial years ending **31st March 2023** duly certified by the licensed Chartered Accountant.

5. The applicant should have **Solvency of Rs.57.28 lakh** issued by a national bank within last one year from the date of tender notice.

6. The applicant's performance for each work completed in the last seven years should be certified by an officer not below the rank of Executive Engineer or equivalent.

7. Information and Instructions for tenderers posted on website shall part of tender document.
8. The tender document consisting of plans, specifications, the schedule of quantities of various types of items to be executed and the set of terms and conditions of the contract to be complied with and other necessary documents can be seen and downloaded from website CPP site <https://eprocure.gov.in/eprocure/app> or <https://www.tifrh.res.in/index.php/commercial-tenders/> free of cost.

**It is the responsibility of the tenderer to submit the EMD (hard copy) duly sealed and signed in the “Head- Technical Services, TIFR, Survey No. 36/P, Gopanpally (Village), Serilingampally (Mandal), Ranga Reddy Dist, Hyderabad-500046.” on or before prescribed time & date of submission.**

**Please check Annexure-V (Page No.163) for documents to be enclosed.**

**Note:**

- ❖ Agencies/Contractors should have a full-fledged in-house project management team to undertake the jobs.
- ❖ The Agencies/Contractors shall **strictly furnish** aforesaid information in the formats/schedules given. **Non adherence to furnishing of information in the given format/schedules given will lead to disqualification of tender.**
- ❖ Instructions to Agencies/Contractors for furnishing the information is given as under:
  - Each page of the application shall be signed by a person having necessary authority to do so.
  - If the space in the proforma is insufficient for furnishing full details, such information maybe given in separate sheets.
  - Applicants are required to furnish information against each item of the application. In case a certain item is not applicable, please write NA. Application containing incorrect and or inadequate information is liable to be rejected.
  - For any further clarification, The applicant may contact Tata Institute of Fundamental Research, Survey No. 36/P, Gopanpally Junction, Post: Gopanpally, Serilingampally, Hyderabad — 500 046.



**SCHEDULE – A**  
**BASIC INFORMATION**

1. Name of the firm :
2. a) Address :
- b) Telephone / Fax No. :
- c) Mobile No. Contact Person :
- d) PAN No. :
- e) GST Registration No. :
- f) Labour License Details :
- g) Branch Office if any in Hyderabad :
3. Type of Organization (Proprietorships / Partnership) Ltd. Co. / Co-Operative) (Copy of relevant document to be enclosed) :
4. Date of Incorporation :
5. Nature of Business :
6. Experience as prime Agencies/ Contractors (in Yrs.) :
7. Name and address of Bankers :
8. Organization chart of the Company including names and positions of directors / key personnel :

Signature of the Applicant(S)



**SCHEDULE – B**

**Major Civil Works (Copies of the completion certificate to be enclosed)**

A. Similar work of costing Rs.114.57 lakhs or two similar works of costing Rs.85.93 lakhs or 3 similar works of costing Rs.57.28 lakhs during last 7 financial years ended on date of publishing the tender for Research Institutes, Universities, Private Laboratories, R & D institutes, etc.

Sr.No	Name of the project & Address	Description of work in brief	Name of the Engineer	Name of the client also indicate whether Govt or semi Govt or Pvt body with full postal address	Contract Amount in Rs.	Year of commencement	Date of Completion		Whether work was left /uncompleted or the contract was terminated from either side? Give Details.	Any other relevant information
							Stipulated	Actual		
1.										
2.										

B. List of works in progress above Rs.54.38 lakhs

Sr No.	Name of the project & Address	Description of work in brief	Name of the Engineer with full postal address.	Name of the Client. Also indicate whether Govt. or semi Govt. or Pvt. Body with full postal address	Contract Amount in (Rs.)	Date of Completion	Present stage of work with reasons if the work is getting delayed	Any other relevant information
1.								
2.								

Signature of the Applicant (s)

Contractor's Signature with Stamp



**SCHEDULE – C**

**TECHNICAL PERSONNEL & SPECIAL EXPERIENCE**

1. List of technical personnel in your establishment giving details about their technical qualification and experience

Sr No.	Name	Age	Qualifications	Project Experience	Nature of works handled	Name of the project Handled	Date from which employed in your organization	Indicate special experience in Internal Electrification Installation & Testing projects in which were employed
1								
2								

2. Indicate other points if any to show your technical and managerial competency to indicate any important point in your favour.

Signature of the Applicant (s)

**SCHEDULE – D**

**FINANCIAL POSITION AND WORKING RESULTS**

	2020-21	2021-22	2022-23
1. Annual turnover	:	Rs.	
2. Net Profit	:	Rs.	
3. Credit Facilities from the Bank	:	Rs.	
a) Cash Credit	:	Rs.	
b) Overdraft Limit	:	Rs.	
c) Guarantee	:	Rs.	
d) Others	:	Rs.	
4. Certificate from the Bankers regarding financial soundness of the applicant	:	Enclosed (Yes / No)	
5. Solvency Certificate from the Bankers	:	Enclosed (Yes / No)	

Signature of the Application (s)

**SCHEDULE – E**

**MISCELLANEOUS INFORMATION**

- 1 Whether it would be possible to process Bank Guarantee for various advances during execution of the work. :
  
- 2 Details of Civil Suits / Litigations arised during execution of the contracts in the last 5 years. :
  
- 3 Latest Income Tax Clearance Certificate :
  
- 4 Name of the two senior official of Organizations preferably Govt./Semi Govt./ Autonomous/ Public Sector Organization for whom you have executed important and major works, who may be directly contracted by TIFR to gather information about your ability, competence and capacity of your work/organization/etc. :
  
- 5 Number of Supplementary sheets attached. :

Signature of the Applicant (s)



**SECTION-III**

**NOTICE & INSTRUCTIONS**

1. **Sealed item rate tenders** in the prescribed form are invited from Head-Technical Services, Tata Institute of Fundamental Research, Centre for Interdisciplinary Services, Hyderabad, for the following:

<b>Tender Notice No.</b>	<b>TIFR/PD/CF23-116/230997</b>
<b>Name of Work</b>	<b>Construction of Roof Covering Shed for Beam Hall at Plot-B, TIFR, Survey No. 36/P, Gopanpally (Village), Serilingampally (Mandal), Ranga Reddy Dist., Hyderabad-500046.</b>
<b>Estimated Cost</b>	<b>Rs.1,43,21,812/-</b>
<b>Time Limit</b>	<b>180 days (Completion Period)</b>
<b>Earnest Money Deposit</b>	<b>Rs.2,86,450 /- (Demand Draft to be drawn in favour of “Tata Institute of Fundamental Research”, Payable at Hyderabad (To be enclosed with the Technical Bid Part – I))</b>
<b>Tender Fee</b>	<b>Rs.1000/- (Rupees Five Hundred only)</b>
<b>Last Date &amp; Time of Submission of Tender</b>	<b>15.11.2023 by 13:00 Hrs</b>
<b>Date &amp; Time of Opening of Technical Bid</b>	<b>15.11.2023 at 15:00 Hrs</b>

2. **Sale of Tender:** Can be purchased from TATA INSTITUTE OF FUNDAMENTAL RESEARCH (TIFR), SERVICE BUILDING 1, SURVEY NO. 36/P, GOPANPALLY JN, POST: GOPANPALLY, HYDERABAD — 500 046, on payment of tender cost in the form of **Demand Draft to be drawn in favour of “Tata Institute of Fundamental Research”, Payable at Hyderabad (To be enclosed with the Technical Bid part – I).**

The tender documents issued must accompany at the time of submission, proof of the tender cost already paid

3. **Submission of Tender & Opening:** Tenders shall be submitted in a sealed envelope super scribed with Tender enquiry No., Due Date and with heading as **Construction of Roof Covering Shed for Beam Hall at Plot-B, TIFR, Survey No. 36/P, Gopanpally (Village), Serilingampally (Mandal), Ranga Reddy Dist., Hyderabad-500 046”** containing two separate sealed covers clearly super scribed as “TECHNICAL BID” and “FINANCIAL BID” on or before the closing date and time of submission in the following manner:

**“TECHNICAL BID”**: This will contain the following:

- a) Proof of Tender Cost paid already
- b) EMD
- c) Schedules giving information on Eligibility Criteria specified for tender qualification.

**“FINANCIAL BID”**: **Signed copy of the Financial Bid quoting amount in the stipulated format and signed copies of the tender drawings.**

**4. Earnest Money Deposit (EMD)**: EMD shall be submitted in the form of **Demand Draft to be drawn in favour of “Tata Institute of Fundamental Research”, Payable at Hyderabad (To be enclosed with the Technical Bid Part-I)**

Earnest Money Deposit (EMD): Every Bidder has to pay EMD of amount as specified elsewhere in this tender by Demand Draft in favour of **“Tata Institute of Fundamental Research”** along with the offer. Quotation received without EMD shall be rejected and no correspondence whatsoever will be entertained. For successful bidder the EMD will be adjusted against Performance Guarantee and will be refunded after completion of work /supply of material at site and for unsuccessful bidders EMD will be refunded after placing the order to successful bidder.

**5. Performance guarantee**: The tenderer, whose tender is accepted, will be required to furnish a performance guarantee of 2.5% of the tendered amount within 7 (seven) working days from the date of intimation. This guarantee shall be in the form Demand Draft / Pay Order / Banker’s cheque / Deposit or Government Securities / Fixed Deposit Receipt (FDR) or Guarantee Bonds (BG) of any Scheduled Bank in accordance with the form as Annexure – III here to. In case a fixed deposit receipt of any Bank is furnished by the contractor to TIFR as part of the performance guarantee and the Bank is unable to make payment against the said fixed deposit receipt, the loss caused thereby shall fall on the contractor and the contractor shall forthwith on demand furnish additional security to TIFR to make good the deficit.

The Performance Guarantee shall be initially valid up to the stipulated date of completion **plus 60 days** beyond that. In case the time for completion of work gets enlarged, the contractor shall get the validity of performance Guarantee extended to cover such enlarged time for completion of work. The performance guarantee shall be returned to the contractor, without any interest, after recording of the completion certificate for the work by the competent authority.

The Engineer-in-charge shall make a claim under the Performance guarantee for amounts to which TIFR entitled under the contract (notwithstanding and / or without prejudice to any other provisions in the contract agreement) in the event of:

- a) Failure by the contractor to extend the validity of the Performance Guarantee as described herein above, in which event the Engineer-in-charge may claim the full amount of the Performance guarantee.
- b) Failure by the contractor to pay TIFR, Hyderabad any amount due, either as agreed by the contractor or determined under any of the Clauses / Conditions of the agreement, within 30 days of the service of notice to this effect by Engineer-in-charge.

In the event of the contract being determined under provisions of any of the relevant clauses of the agreement, the performance guarantee shall stand forfeited in full and shall be absolutely at the disposal of TIFR, Hyderabad.

- 6. Security Deposit:** The tenderer, whose tender is accepted, will also be required to furnish by way of Security Deposit for fulfillment of his contract, an amount equal to 5% of the tendered value of the work. Earnest Money deposited at the time of tenders will be treated as part of the Security Deposit.

or

The successful tenderer shall permit TIFR, Hyderabad at the time of making any payment to him for work done under the contract to deduct a sum at the rate of 5% of the gross amount of each running bill till the sum along with the sum already deposited as earnest money, will amount to security deposit of 5% of the tendered value of the work. Such deductions will be made and held by TIFR by way of Security Deposit unless he has / they have deposited the amount of Security at the rate mentioned above in cash or in the form of Fixed Deposit Receipts.

In case a fixed deposit receipt of any bank is furnished by the contractor to TIFR, Hyderabad as part of the security deposit and the bank is unable to make payment against the said fixed deposit receipt, the loss caused thereby shall fall on the contractor and the contractor shall forthwith on demand furnish additional security to TIFR, Hyderabad to make good the deficit.

All compensation or the other sums of money payable by the contractor under the terms of this contract may be deducted from, or paid by the sale of a sufficient part of his security deposit or from the interest arising there from, or from any sums which may be due to or may become due to the contractor by TIFR or any account whatsoever and in the event of his Security Deposit being reduced by reason of any such deductions or sale as aforesaid, the contractor shall within 10 days make good in cash or fixed deposit receipt tendered by the State Bank of India or by scheduled banks (if deposited for more than 12 months) endorsed in favour of the TIFR, HYDERABAD, any sum or sums which may have been deducted from, or raised by sale of his security deposit or any part thereof.

Security Deposit shall be initially valid up to the one year from the date of completion of work. In case the time for completion of work gets enlarged, the contractor shall get the validity of Security Deposit extended to cover such enlarged time for completion of work. The Security Deposit shall be returned to the contractor, without any interest, after completion of defect liability period.

Security Deposit as deducted above can be released against Bank Guarantee issued by a Scheduled Bank on its accumulation to a minimum of Rs.5 Lakhs subject to the condition that amount of such Bank Guarantee, except last one, shall not be less than Rs.5 Lakhs. Bank Guarantee should be submitted which will be valid upto the expiry of defect liability period.

- 7. Acceptance of Tender:** The competent authority, on behalf of TIFR, Hyderabad does not bind itself to accept the lowest or any other tender, and reserves to himself the authority to reject any or all the tenders received, without assignment of any reason. All tenders, in which any of the prescribed conditions is not fulfilled or any condition, including that of conditional rebates, is put forth by the tenderer, shall be summarily rejected.

The Competent Authority, on behalf of TIFR, Hyderabad reserves to itself the right of accepting the whole or any part of the tender and the tenderer shall be bound to perform the same at the rates quoted. The officer inviting tenders shall have the right of rejecting all or any of the tenders and will not be bound to accept the lowest tender or any other tender.

**8. Validity of Tender:** The tender for the work shall remain open for acceptance for a period of 75 days from the last date of submission of tenders. If any tenderer withdraws his tender before the said period, or before issue of Letter of Intent, whichever is earlier, or makes any modifications in the terms and conditions of the tender which are not acceptable to the Department, then TIFR, Hyderabad shall, without prejudice to any other right or remedy, be at liberty to forfeit 50% of the said earnest money absolutely. Further the tenderer shall not be allowed to participate in the retendering process of the work.

**9. Levy / Taxes payable by contractor:**

- i. GST or any other tax on materials and services in respect of this contract shall be payable by the contractor and TIFR shall not entertain any claim whatsoever in this respect.
- ii. The contractor shall deposit royalty and obtain necessary permit as required for supply of the sand, aggregate, stone etc. from local authorities.

**10. Deduction of Income Tax:** Applicable as per IT Rules.

**11. Site visit by the tenderer before tendering:** Tenderers are advised to inspect and examine the site and its surroundings during working hours and satisfy themselves before submitting their tenders as to the nature of the ground and sub-soil (so far as is practicable), the form and nature of the site, the means of access to the site, the accommodation they may require and in general shall themselves obtain all necessary information as to risks, contingencies and other circumstances which may influence or affect their tender. A tenderer shall be deemed to have full knowledge of the site whether he inspects it or not and no extra charges consequent on any misunderstanding or otherwise shall be allowed.

**12. Signing of Tender and receipts for payments:** In the event of the tender being submitted by a firm, it must be signed separately by each partner thereof or in the event of the absence of any partner, it must be signed on his behalf by a person holding a power-of-attorney authorizing him to do so, such power of attorney to be produced with the tender, and it must disclose that the firm is duly registered under the Indian Partnership Act-1952. Receipts for payments made on account of work, when executed by a firm, must also be signed by all the partners, except where contractors are described in their tender as a firm, in which case the receipts must be signed in the name of the firm by one of the partners, or by some other person having due authority to give effectual receipts for the firm.

**13. Tenderer's responsibilities:** The tenderer shall be responsible for arranging and maintaining at his own cost all materials, tools & plants, facilities for workers and all other services required for executing the work unless otherwise specifically provided for in the contract documents. Submission of a tender by a tenderer implies that they have read this notice & all other contract documents, and has made himself aware of the scope & specifications of the work

to be done and local conditions and factors having a bearing on the execution of the work.

- 14. Signing of contract:** The Notice Inviting Tender shall form a part of the contract document. The successful tenderer / contractor, on acceptance of his tender by the Accepting Authority, shall, within 15 days from the stipulated date of start of the work, sign the contract consisting of: the Notice Inviting Tender, all the documents including all conditions, specifications and drawings, if any, forms the tender as issued at the time of invitation of tender and acceptance thereof together with any correspondence leading thereto.
- 15. Canvassing:** either directly or indirectly, in connection with the tenders is strictly prohibited and the tenders submitted by the contractors who resort to canvassing will be liable to rejection and may be barred from future participation in TIFR works.



**UNDERTAKING BY THE TENDERER**

I / We have read and examined the Tender document including terms & conditions, specifications, bill of quantities, drawings and designs, general rules & directions, General Conditions of Contract, Special Conditions of Contract and all relevant other documents, publications and rules referred to in the Conditions of Contract and all other contents in the tender documents for the work.

I / We, hereby tender for execution of the work specified for the TIFR, Hyderabad within the time specified and in accordance in all respects with the specifications, designs, drawings and instructions in writing.

We agree to keep the tender open for **Seventy Five (75) days** from the last date of its submission and not to make any modifications in its terms and conditions. A sum of Rs ..... has been deposited in cash / receipt treasury challan / deposit at call receipt of scheduled bank / fixed deposit receipt of scheduled bank / demand draft of a scheduled bank / Bank Guarantee issued by a Scheduled Bank as earnest money. If I / we, fail to furnish the prescribed performance guarantee within prescribed period, I / we agree that the said TIFR, Hyderabad or its authorized officer shall without prejudice to any other right or remedy, be at liberty to forfeit the said earnest money absolutely. Further, if I / we fail to commence work as specified, I / we agree that the TIFR, Hyderabad shall without prejudice to any other right or remedy available in law, be at liberty to forfeit the said earnest money and the performance guarantee absolutely, otherwise the said earnest money shall be retained by TIFR, Hyderabad towards security deposit to execute all the works referred to in the tender documents upon the terms and conditions contained or referred to therein.

Further, I / We agree that in case of forfeiture of earnest money or both Earnest Money & Performance Guarantee as aforesaid, I / We shall be debarred for participation in the re-tendering process of the work.

I / We hereby declare that I / We shall treat the tender documents, drawings and other records connected with the work as secret / confidential documents and shall not communicate information derived there-from to any person other than a person to whom I / We am / are authorized to communicate the same or use the information in any manner prejudicial to the safety of the State.

**Seal & Signature of Contractor**  
**Postal Address**

**Dated**

**Witness**

**Address**

**Occupation**

Contractor's Signature with Stamp

<b>SECTION-IV</b>	<b>GENERAL INFORMATION</b>
-------------------	----------------------------

**i). Definition of Terms:**

- a) The '**Contract**' means the documents forming the tender and acceptance thereof and the formal agreement executed between the Competent authority on behalf of the TIFR, Hyderabad and the Contractor together with the documents referred to therein including these conditions, the specifications, designs, drawings and instructions issued from time to time by the Engineer-in-charge and all these documents taken together, shall be deemed to form one contract and shall be complementary to one another.
- b) The expression '**Works**' or '**Work**' shall, unless there be something either in the subject or context repugnant to such construction, be construed and taken to mean the works by or by virtue of the contract contracted to be executed whether temporary or permanent and whether original, altered, substituted or additional.
- c) The '**Site**' shall mean the land or other places on, into or through which work is to be executed under the contract or any adjacent land, path or street through which work is to be executed under the contract or any adjacent land, path or street which may be allotted or used for the purpose of carrying out the contract.
- d) The '**Contractor**' shall mean the individual, firm or company, whether incorporated or not, undertaking the works and shall include the legal personnel representative of such individual or the persons composing such firm or company or the successors of such firm or company and the permitted assignees of such individual, firm or company.
- e) The '**Engineer-in-Charge**' means the Engineer / Officer, who shall supervise and be in charge of the work on behalf of TIFR, Hyderabad.
- f) '**Temporary Work**' means all temporary works of every kind required in or about the execution, completion and maintenance of the works.
- g) '**Market Rate**' shall be the rate as decided by the Engineer-in-Charge on the basis of the cost of materials and labour at the site where the work is to be executed plus 15% to cover, all overheads and profits. h) '**TIFR**' means TIFR, Hyderabad.
- h) '**Tendered value**' means the value of the entire work as stipulated in the letter of award.
- i) '**Time Limit**': The time allowed for carrying out the work reckoned from 10th day of the date of issue of work order.

**ii). Opening of Tenders: Tenders shall be opened by the authorized committee of TIFR in the Presence of intending bidders or their authorized representatives at the scheduled date and time.**

**iii.) Declaration by tenderer:** The tenderers shall sign a declaration under the Official Secret Act-1923 for maintaining secrecy of the tender documents, drawings or other records connected with the work given to them. The unsuccessful tenderers shall return all the drawings given to them.

**iv.) Filling up of rates:** All rates shall be quoted on the tender form by the tenderers in figures and

words, and the amount in figures only. All rates shall be quoted on the prescribed tender form. The amount for each item should be worked out and requisite totals given.

- a. The rate(s) must be quoted in decimal coinage. Amounts must be quoted in full rupees by ignoring fifty paise and considering more than fifty paise as rupee one.
- b. If a discrepancy is found, the rates which correspond with the amount worked out by the contractor shall, unless otherwise proved, be taken as correct.
- c. If the amount of an item is not worked out by the tenderer, or it does not correspond with the rate written either in figures or in words, then the rates quoted by the tenderer in words shall be taken as correct.
- d. Where the rate quoted by the tenderer in figures and in words tally but the amount is not worked out correctly, the rate quoted by the tenderer will, unless otherwise proved, be taken as correct and not the amount.
- e. In event no rate has been quoted for any item(s), leaving space both in figure(s), word(s), and amount blank, it will be presumed that the contractor has included the cost of this / these item(s) in other items and rate for such item(s) will be considered as **zero** and work will be required to be executed accordingly.
- v. **Quoted rates to include all taxes:** GST in respect of this contract shall be payable by the contractor and TIFR will not entertain any claim whatsoever in respect of the same. GST rule will be applicable if any with effect from 01.07.2017 as per GST regime. The applicable TDS/ other charges if any as per GST rule will be deducted. TIFR Hyderabad GST no.36AAATT3951F2ZG.
- vi. **Action in case of un realistic rates:** In the case of any tender where unit rate of any item(s) appear unrealistic, such tender will be considered as unbalanced and in case the tenderer is unable to provide satisfactory explanation, such a tender is liable to be disqualified and rejected.
- vii. **Contractor to depute his representative at site:** The successful tenderer for the work should have responsible and responsive representative with adequate powers to take speedy decisions during the entire period of execution at the Work place. On acceptance of the tender, the name of the accredited representative(s) of the contractor, who would be responsible for taking instructions from the Engineer-in-Charge, shall be communicated in writing to the Engineer-in-Charge.
- viii. **Sufficiency of Tender:** The Contractor shall be deemed to have satisfied himself before tendering as to the correctness and sufficiency of his tender for the works and of the rates and prices quoted in the Bill of Quantities, at which rates and prices shall, except as otherwise provided, cover all his obligations under the Contract and all matters and things necessary for the proper completion and maintenance of the works.
- ix. **Signing of Contract:** The successful tenderer / contractor, on acceptance of his tender by the Accepting Authority, shall, within 15 days from the stipulated date of start of the work, sign the contract consisting of complete tender document including conditions, bill of quantities, drawings, if any, and acceptance thereof together with any correspondence leading thereto along with DAE Safety Code and Model Rules for the protection of health, sanitary arrangements for workers employed by DAE or its contractors, DAE Contractor's Labour Regulations, List of Acts and omissions for which fines can be imposed. No payment for the work done will be made unless contract is signed by the contractor.



**SECTION-V**

**GENERAL CONDITIONS**

1. **Compensation for delay:** If the contractor fails to maintain the required progress in terms of contract or to complete the work and clear the site on or before the stipulated or extended date of completion, he shall, without prejudice to any other right or remedy available under the Law to the Govt. on account of such breach, pay as agreed compensation the amount calculated at **1.5% per month of delay to be computed on per day basis** on the amount of tendered value of the work for every completed day / month (as applicable) that the progress remains below that specified or that the work remains incomplete. Provided always that the total amount of compensation for delay to be paid under this condition shall not exceed 10% of the tendered value of work or of the tendered value of the item or group of items of work for which a separate period of completion is originally given.
2. **Determination of contract:** Subject to other provisions contained in this clause, the Engineer-in-Charge may, without prejudice to his any other right or remedy against the contractor in respect of any delay, inferior workmanship, any claim for damages and /or any other provisions of this contract or otherwise, and whether the date for completion has or has not elapsed, by notice in writing absolutely determine the contract in any of the following cases:
  - i. if the contractor having been given by the Engineer-in-Charge a notice in writing to rectify, reconstruct or replace any defective work or that the work is being performed in an inefficient or otherwise improper or un workman-like manner shall omit to comply with the requirements of such notice for a period of 7 days thereafter.
  - ii. If the contractor has, without reasonable cause, suspended the progress of the work or has failed to proceed with the work with due diligence so that in the opinion of the Engineer-in-Charge (which shall be final and binding) he will be unable to secure completion of the work by the date for completion and continue to do so after a notice in writing of 7 days from the Engineer-in-charge.
  - iii. If the contractor fails to complete the work within the stipulated date or items of work with individual date of completion, if any stipulated, on or before such date(s) of completion and does not complete them within the period specified in a notice given in writing in that behalf by the Engineer-in-Charge.
  - iv. If the contractor persistently neglects to carry out his obligations under the contract and / or commits default in complying with any of the terms and conditions of the contract and does not remedy it or take effective steps to remedy it within 7 days after a notice in writing is given to him in that behalf by the Engineer-in-Charge.
  - v. If the contractor shall offer or give or agree to give to any person in TIFR or to any other person on his behalf any gift or consideration of any kind as an inducement or reward for doing or forbearing to do or for having done or forborne to do any act in relation to the obtaining or execution of this or any other contract for TIFR.
  - vi. If the contractor shall obtain a contract elsewhere as a result of wrong tendering or other non-bonafide methods of competitive tendering.
  - vii. If the contractor assigns, transfers, sublets (engagement of labour on a piece-work basis or of labour with materials not to be incorporated in the work, shall not be deemed to be subletting) or otherwise parts with or attempts to assign, transfer, sublet or otherwise parts with the entire works or any portion thereof without the prior written approval of the Engineer-in-Charge.

- 
- viii. If the work is not started by the contractor within 1 / 8th of the stipulated time.
- ix. When the contractor has made himself liable for action under any of the cases aforesaid, the Engineer-in- Charge on behalf of the TIFR, Hyderabad shall have powers:
- a) To determine the contract as aforesaid (of which termination notice in writing to the contractor under the hand of the Engineer-in-Charge shall be conclusive evidence). Upon such determination, the Earnest Money Deposit, Security Deposit already recovered and Performance guarantee/Security Deposit under the contract, shall be liable to be forfeited, and shall be absolutely at the disposal of TIFR, Hyderabad.
  - b) After giving notice to the contractor to measure up the work of the contractor and to take such whole, or the balance or part thereof, as shall be unexecuted out of his hands and to give it to another contractor to complete the work. The contractor, whose contract is determined as above, shall not be allowed to participate in the tendering process for the balance work.
- x. In the event of above courses being adopted by the Engineer-in-Charge, the contractor shall have no claim to compensation for any loss sustained by him by reason of his having purchased or procured any materials or entered into any engagements or made any advances on account or with a view to the execution of the work or the performance of the contract. And in case action is taken under any of the provisions aforesaid, the contractor shall not be entitled to recover or be paid any sum for any work thereof or actually performed under this contract unless and until the Engineer-in-Charge has certified in writing the performance of such work and the value payable in respect thereof and he shall only be entitled to be paid the value so certified.
- 3. Contractor liable to pay compensation even if contract is not determined:** In any case in which any of the powers conferred upon the Engineer-in-Charge under the contract, shall have become exercisable and the same are not exercised, the non-exercise thereof shall not constitute a waiver of any of the conditions hereof and such powers shall notwithstanding be exercisable in the event of any future case of default by the contractor and the liability of the contractor for compensation shall remain unaffected. In the event of the Engineer-in-Charge putting in force all or any of the powers vested in him under the preceding clause he may, if he so desires after giving a notice in writing to the contractor, take possession of (or at the sole discretion of the Engineer-in-Charge which shall be final and binding on the contractor), use as on hire (the amount of the hire money being also in the final determination of the Engineer-in-Charge) all or any tools, plant, materials and stores, in or upon the works, or the site thereof, belonging to the contractor, or procured by the contractor and intended to be used for the execution of the work / or any part thereof, paying or allowing for the same in account at the contract rates, or, in the case of these not being applicable, at current market rates to be certified by the Engineer-in-Charge, whose certificate thereof shall be final and binding on the contractor, his clerk of the works, foreman or other authorized agent to remove such tools, plant, materials, or stores from the premises (within a time to be specified in such notice); in the event of the contractor failing to comply with any such requisition, the Engineer-in-Charge may remove them at the contractor's expense or sell them by auction or private sale on account of the contractor and at his risk in all respects and the certificate of the Engineer-in-Charge as to the expenses of any such removal and the amount of the proceeds and expenses of any such sale shall be final and conclusive against the contractor.

- 4. Time Extension for delay:** The time allowed for execution of the works as stipulated in the contract or the extended time in accordance with these conditions shall be the essence of the Contract. The execution of the works shall commence from such time period as mentioned in contract. If the Contractor commits default in commencing the execution of the work as aforesaid, TIFR shall without prejudice to any other right or remedy available in law, be at liberty to forfeit the earnest money & Performance guarantee/Security Deposit absolutely.

As soon as possible after the Contract is signed, the Contractor shall submit a Time and Progress Chart for each mile stone and get it approved by the Department. The Chart shall be prepared in direct relation to the time stated in the Contract documents for completion of items of the works. It shall indicate the forecast of the dates of commencement and completion of various trades of sections of the work and may be amended as necessary by agreement between the Engineer-in-Charge and the Contractor within the limitations of time imposed in the Contract documents, and further to ensure good progress during the execution of the work, the contractor shall in all cases in which the time allowed for any work, exceeds one month (save for special jobs for which a separate programme has been agreed upon) to complete the work as per the mile stones given.

**If the work(s) be delayed by:**

- i. Force majeure, or
- ii. Abnormally bad weather, or
- iii. Serious loss or damage by fire, or
- iv. Civil commotion, local commotion of workmen, strike or lockout, affecting any of the trades employed on the work, or
- v. Delay on the part of other contractors or tradesmen engaged by Engineer-in-Charge in executing work not forming part of the Contract, or
- vi. Any other cause which, in the absolute discretion of the Engineer-in-Charge is beyond the Contractor's control, then upon the happening of any such event causing delay, the Contractor shall immediately give notice thereof in writing to the Engineer-in-Charge but shall nevertheless use constantly his best endeavors to prevent or make good the delay and shall do all that may be reasonably required to the satisfaction of the Engineer-in-Charge to proceed with the works.

Request for rescheduling of Mile stones and extension of time, to be eligible for consideration, shall be made by the Contractor in writing within 14 days of the happening of the event causing delay on the prescribed form. The Contractor may also, if practicable, indicate in such a request the period for which extension is desired. In any such case the **Engineer-in-Charge** may give a fair and reasonable extension of time and reschedule the mile stones for completion of work. Such extension shall be communicated to the Contractor by the Engineer-in-Charge in writing, within 3 months of the date of receipt of such request. Non application by the contractor for extension of time shall not be a bar for giving a fair and reasonable extension by the Engineer-in-Charge and this shall be binding on the contractor.

- 5. Measurements of work done:** Engineer-in-Charge shall, except as otherwise provided, ascertain and determine by measurement, the value in accordance with the contract of work done. All measurement of all items having financial value shall be entered in Measurement Book and/or level field book so that a complete record is obtained of all works performed under the contract. All measurements and levels shall be taken jointly by the Engineer-in-Charge or his authorized representative and by the contractor or his authorized representative from time to time during the progress of the work and such measurements shall be signed and dated by the Engineer-in-Charge and the contractor or their representatives in token of their acceptance. If the contractor

objects to any of the measurements recorded, a note shall be made to that effect with reason and signed by both the parties. If for any reason the contractor or his authorized representative is not available and the work of recording measurements is suspended by the Engineer-in-Charge or his representative, the Engineer-in-Charge and the Department shall not entertain any claim from contractor for any loss or damages on this account. If the contractor or his authorized representative does not remain present at the time of such measurements after the contractor or his authorized representative has been given a notice in writing three (3) days in advance or fails to countersign or to record objection within a week from the date of the measurement, then such measurements recorded in his absence by the Engineer-in-Charge or his representative shall be deemed to be accepted by the Contractor.

The contractor shall, without extra charge, provide all assistance with every appliance, labour and other things necessary for measurements and recording levels. Except where any general or detailed description of the work expressly shows to the contrary, measurements shall be taken in accordance with the procedure set forth in the specifications notwithstanding any provision in the relevant Standard Method of measurement or any general or local custom. In the case of items which are not covered by specifications, measurements shall be taken in accordance with the relevant standard method of measurement issued by the Bureau of Indian Standards and if for any item no such standard is available, then a mutually agreed method shall be followed.

The contractor shall give, not less than 7 days' notice to the Engineer-in-Charge or his authorized representative in-charge of the work, before covering up or otherwise placing beyond the reach of measurement any work in order that the same may be measured and correct dimensions thereof be taken before the same is covered up or placed beyond the reach of measurement and shall not cover up and place beyond reach of measurement any work without consent in writing of the Engineer-in-Charge or his authorized representative in-charge of the work who shall within the aforesaid period of seven days inspect the work, and if any work shall be covered up or placed beyond the reach of measurements without such notice having been given or the Engineer-in-Charge's consent being obtained in writing, the same shall be uncovered at the Contractor's expense, or in default thereof no payment or allowance shall be made for such work or the materials with which the same was executed.

Engineer-in-Charge or his authorized representative may cause either themselves or through another officer of the department to check the measurements recorded jointly or otherwise as aforesaid and all provisions stipulated herein above shall be applicable to such checking of measurements or levels. It is also a term of this contract that recording of measurements of any item of work in the measurement book and/or its payment in the interim, on account or final bill shall not be considered as conclusive evidence as to the sufficiency of any work or material to which it relates nor shall it relieve the contractor from liabilities from any over measurement or defects noticed till completion of the defects liability period.

- 6. Completion Certificate:** Within ten days of the completion of the work, the contractor shall give notice of such completion to the Engineer-in- Charge and within fifteen days of the receipt of such notice, the Engineer-in- Charge shall inspect the work, and if there is no defect in the work, shall furnish the contractor with a certificate of completion, otherwise a provisional certificate of physical completion indicating defects (a) to be rectified by the contractor and / or (b) for which payment will be made at reduced rates, shall be issued. But no final certificate of completion shall be issued, nor shall the work be considered to be complete until the contractor shall have removed from the premises on which the work shall be executed, all scaffolding, surplus materials, rubbish

and all huts and sanitary arrangements, required for his/their work people on the site in connection with the execution of the works as shall have been erected or constructed by the contractor(s) and cleaned off the dirt from all wood work, doors, windows, walls, floors or other parts the building, in, upon, or about which the work is to be executed or of which he may have had possession for the purpose of the execution thereof, and not until the work shall have been measured by the Engineer-in-Charge. If the contractor shall fail to comply with the requirements of this clause as to removal of scaffolding, surplus materials and rubbish and all huts and sanitary arrangements as aforesaid and cleaning off dirt on or before the date fixed for the completion of the work, the Engineer-in-Charge may at the expense of the contractor remove such scaffolding, surplus materials and rubbish, etc., and dispose off the same as he thinks fit and clean off such dirt as aforesaid; and the contractor shall have no claim in respect of scaffolding or surplus materials as aforesaid except for any sum actually realized by the sale thereof.

7. **Contractor to keep site clean:** When the annual repair and maintenance of works are carried out, the splashes and droppings from white washing, colour washing, painting etc. on wall, floors, doors, windows etc. shall be removed and the surface cleaned simultaneously with the completion of these items of work in the individual rooms, quarters or premises etc. where the work is done without waiting for the actual completion of all the other items of work in contract. In case the contractor fails to comply with the requirements of this clause, the Engineer-in-Charge shall have the right to get this work done at the cost of the contractor either departmentally or through any other agency. Before taking such action, the Engineer-in-Charge shall give **10 days'** notice in writing to the contractor.
8. **Completion plans to be submitted by the contractor:** The contractor shall submit completion plan required as per Specifications for **Construction of Civil Super Structure and Interior for National Center for Nutrition and metabolism at Plot B** as applicable within 7 days of the completion of the work. In case, the contractor fails to submit the completion plan as aforesaid, he shall be liable to pay a sum equivalent to 2.50% of the value of the work subject to a ceiling of Rs.15000/- as may be fixed by the Engineer-in-Charge and in this respect the decision of the Engineer-in-Charge shall be final and binding on the contractor.
9. **Payment of Running & Final Bill:** The contractor will be paid 3 Running Account (RA) Bills and Final Bill considering the progress of works based on measurement of works completed. The contractor shall submit the bills for payments along with detailed statement showing the actual works carried out under different heads of items in the format specified by TIFR-, Hyderabad. Minimum value of the work for interim payment shall be Rs.40,00,000 /-.

**BILL FORMAT**

Tender Item No.	Description of Items (as per Order)	Unit	Tender Quantity	Executed Quantity	Rate	% work done	Amount

NOTE: All quantities in the bill should be in cumulative.  
 All measurements should be in the order of tender sequence and should be recorded in the measurement book.  
 The Measurement should be strictly in the below mentioned format only.

**MEASUREMENT FORMAT**

Tender Item No.	Description of Item Location against each Measurement taken	Nos	Length	Breadth /width	Height	Qty.	Remarks

The works which have been certified for running bills will also be verified along with the final bill and any defects found need to be replaced / rectified by the contractor at his cost. Till the time, the site is handed over in full, it is the contractor’s liability to safeguard the works done and completed at site. The Progress of work should not be affected in any way quoting the reason of non-availability of funds / materials / releasing of running bill. The liability of contractor is to complete all works in his scope in the scheduled time as per the terms of contract and will not relieve the contractors from his obligations once the Running bill is paid / kept pending.

The Security Deposit, shall be refunded on expiry of the Defects Liability Period after rectifying all defects to the satisfaction of the TIFR-Hyderabad/E.I.C. The acceptance of payment of the final bill by the Contractor would indicate that he would have no further claim in respect of the work executed.

**10. Materials to be provided by the contractor:** The contractor shall, at his own expense, provide all materials, required for the works other than those specified otherwise. The contractor shall, at his own expense and without delay, supply to the Engineer-in-Charge samples of materials to be used on the work and shall get these approved in advance. All such materials to be provided by the Contractor shall be in conformity with the specifications laid down or referred to in the contract. The contractor shall, if requested by the Engineer-in- Charge furnish proof, to the satisfaction of the Engineer-in-Charge that the materials so comply. The Engineer-in- Charge shall within thirty days of supply of samples or within such further period as he may require intimate to the Contractor in writing whether samples are approved by him or not. If samples are not approved, the Contractor shall forthwith arrange to supply to the Engineer-in-Charge for his approval, fresh samples complying with the specifications laid down in the contract. When materials are required to be tested in accordance with specifications, approval of the Engineer-in-Charge shall be issued after the test results are received.

The Contractor shall at his risk and cost submit the samples of materials to be tested or analyzed and shall not make use of or incorporate in the work any materials represented by the samples until the required tests or analysis have been made and materials finally accepted by the Engineer-in-Charge. The Contractor shall not be eligible for any claim or compensation either arising out of any delay in the work or due to any corrective measures required to be taken on account of and as a result of testing of materials.

The contractor shall, at his risk and cost, make all arrangements and shall provide all facilities as the Engineer- in-Charge may require for collecting, and preparing the required number of samples for such tests at such time and to such place or places as may be directed by the Engineer-in-Charge and bear all charges and cost of testing unless specifically provided for otherwise elsewhere in the contract or specifications. The Engineer-in- Charge or his authorized representative shall at all times have access to the works and to all workshops and places where

work is being prepared or from where materials, manufactured articles or machinery are being obtained for the works and the contractor shall afford every facility and every assistance in obtaining the right to such access.

The Engineer-in-Charge shall have full powers to require the removal from the premises of all materials which in his opinion are not in accordance with the specifications and in case of default, the Engineer-in-Charge shall be at liberty to employ at the expense of the contractor, other persons to remove the same without being answerable or accountable for any loss or damage that may happen or arise to such materials. The Engineer-in-Charge shall also have full powers to require other proper materials to be substituted thereof and in case of default, the Engineer-in-Charge may cause the same to be supplied and all costs which may attend such removal and substitution shall be borne by the Contractor.

The contractor shall at his own expense, provide a material testing lab at the site for conducting routine field tests. The lab shall be equipped at least with the testing equipment as specified in the contract.

- 11. Excavated / dismantled material will be TIFR's property:** The contractor shall treat all materials obtained during dismantling of a structure, excavation of the site for a work etc. as TIFR property and such materials shall be disposed off to the best advantage of TIFR according to the instructions in writing issued by the Engineer-in-Charge.
- 12. Work to be executed in accordance with specifications, drawings, orders, etc. :** The contractor shall execute the whole and every part of the work in the most substantial and workman like manner both as regards materials and otherwise in every respect in strict accordance with the specifications. The contractor shall also conform exactly, fully and faithfully to the designs, drawings and instructions in writing in respect of the work signed by the Engineer-in-Charge. The several documents forming the Contract are to be taken as mutually explanatory of one another, detailed drawings being followed in preference to small scale drawing and figured dimensions in preference to scale.

The following order of preference shall be observed:

- a) Description of Bill of Quantities.
- b) Particular Specifications and Special Clauses, if any.
- c) Drawings.
- d) Department of Atomic Energy Specifications
- e) C.P.W.D. Specifications.
- f) Indian Standard Specifications of B.I.S.
- g) Manufacturer's specifications

The contractor shall comply with the provisions of the contract and with the care and diligence execute and maintain the works and provide all labour and materials, tools and plants including for measurements and supervision of all works, structural plans and other things of temporary or permanent nature required for such execution and maintenance in so far as the necessity for providing these, is specified or is reasonably inferred from the contract. The Contractor shall take full responsibility for adequacy, suitability and safety of all the works and methods of construction. The contractor shall comply with the provisions of the contract and with the care and diligence execute and maintain the works and provide all labour and materials, tools and plants including for measurements and supervision of all works, structural plans and other things of temporary or permanent nature required for such execution and maintenance in so far as the necessity for providing these, is specified or is reasonably inferred from the contract. The Contractor shall take full responsibility for adequacy, suitability and safety of all the works and methods of construction.

Contractor shall be required to submit a guarantee bond for all the water proofing works carried out by him. Contractor shall use the items of approved makes.

**13. Deviations / Variations : Extent And Pricing:** The Engineer-in-Charge shall have power (i) to make alteration in, omissions from, additions to, or substitutions for the original specifications, drawings, designs and instructions that may appear to him to be necessary or advisable during the progress of the work, and (ii) to omit a part of the works in case of non-availability of a portion of the site or for any other reasons and the contractor shall be bound to carry out the works in accordance with any instructions given to him in writing signed by the Engineer-in- Charge and such alterations, omissions, additions or substitutions shall form part of the contract as if originally provided therein and any altered, additional or substituted work which the contractor may be directed to do in the manner specified above as part of the works, shall be carried out by the contractor on the same conditions in all respects including price on which he agreed to do the main work except as hereafter provided.

**A. Deviation and Time Extension:** The time for completion of the works shall, in the event of any deviations resulting in additional cost over the tendered value sum being ordered, will be extended, if requested by the contractor, as follows:

- i. In the proportion which the additional cost of the altered, additional or substituted work, bears to the original tendered value, plus
- ii. 25% of the time calculated in (i) above or such further additional time as may be considered reasonable by the Engineer-in-Charge.

**B. Extra Items and Pricing:** In the case of extra item(s) which cannot be determined under Part-B of the schedule of quantities, the contractor may within fifteen days of receipt of order or occurrence of the item(s), claim rates, supported by proper analysis, for the work and the Engineer-in-charge shall within one month of the receipt of the claims supported by analysis, after giving consideration to the analysis of the rates submitted by the contractor, determine the rates on the basis of the market rates and the contractor shall be paid in accordance with the rates so determined.

In the case of substituted items, the rate for the agreement items (to be substituted) and substituted item shall also be determined in the manner as mentioned in the following para:

**C. Substituted Items and Pricing:**

- i. If the market rate for the substituted item so determined is more than the market rate of the agreement item (to be substituted) the rate payable to the contractor for the substituted item shall be the rate for the agreement item (to be substituted) so increased to the extent of the difference between the market rates of substituted item and the agreement item (to be substituted).
- ii. If the market rate for the substituted item so determined is less than the market rate of the agreement item (to be substituted) the rate payable to the contractor for the substituted item shall be the rate for the agreement item (to be substituted) so decreased to the extent of the difference between the market rates of substituted item and the agreement item (to be substituted).

**D. Deviated Quantities and Pricing:** In the case of contract items, substituted items, contract cum substituted items, which exceed the limits of 30% for building work, 100% for foundation work and 50% for maintenance work, the contractor may within **15 days** of receipt of order or occurrence of the excess, claim revision of the rates, supported by proper analysis, for the work



in excess of the above mentioned limits, provided that if the rates so claimed are in excess of the rates specified in the schedule of quantities, the Engineer-in-Charge shall within one month of receipt of the claims supported by analysis, after giving consideration to the analysis of the rates submitted by the contractor, determine the rates on the basis of the market rates and the contractor shall be paid in accordance with the rates so determined.

The provisions of the preceding paragraph shall also apply to the decrease in the rates of items for the work in excess of the aforesaid limits, and the Engineer-in-Charge shall after giving notice to the contractor within one month of occurrence of the excess and after taking into consideration any reply received from him within **15 days** of the receipt of the notice, revise the rates for the work in question within one month of the expiry of the said period of **15 days** having regard to the market rates.

Any operation incidental to or necessarily has to be in contemplation of tenderer while filing tender, or necessary for proper execution of the item included in the Bill of Quantities mentioned above, whether or not, specifically indicated in the description of the item and the relevant specifications, shall be deemed to be included in the rates quoted by the tenderer. Nothing extra shall be admissible for such operations.

**14. Foreclosure of contract due to abandonment or reduction in scope of work:** If at any time after acceptance of the tender, TIFR-Hyderabad shall decide to abandon or reduce the scope of the works for any reason whatsoever and hence not require the whole or any part of the works to be carried out, the Engineer-in-charge shall give notice in writing to that effect to the contractor and the contractor shall act accordingly in the matter. The contractor shall have no claim to any payment of compensation or otherwise whatsoever, on account of any profit or advantage which he might have derived from the execution of the works in full but which he did not derive in consequence of the foreclosure of the whole or part of the works.

**15. Suspension of work:**

i. The contractor shall, on receipt of the order in writing of the Engineer-in-Charge, (whose decision shall be final and binding on the contractor) suspend the progress of the works or any part thereof for such time and in such manner as the Engineer-in-Charge may consider necessary so as not to cause any damage or injury to the work already done or endanger the safety thereof for any of the following reasons:

ii. On account of any default on the part of the contractor or b. for proper execution of the works or part thereof for reasons other than the default of the contractor; or c. for safety of the works or part thereof.

iii. The contractor shall, during such suspension, properly protect and secure the works to the extent necessary and carry out the instructions given in that behalf by the Engineer-in-Charge.

iv. If the suspension is ordered for reasons (b) and (c) in sub-para (i) above:

v. The contractor shall be entitled to an extension of time equal to the period of every such suspension PLUS 25%, for completion of the item or group of items of work for which a separate period of completion is specified in the contract and of which the suspended work forms a part, and;

vi. If the total period of all such suspensions in respect of an item or group of items or work for which a separate period of completion is specified in the contract exceeds thirty days, the contractor shall, in addition, be entitled to such compensation as the Engineer-in-Charge may consider reasonable in respect of salaries and/or wages paid by the contractor to his employees

and labour at site, remaining idle during the period of suspension, adding thereto 2% to cover indirect expenses of the contractor provided the contractor submits his claim supported by details to the Engineer-in-Charge within fifteen days of the expiry of the period of 30 days.

vii. If the works or part thereof is suspended on the orders of the Engineer-in-Charge for more than three months at a time, except when suspension is ordered for reason (a) in Sub-Para (i) above, the contractor may after receipt of such order serve a written notice on the Engineer-in-Charge requiring permission within fifteen days from receipt by the Engineer-in-Charge of the said notice, to proceed with the work or part thereof in regard to which progress has been suspended and if such permission is not granted within that time, the contractor, if he intends to treat the suspension, where it affects only a part of the works as an omission of such part by TIFR or where it affects whole of the works, as an abandonment of the works by TIFR, shall within ten days of expiry of such period of 15 days give notice in writing of his intention to the Engineer-in-Charge. In the event of the contractor treating the suspension as an abandonment of the contract by TIFR, he shall have no claim to payment of any compensation on account of any profit or advantage which he might have derived from the execution of the work in full but which he could not derive in consequence of the abandonment. He shall, however, be entitled to such compensation, as the Engineer-in-Charge may consider reasonable, in respect of salaries and/or wages paid by him to his employees and labour at site, remaining idle in consequence adding to the total thereof 2% to cover indirect expenses of the contractor provided the contractor submits his claim supported by details to the Engineer-in-Charge within 30 days of the expiry of the period of 3 months.

**16. Action in case of work not done as per specifications:** All works under or in course of execution or executed in pursuance of the contract, shall at all times be open and accessible to the inspection and supervision of the Engineer-in-charge, his authorized subordinates in charge of the work and all the superior officers of the Department or any organization engaged by the Department for Quality Assurance and of the Chief Technical Examiner's Office, and the contractor shall, at all times, during the usual working hours and at all other times at which reasonable notice of the visit of such officers has been given to the contractor, either himself be present to receive orders and instructions or have a responsible agent duly accredited in writing, present for that purpose. Orders given to the Contractor's agent shall be considered to have the same force as if they had been given to the contractor himself.

If it shall appear to the Engineer-in-charge or his authorized subordinates in-charge of the work or his subordinate officers or the officers of the organization engaged by the Department for Quality Assurance or to the Chief Technical Examiner or his subordinate officers, that any work has been executed with unsound, imperfect, or unskillful workmanship, or with materials or articles provided by him for the execution of the work which are unsound or of a quality inferior to that contracted or otherwise not in accordance with the contract, the contractor shall, on demand in writing which shall be made within twelve months (six months in the case of work costing. 10 Lakh and below except road work) of the completion of the work from the Engineer-in-Charge specifying the work, materials or articles complained of notwithstanding that the same may have been passed, certified and paid for forthwith rectify, or remove and reconstruct the work so specified in whole or in part, as the case may require or as the case may be, remove the materials or articles so specified and provide other proper and suitable materials or articles at his own charge and cost. In the event of the failing to do so within a period specified by the Engineer-in-Charge in his demand aforesaid, then the contractor shall be liable to pay compensation at the same rate as under clause III(1) of the contract (for non-completion of the work in time) for this default In such case the Engineer-in-Charge may not accept the item of work at the rates

applicable under the contract but may accept such items at reduced rates. Decision of the Engineer-in-Charge to be conveyed in writing in respect of the same will be final and binding on the contractor.

- 17. Contractor liable for damages, defects during Maintenance (Defect Liability Period):** If the contractor or his working people or servants shall break, deface, injure or destroy any part of building in which they may be working, or any building, road, road kerb, fence, enclosure, water pipe, cables, drains, electric or telephone post or wires, trees, grass or grassland, or cultivated ground contiguous to the premises on which the work or any part of it is being executed, or if any damage shall happen to the work while in progress, from any cause whatever or if any defect, shrinkage or other faults appear in the work within **12 months (6 months** in the case of work costing **Rs. 10,00,000/- and below** except road work) after a certificate final or otherwise of its completion shall have been given by the Engineer-in-Charge as aforesaid arising out of defective or improper materials or workmanship, the contractor shall upon receipt of a notice in writing on that behalf make the same good at his own expense, or in default, the Engineer-in-Charge cause the same to be made good by other workmen and deduct the expense from any sums that may be due, or at any time thereafter may become due to the contractor, or from his security deposit, or the proceed of sale thereof or of a sufficient portion thereof. The security deposit of the contractor shall not be refunded before the expiry of **12 months (6 months** in the case of work costing **Rs.10,00,000/- and below** except road work) after the issue of the certificate final or otherwise, of completion of work, or till the final bill has been prepared and passed whichever is later. Provided that in the case of road work, if in the opinion of the Engineer-in-Charge, half of the security deposit is sufficient to meet all the liabilities of the contractor under this contract, half of the security deposit will be refundable after **6 months** and the remaining half after **12 months** of the issue of the said certificate of completion or till the final bill has been prepared and passed whichever is later. Performance Security shall be refunded to the contractor after completion of the work and recording the completion certificate.
- 18. Contractor to supply tools & plants etc.:** The contractor shall provide at his own cost all materials (except such special materials, if any, as may in accordance with the contract be supplied from the Engineer-in-Charge's stores), machinery, tools & plants. in addition to this, appliances, implements, other plants, ladders, cordage, tackle, scaffoldings and temporary works required for the proper execution of the work, whether original, altered or substituted and whether included in the specification or other documents forming part of the contract or referred to in these conditions or not, or which may be necessary for the purpose of satisfying or complying with the requirements of the Engineer-in-Charge as to any matter as to which under these conditions he is entitled to be satisfied, or which he is entitled to require together with carriage therefore to and from the work. The contractor shall also supply without charge the requisite number of persons with the means and materials, necessary for the purpose of setting out works, and counting, weighing and assisting in the measurement or examination at any time and from time to time of the work or materials. Failing his so doing, the same may be provided by the Engineer-in-Charge at the expense of the contractor and the expenses may be deducted, from any money due to the contractor, under the contract and/or from his security deposit or the proceeds of sale thereof, or of a sufficient portions thereof.
- 19. Recovery of compensation paid to workmen :** In every case in which by virtue of the provisions of section 12 sub-section (1) of the Workmen's Compensation Act. 1923, TIFR is obliged to pay compensation to a workman employed by the contractor, in execution of the works, TIFR will recover from the contractor the amount of the compensation so paid; and, without prejudice to the rights of TIFR under Section 12, sub-section (2) of the said Act, TIFR shall be at

liberty to recover such amount or any part thereof by deducting it from the security deposit or from any sum due by TIFR to the contractor whether under this contract or otherwise. TIFR shall not be bound to contest any claim made against it under section 12, sub-section (1) of the said Act, except on the written request of the contractor and upon his giving to TIFR full security for all costs for which TIFR might become liable in consequence of contesting such claim.

**20. Ensuring payment and amenities to workers if contractor fails:** In every case in which by virtue of the provisions of the Contract Labour (Regulation and Abolition) Act, 1970 and of the contract labour (Regulation and Abolition) Central Rules, 1971, TIFR is obliged to pay any amounts of wages to a workman employed by the contractor in execution of the works, or to incur any expenditure in providing welfare and health amenities required to be provided under the above said Act and the Rules, under Clause 19 H or under the DAE Contractor's Labour Regulations, or under the rules framed by Government from time to time for the protection of health and sanitary arrangements for workers employed by Department of Atomic Energy contractors, TIFR will recover from the contractor the amount of wages so paid or the amount of expenditure so incurred; and without prejudice to the rights of TIFR under Section 20, sub-section (2) and Section 21, sub-section (4) of the contract labour (Regulation and Abolition) Act, 1970, TIFR shall be at liberty to recover such amount or any part thereof by deducting it from the security deposit or from any sum due by TIFR to the contractor whether under this agreement or otherwise. TIFR shall not be bound to contest any claim made against it under Section 20, subsection (1) and section 21, sub-section (4) of the said Act, except on the written request of the contractor and upon his giving to TIFR full security for all costs for which TIFR might become liable in contesting such claim.

**21. Labour laws to be complied by the contractor:** The contractor shall obtain a valid license under the Contract Labour (R & A) Act, 1970 and the Contract Labour (Regulation and Abolition) Central Rules, 1971, before the commencement of the work, and continue to have a valid license until the completion of the work. The contractor shall also abide by the provision of the Child Labour Prohibition & Regulation) Act-1998. The contractor shall also comply with the provisions of the building and other Construction Workers (Regulation of Employment & Conditions of Service) Act, 1996 and the building and other Construction

Workers Welfare Cess Act, 1996. Any failure to fulfill these requirements shall attract the penal provisions of this contract arising out of the resultant non execution of the work.

**22. Minimum wages act to be compiled with:** The contractor shall comply with all the provisions of the Minimum Wages Act, 1948, Contract Labour (Regulation and Abolition) Act, 1970 and rules framed there under and other labour laws affecting contract labour that may be brought into force from time to time.

**23. Settlement of Disputes & Arbitration:** Any dispute arising from this contract will be referred to two arbitrators one to be appointed by you and one by us. The two arbitrators, in the event of their disagreement will appoint an Umpire. The decision of the Umpire shall be final and binding. The arbitration will proceed as per Indian Arbitration Act, 1940, as amended up to date.

**24. Confidential Information :** The drawings, specifications, proto-type, samples and such other information furnished to the contractor relating to the supply / work, sub-systems / equipment etc. are to be treated as confidential which shall be held by the contractor in confidence and shall not be divulged to any third party without the prior written consent of the Department. The contractor, therefore, binds himself, his successors, heirs, executors, administrators, employees and the permitted assignees or such other persons or agents directly or indirectly concerned with the work / supply to the confidential nature of the drawings, specifications, proto-

type samples etc. It is a further condition of the contract that the contractor shall not, without prior written permission from the Department, transmit, transfer, exchange, gift or communicate any such confidential information, and also the component, sub assembly, products, by-products etc. pursuant to the fabrication under taken by the contractor, to any third party.

**25. Safety with Scaffolding and Mobile Elevated Platform:** Every scaffold or mobile elevated platform and its supporting members, railings, Tee-boards, ropes should be designed to support given load, with a safety factor of at least four. No alterations should be made that might impair the strength of such structures, no improvised, make-shift or substandard scaffold should be permitted even for the most temporary use. All work in connection with such structures, including construction, operation, maintenance, alteration and removal should be carefully done under the direction and supervision of persons with specialized experience in such works. A safe and convenient means of access should be provided to the platform or scaffold. Means of access may be a portable ladder, fixed ladder, ramp or it may be a stairway. The use of cross braces or frame work as means of access to the working surface should not be permitted.

**26.** The TIFR-Hyderabad shall not be responsible for any accident/injury or loss of life of any of the persons engaged by the contractor that may take place while executing the contract. Any compensation or expenditure towards the treatment of such injury or loss of life shall be sole responsibility of the contractor. **At his cost, the contractor shall obtain appropriate/adequate insurance policy to his personnel towards meeting the liability of compensation arising out of death, injury, disablement, etc. at work.**

**27. Other Damages:**

i) The Contractor/Supplier/Manufacturer shall be responsible for all injury to persons, animals or things and for all damage to the works, structure of, and decorative work in the property which may arise from operation or neglect of himself or any of his Subcontractor or of his or Sub-Contractor's employees, whether such injury or damage may arise from carelessness, accident or any other cause whatever in any way connected with the carrying out of this contract. This clause shall be held to include any damage to buildings, whether immediately adjacent or otherwise, any damage to roads, streets, foot paths, as well as all damage caused to the works forming the subject of this contract by frost or other inclemency of weather. The Contractor/Supplier shall indemnify the Purchaser and hold him harmless in respect of all and any expenses on property as aforesaid and also in respect of any claim made in respect of injury or damage under any acts of Government or otherwise and also in respect of any award of compensation or damages consequent upon such claim. Contractor shall furnish necessary insurance documents (**Contractor All Risk Policy**) taken for the site before commencement of work.

ii) The Contractor/Supplier/Manufacturer shall reinstate all damage of every sort mentioned in this clause, so as to deliver up the whole of the contract works complete and perfect in every respect and so as to make good or otherwise satisfy all claims for damage to the property of the Owner/third parties.

iii) The Contractor/Supplier/Manufacturer shall indemnify the Purchaser against all claims which may be made against the Purchaser, by any member of the public or other party, in respect of anything which may arise in respect of the works or in consequence thereof and shall, at his own expense, effect and maintain, until the work has been 'Taken Over' under clause 5.



- iv)** The Contractor/Supplier/Manufacturer shall also indemnify the Purchaser against all claims which may be made upon the Purchaser whether under the Workmen's Compensation Act or any other statute in force during the currency of this contract or at common law in respect of any employee of the Contractor/Supplier or of any of his sub-contractor and shall at his own expense effect and maintain until the work has been 'Taken Over', with an approved office. Contractor shall furnish a copy of the labour licence before commencement of work. If the aforesaid are not applicable contractor should furnish declaration to this effect and shall indemnify TIFR-Hyderabad, Hyderabad for violation of any such compliances.
- v)** The Purchaser, with the concurrence of the Engineer In-Charge, shall be at liberty and is hereby empowered to deduct the amount of any damages compensation costs, charges and expenses arising or accruing from or in respect of any such claims or damages from any sums due to or become due to the Contractor/Supplier.

**SECTION – VI**

**SPECIAL CONDITIONS OF CONTRACT**

**I. GENERAL**

1. Special Conditions of Contract (SCC) shall be read in conjunction with the General Conditions of Contract (GCC) also referred to as General Terms & Conditions of Works Contract, Schedule of Quantities, specifications of work, drawings and any other document forming part of this Contract wherever the context so requires.
2. Notwithstanding the sub-division of the document into these separate sections and volumes, every part of each shall be deemed to be supplementary of every other part and shall be read with and into the Contract so far as it may be practicable to do so.
3. Where any portion of the GCC is repugnant to or at variance with any provisions of the Special Conditions of Contract, then unless a different intention appears, the provision(s) of the Special Conditions of Contract shall be deemed to override the provision(s) of GCC only to the extent that such repugnancy or variations in the Special Conditions of Contract are not possible of being reconciled with the provisions of GCC.
4. Wherever it is stated in this Bidding Document that such and such a supply is to be affected or such and such a work is to be carried out, it shall be understood that the same shall be affected and /or carried out by the Contractor at his own cost, unless a different intention is specifically and expressly stated herein or otherwise explicit from the context. Contract Price shall be deemed to have included such cost.
5. The materials, design & workmanship shall satisfy the applicable relevant Indian Standards, the job specifications contained herein & codes referred to. Where the job specifications stipulate requirements in addition to those contained in the standard codes and specifications, these additional requirements shall also be satisfied. In the absence of any Standard / Specifications / Codes of practice for detailed specifications covering any part of the work covered in this bidding document, the instructions / directions of Engineer-in-Charge will be binding upon the Contractor.
6. In case of contradiction between relevant Indian standards, GCC, Special Conditions of Contract, Specifications, Drawings and Schedule of Rates, the following shall prevail in order of precedence.
  - a) Detailed Purchase Order along with statement of agreed variations, if any, and its enclosures.
  - b) Letter of Intent(LOI)
  - c) Schedule of Quantities
  - d) Special Conditions of Contract
  - e) Instructions to Bidders
  - f) General Conditions of Contract
  - g) Technical Specifications
  - h) Relevant Indian Standards.
  - i) Drawings/ Data Sheets

---

## **II THE WORK**

### **1. Scope of Work & Scope of Supply**

The scope of work covered in this Contract will be as described in scope & objective of work provided in Section-I of important information to bidders, Schedule of Quantities, Technical Specifications, Drawings, etc.

### **2. Time Schedule**

The Completion period for this job shall be as given in this bid document. Time is the essence of this Contract. The period of completion given includes the time required for mobilization as well as testing, rectifications, if any, retesting, demobilization and completion in all respects to the satisfaction of the Engineer-in-Charge.

A joint programme of execution of work will be prepared by the Engineer-in-Charge and Contractor. This programme will take into account the time of completion period of the Contract.

Monthly execution programme will be drawn up by the Engineer-in-Charge jointly with the Contractor based on availability of materials, work fronts and the joint programme of execution as referred to above. The Contractor shall scrupulously adhere to the Targets / Programme by deploying adequate personnel, Construction Equipment, Tools and Tackles and also by Timely Supply of required materials coming within his scope of supply as per Contract. In all matters concerning the extent of target set out in the monthly programme and the degree of achievement, the decision of the Engineer-in-Charge will be final and binding upon the Contractor.

Contractor shall give every day category-wise labour and equipment deployment report along with the progress of work done on previous day in the pro-forma prescribed by the Engineer-in-Charge.

### **3. Temporary Works**

All temporary works, enabling works, including dewatering of surface and subsoil water, preparation and maintenance of temporary drains at the work site, preparation and maintenance of approaches to working areas, adequate lighting, wherever required, for execution of the work, shall be the responsibility of the Contractor and all costs towards the same shall be deemed to have been included in the quoted prices.

### **4. Quality Assurance**

Detailed quality assurance program to be followed for the execution of Contract under various divisions of works will be mutually discussed and agreed to.

The Contractor shall establish, document and maintain an effective quality assurance system as outlined in the specifications and various codes and standards.

The Owner/Consultant or their representative shall reserve the right to inspect/witness, review any or all stages of work at shop/site as deemed necessary for quality assurance and / or timely completion of the work.

In case Contractor fails to follow the instructions of Engineer-in-Charge with respect to above clauses, next payment due to him shall not be released unless and until he complies with the



instructions to the full satisfaction of Engineer-in-Charge.

#### **5. Labour License**

Before starting of work, Contractor shall obtain a license from concerned authorities under the Contract Labour (Abolition and Regulation) Act 1970, and furnish copy of the same to Owner.

#### **6. Labour Relations**

In case of labour unrest/labour dispute arising out of non-implementation of any law, the responsibility shall solely lie with the Contractor and they shall remove/resolve the same satisfactorily at his cost and risk.

The Contractor shall at all times take all reasonable precautions to prevent any unlawful, riotous or disorderly conduct by or amongst his staff and labour and to preserve peace and protection of persons and property in the neighborhood of the Works against such conduct.

#### **7. Site Cleaning**

The Contractor shall clean and keep clean the work site from time to time to the satisfaction of the Engineer-in-Charge for easy access to work site and to ensure safe passage, movement and working.

The Contractor shall dispose off the unserviceable materials, debris etc., to the earmarked area within the premises or any other location outside the premises as per the Contract and/or as decided by the Engineer-in-Charge. No extra payment shall be paid on this account.

#### **8. Review/Approval of Drawings, Design and other documents submitted by Contractor**

TIFR, HYDERABAD/Consultant will normally require and utilize a maximum time frame of seven (07) working days from the date of Receipt for Review/Approval of Drawings and other documents submitted by Contractor. Upon Review of the submitted documents, TIFR, HYDERABAD may give their comments and ask for modification/resubmission after necessary rectifications/modifications and the time frame of 7 working days will be applicable for same.

#### **9. Protection of Existing Facilities**

Contractor shall obtain all clearance (work permit) from the Owner, as may be required from time to time, prior to start of work. Work without permit shall not be carried out within the existing premises.

Contractor shall obtain plans and full details of all existing and planned facilities/services/utilities from the Owner and shall follow these plans closely at all times during the performance of work. Contractor shall be responsible for location and protection of all facilities/utilities and structures at his own cost.

Despite all precautions, should any damage to any structure / utility etc. occur, the Contractor shall contact the Owner / authority concerned and Contractor shall forthwith carry out repair at his expenses under the direction and to the satisfaction of Engineer-in- Charge and the Owner/concerned authority. Contractor shall take all precautions to ensure that no damage is caused to the existing facilities etc., during construction. Existing structures/ facilities/ utilities damaged / disturbed during construction shall be repaired and restored to their original condition by Contractor after completion of construction to the complete satisfaction of Owner.

## **10. Work Front**

The work involved under this Contract may include such works as have to be taken up and completed after other agencies have completed their jobs. The Contractor will be required and bound to take up as and when the fronts are available for the same and no claim of any sort whatsoever shall be admissible to the Contractor on this account. Only extension of time limit shall be admissible, if the availabilities of work fronts to the Contractor are delayed due to any reason not attributable to the Contractor and the same is clearly recorded.

## **11. Site Facilities**

The Contractor shall arrange for the following facilities at site, for workmen deployed/engaged by him / his sub- contractor, at his own cost:

- a) Arrangement for First Aid.
- b) Arrangement for clean & potable drinking water.
- c) Contractor's Site Office and Stores

Owner shall provide land only for contractor's site office and stores and fabrication yard, if any at site. However, same shall be dismantled prior to submission of Final Bill.

The Contractor shall remove all temporary buildings / facilities etc., before leaving the site after completion of works in all respect.

## **12. Construction Power and Water**

TIFR shall provide metered and chargeable power at a single point and the Contractor shall be exclusively responsible for the safety and to make his own arrangements for supply of power as per required.

Water required for the works shall be provided by TIFR depending upon the availability for free of cost. If not, the contractor has to make own necessary arrangement at own cost for drawing water including making temporary storage, pumping etc. TIFR will not pay any extra charges.

## **13. Cement & Steel:**

Cement required for execution of the job under the scope of this tender shall be supplied by the contractor at his own cost. Cement used shall be 53 grade Ordinary Portland cement (OPC) for all concrete works and 43 Grade Ordinary Portland cement (OPC) for other works. In case 43 grades OPC is not available, Portland Slag Cement or Portland Pozzolanic Cement may be permitted by TIFR, HYDERABAD after review of the same. Contractor to include the cost of cement required for execution of various items included in this tender in their quoted rates. Cement shall be of Grade as specified in the SOQ and shall conform to relevant BIS standards of latest edition.

The contractor will be required to maintain a stock register for receipt, issuance and daily consumption of cement at site. Cement shall be regulated on the basis of 1st receipt to go as 1st issue. Cement not consumed within 3 months after bringing to site shall not be used and shall be removed from site with prior written permission of EIC.

Contractor shall construct suitable temporary godown at site for storage of cement under his lock and key. The contractor will be fully responsible for safe custody of cement.

TIFR, HYDERABAD will not entertain any claims by the Contractor for theft, loss or damages to

cement. Contractor shall not remove from the site any cement bags at any time.

Entire quantity of reinforcement steel required for the project shall be supplied and provided at site by the contractor at his own cost. TIFR, HYDERABAD shall not supply any reinforcement steel. The contractor shall make necessary arrangement at his own cost for unloading, storage of steel in the open duly fenced under locking arrangement. The Contractor shall produce invoice for the reinforcement steel to EIC for every batch of procurement along with Manufacturer's Test Certificate.

No payment will be made or measurement recorded for binding wires which shall be of specified gauge and shall be provided by the contractor. All binding wires required for tying the reinforcement in position etc. will be supplied by the contractor. Cost of this binding wire and labour will be included in the item for binding and placing reinforcement in position.

It will be necessary that the contractor get the cement and steel tested at his own cost at TIFR, HYDERABAD approved laboratory as per the testing schedule or as per the EIC's advise.

The contractor will be required to maintain a register for recording details of steel receipt, steel utilized and balance at site.

In every case, it shall be the contractor's responsibility to ensure the standard of quality and the correctness of quantity of steel procured at site by him.

#### **14. Rules and Regulations**

Contractor shall observe in addition to Codes specified in respective specification, all national and local laws, ordinances, rules and regulations and requirements pertaining to the work and shall be responsible for compliance to the same.

#### **15. Procedures**

Various procedures and method statements to be adopted by Contractor during the construction as required & sought by TIFR, HYDERABAD and as per the respective specifications shall be submitted to Engineer-in-Charge in due time for approval.

#### **16. Security**

As the premises at TIFR, HYDERABAD is a protected area, entry into the area shall be restricted and may be governed by issue of photo gate passes. The Contractor shall arrange to obtain through the Engineer-in-Charge, well in advance, all necessary entry permits/gate passes for his staffs and laborers and entry and exit of his men and materials shall be subject to vigorous checking by the security staff. The Contractor shall not be eligible for any claim or extension of time whatsoever on this account.

It shall be the responsibility of the contractor to safeguard all his materials/owned from theft, damage etc. For this purpose the contractor shall be allowed to keep his own security inside TIFR, HYDERABAD premises.

#### **17. Drawings and Documents**

Drawings accompanying the Bidding Document are indicative of scope of work and issued for bidding purpose only. Purpose of these drawings is to enable the bidder to make an offer in line with the requirements of the owner.

The contractor as per 'scope of work' shall submit detailed designs including calculations, shop drawings, joinery details etc by a Govt. approved/ licensed Structural Engineer confirming structural stability which will be examined and approved by the Engineer-In-Charge with deviations if required before taking up the work.

#### **18. Contractor's Billing System**

TIFR, HYDERABAD will provide an approved format for Measurement sheets, Bill Summary and Bill Abstract. Contractor has to ensure that these data are updated for each subsequent RA and Final Bill.

TIFR, HYDERABAD will utilize these data for processing and verification of the Contractor's bill. Contractor's RA Bills shall be accompanied by progress photographs.

#### **19. Site Organization**

The Contractor shall without prejudice to his overall responsibility to execute and complete the works as per specifications and time schedule progressively deploy adequate qualified and experienced personnel together with skilled / unskilled manpower and augment the same as decided by Engineer-in-Charge depending on the exigencies of work to suit the construction schedule without any additional cost to Owner.

The Contractor shall provide all necessary superintendence during the execution of the Works and as long thereafter as the Engineer-in-Charge may consider necessary for the proper fulfilling of the Contractor's obligations under the Contract Such superintendence shall be given by sufficient persons having adequate knowledge of the operations to be carried out (including the methods and techniques required, the hazards likely to be encountered and methods of preventing accidents) for the satisfactory and safe execution of the Work. The workmen deployed by the Contractor should also possess the necessary license etc., if required under the existing laws, rules and regulations.

#### **20. Responsibility of Contractor**

It shall be the responsibility of the contractor to obtain the approval for any revision and/or modifications decided by the contractor from the Owner / Engineer-in-Charge before implementation. Also such revisions and / or modifications if accepted / approved by the Owner / Engineer-in-Charge shall be carried out at no extra cost to the owner. Any change required during functional requirements or for efficient running of system, keeping the basic parameters unchanged and which has not been indicated by the contractor in the data / drawings furnished along with the offer shall be carried out by the contractor at no extra cost to the owner.

All expenses towards mobilization at site and demobilization including bringing in equipment, work force, materials, dismantling the equipment, clearing the site etc. shall be deemed to be included in the prices quoted and no separate payments on account of such expenses shall be entertained.

It shall be entirely the contractor's responsibility to provide, operate and maintain all necessary construction equipment, steel scaffoldings and safety gadgets, cranes and other lifting tackles, tools and appliances to perform the work in a workman like and efficient manner and complete all the jobs as per time schedule.

Preparing approaches and working area for the movement of his men and machinery.

The procurement and supply in sequences and at the appropriate time of all materials, and consumables shall be entirely the contractor's responsibility and his rates for execution of work will be inclusive of supply of all these items.

**21. Coordination with other agencies**

Contractor shall be responsible for proper coordination with other agencies operating at the site of work so that work may be carried out concurrently, without any hindrance to others. The Engineer – in – Charge shall resolve disputes, if any, in this regard, and his decision shall be final and binding on the Contractor.

**22. Underground and overhead structures**

The Contractor will familiarize himself with and obtain information and details from the Owner in respect of all existing structures, and utilities existing at the job site before commencing work. The Contractor shall execute the work in such a manner that the said structures, utilities, etc. are not disturbed or damaged, and shall indemnify and keep indemnified the Owner from and against any destruction thereof or damages thereto.

**23. Documents required with final bill**

Statement of final bills – issue of No Claim/ No Due Certificate

The Contractor shall furnish a No-Claim/No-Due declaration indicating that there are no balance dues to his sub-vendor/sub- contractors/labour contractors along with the Final Bill.

**24. Working hours**

The work shall be carried out if required on round-the clock basis including holidays as it is a Greenfield site. Contractor's quoted rates are deemed to include expenditure towards working on round-the clock basis and holidays. However, Contractor's representative shall be available for overseeing the works at all times.

**III. TESTS, INSPECTION AND COMPLETION**

**1. Tests and Inspection**

The Contractor shall carry out the various tests as enumerated in the technical specifications of this Bidding Document and technical documents that will be furnished to him during the performance of the work at no extra cost to the Owner.

All the tests either on the field or at outside laboratories concerning the execution of the work and supply of materials by the Contractor shall be carried out by Contractor at his cost.

The work is subject to inspection at all times by the Engineer-in- Charge. The Contractor shall carry out all instructions given during inspection and shall ensure that the work is being carried out according to the technical specifications of this bidding document, the technical documents that will be furnished to him during performance of work and the relevant codes of practice.

All results of inspection and tests will be recorded in the inspection reports, pro-forma of which will be approved by the Engineer-in- Charge. These reports shall form part of the completion documents. Any work not conforming to execution drawings, specifications or codes shall be rejected and the Contractor shall carry out the rectifications at his own cost.

## **2. Final Inspection**

After completion of all tests as per specification the whole work will be subject to a final inspection to ensure that job has been completed as per requirement. If any defect is noticed, the Contractor will be notified by the Engineer-in-Charge and he shall make good the defects with utmost speed. If, however, the Contractor fails to attend to these defects within a reasonable time (time period shall be fixed by the Engineer-in-Charge) then Engineer-in-Charge may have defects rectified at Contractor's cost by engaging a third party.

## **3. Inspection of Items**

All inspection and tests on the items shall be made as required by specifications forming part of this contract. Various stages of inspection and testing shall be identified after receipt of Quality Assurance Program from the contractor / manufacturer. All incoming materials shall be accompanied by an IMIR (Incoming Material Inspection Report)

Inspection calls shall be given for association of Owner, as per mutually agreed program in prescribed pro-forma, giving details of item and attaching relevant test certificates and internal inspection report of the contractor.

The contractor shall ensure full and free access to the inspection engineer of Owner at the contractor's premises at any time during contract period to facilitate him to carry out inspection and testing assignments.

The contractor shall provide all instruments, tools, necessary testing and other inspection facilities to inspection engineer of Owner free of cost for carrying out inspection.

Where facilities for testing do not exist in the contractor's laboratories, samples and test pieces shall be drawn by the contractor in presence of Inspection Engineer of Owner and duly sealed by TIFR, HYDERABAD engineer and sent for tests in TIFR, HYDERABAD approved lab at the contractor's cost.

The contractor shall comply with the instructions of the Inspection Engineer fully and with promptitude. All inspections and tests shall be made as required by the specifications forming part of this contract. All costs towards testing etc. shall be borne by the contractor within their quoted rates.

## **4. Documentation**

Upon completion of work, the Contractor shall complete all drawings to "As built" status (including all vendor / Sub – vendor's drawings for bought out items) and provide the Owner, the following:

## **5. Supervisory Personnel**

Qualification and experience of key supervisory construction personnel to be deployed for this works shall be as given hereunder. CONTRACTOR shall submit bio data of key supervisory personnel meeting the requirement as given hereunder, after award, which will be reviewed and approved by Engineer-in-charge. However, deployment of qualified and experienced supervisory personnel of the CONTRACTOR shall be commensurate with the project work load and as approved by Engineer-in-Charge and / or OWNER.



---

Designation/ Category	Minimum Qualification	No. of Personnel	Discipline to which should belong
RESIDENT CONSTRUCTION MANAGER / RESIDENT ENGINEER / SITE-IN-CHARGE	Minimum Diploma with relevant field experience of minimum 5 years	1	Civil

<b>SECTION-VII</b>	<b>TECHNICAL CONDITIONS &amp; SPECIFICATIONS</b>
--------------------	--

**I. GENERAL NOTES:**

- i) The detailed specifications given hereinafter are for the items of works described in the schedule of quantities attached herein, and shall be guidance for proper execution of work to the required standards.
- ii) It may also be noted that the specifications are of generalized nature and these shall be read in conjunction with the description of item in schedule of quantities and drawings. The work also includes all minor details of construction which are obviously and fairly intended and which may not have been referred to in these documents but are essential for the entire completion in accordance with standard Engineering practice.
- iii) Unless specifically otherwise mentioned, all the applicable codes and standards published by the Indian Standard Institution and all other standards which may be published by them before the date of receipt of tenders, shall govern in all respects of design, workmanship, quality and properties of materials and methods of testing, method of measurements etc. Wherever any reference to any Indian Standard Specifications occurs in the documents relating to this contract, the same shall be inclusive of all amendments issued there to or revisions thereof, if any, up to the date of receipt of tenders.
- iv) In case there is no I.S.I. specification for the particular work, such work shall be carried out in accordance with the instructions in all respects, and requirements of the Engineer-in-Charge. Wherever any reference to any Indian Standard Specification occurs in the documents relating to this contract, the same shall be inclusive of all amendments issued there to or revisions thereof, if any, up to the date of receipt of tenders.
- v) The work shall be carried out in a manner complying in all respects with the requirements of relevant bye-laws of the Municipal Committee/Municipal Corporation/Development Authority/Improvement Trust under the jurisdiction of which the work is to be executed or as directed by the Engineer-in-Charge and, unless otherwise mentioned, nothing extra shall be paid on this account.
- vi) Samples of various materials, fittings etc. proposed to be incorporated in the work shall be submitted by the contractor for approval of the Engineer-in-charge before order for bulk supply is placed.
- vii) The contractor shall take instructions from the Engineer-in-Charge regarding collection and stacking of materials in any place. No excavated earth or building materials shall be stacked on areas where other buildings, roads, services, compound walls etc. are to be constructed.
- viii) The contractor shall maintain in perfect condition all works executed till the completion of the entire work awarded to him. Where phased delivery is contemplated, this provision shall apply to each phase.



- ix) The contractor shall give a performance test of the entire installation(s) as per standard specifications before the work is finally accepted and nothing extra whatsoever shall be payable to the contractor for the test.
- x) The contractor shall clear the site thoroughly of all scaffolding materials and rubbish etc. left out of his work and dress the site around the building to the satisfaction of the Engineer-in-Charge before the work is considered as complete.
- xi) **Post construction inspection and testing:** After completion of the work and during maintenance period liability of the contractor, the work shall also be subjected to 'Post construction inspection and testing'. In case the materials or articles incorporated in the work are found to be inferior, though the sample collected for the same might have been passed at the time of execution, it shall be the responsibility of the contractor to replace the same at his own cost, failing which the Department may rectify the same at the risk and cost of the contractor or Department may accept the work as sub-standard, and cost be adjusted from the outstanding security deposit, as per the terms and conditions of the contract for the work.
- xii) **The Head Technical Services, TIFRH**, shall be the sole deciding authority as to the meaning, interpretations and implications for various provisions of the specifications and his decision in writing shall be final and binding on all concerned.
- xiii) In case any difference or discrepancy between the specifications and the description in the schedule of quantities, the schedule of quantities shall take precedence. In case of any difference or discrepancy between specifications and drawing, the specifications shall take precedence.

## **II - LIST OF INDIAN STANDARDS:**

**Following are the various pertinent Indian Standards, relevant to buildings work:**

(All Latest Versions of I.S. codes shall be referred)

<b>I. S. CODE NO.</b>	<b>SUBJECT</b>
<b>1. CARRIAGE OF MATERIALS</b>	
4082-1996	Recommendations on stacking & storage of constn. materials and components at site.
<b>4. CONCRETE WORK</b>	
383-1970	Coarse and fine aggregate from natural sources for concrete (Reaffirm - 1990)
456-2000	Code of practice for plain and reinforced concrete
516-1959	Method of test for strength of concrete (Reaffirmed in 2004)
1199-1959	Method of sampling and analysis of concrete
1200 (Pt.II)-1987	Methods of measurements of cement concrete work. (Reaffirm - 1992)
1322-1993	Bitumen felts for water proofing and damp proofing. (Reaffirm - 1998)
1661-1987(Pt.III)	Code of practice for application of cement lime plaster finishes.(Reaffirm- 1999
2386-1977(Pt.1 to 8)	Methods of test for aggregate for concrete
2386 (Pt.I)-1963	Test for particle size and shape
2386 (Pt.II)-1963	Test for estimation of deleterious materials and organic impurities
2386 (Pt.III)-1963	Test for specific gravity, density, voids, absorption and bulking
2386 (Pt.IV)-1963	Mechanical properties
2645-1975	Specification for integral water proofing compounds
2686-1977	Specification for cinder aggregate for use in lime concrete. (Reaffirm - 1992)
3812-1981	Fly Ash using as pozzolana and admixtures for concrete. (Reaffirmed - 1999)
7861-1975 (Pt.I)	Hot weather concreting. .(Reaffirmed -1990)
7861-1981 (Pt.II)	Cold weather concreting. .(Reaffirmed -1992)
9103-1999	Admixture for concrete.
<b>5. R.C.C. WORK</b>	
432-1982	Mild steel & medium tensile steel bars and hard drawn steel wire for concrete reinforcement.
432 (Pt.I)-1982	Mild steel and medium tensile steel bars
456-2000	Code of practice for plain and reinforced concrete
457-1957	COP for general const. of plain & reinforced concrete for dams & other massive structure.
516-1959	Methods of test for strength of concrete

1161-1963	Specifications for steel tubes for structural purposes
1199-1959	Methods of sampling and analysis of concrete. (Reaffirmed - 1999)
1200 (Pt.II)-1974	Method of measurement of cement concrete work
1200(Pt.V)-1982	Method of measurement of form work. (Reaffirmed - 1989)
1343-1980	Code of practice for pre-stressed concrete.
1566-1982	Hard drawn steel wire fabric for concrete reinforcements (II Rev.) (Reff.1998)
1780-1961	Specifications for cold twisted steel bars for concrete reinforcement *
1785-1983 (Part-I & II)	Specifications for plain hard drawn steel wire for pre-stressed concrete
1786-1985	H.Y.S.D./ Cold twisted steel bars for concrete reinforcement Reaffirmed - 1990)
2090-1983	Specifications for high tensile steel bars used in prestressed concrete.
2204-1962	Code of practice for construction of reinforced concrete shell roof. (Reaffirmed - 1990)
2210-1988	Criteria for the design of shell structure and folded plates (Reaffirmed - 1998)
2502-1963	COP for bending and fixing of bars for concrete reinforcement. (Reaffirmed - 1999)
2750-1964	Specifications for steel scaffoldings
2751-1979(Reaf-1992)	COP for welding of mild steel bars used for reinforced concrete construction.
2911-1984	Code of practice for design & Constn. of pile foundations
2911(Pt.I)-1979.(Reaf-97).	Design & construction of Pile Foundations - Bored precast concrete piles.
2911 (Pt.III)-1980	Under reamed pile foundations
2911 (Pt.IV)-1985	Load test on Piles
3201-1988	Criteria for design and construction of precast concrete trusses. (Reaffirmed - 1995)
3370. (Part I to IV)-1965	Code of practice for concrete structures for storage of liquids. (Reaffirmed(1999)
3385-1965	Code of practice for measurement of Civil Engineering works - Pile Foundation)
3414-1968	Code of practice for design and installation of joints in buildings. (Reaffirmed - 1990)
3558-1983(Reaf-91)	Code of practice for use of immersion vibrators for consolidating concrete
3696 (Pt.I & II)	I-1987: Safety code of scaffoldings; II-1991: Safety code of ladders
3935-1966	Code of practice for composite construction. (Reaffirmed – 1998)
4014-1967 (Pt. & II)	COP for steel tubular scaffolding (I: Defination/Material; II: Safety Resolutions) (Raffir 1999)
4926-2003	Code of practice for Ready Mix Concrete
4990-1993	Specifications for plywood for concrete shuttering work. (Reaffirmed - 1998)

10262-1982	Code of practice for design mix. (Reaffirmed - 1999)
<b>6. EQUIPMENTS</b>	
460-1985(Pt-I,II& III)	Specification for test sieves. (Reaffirmed - 1998)
1791-1985	Specification for batch type concrete mixer. (Reaffirmed – 1990)
2430-1986	Methods for sampling of Aggregates for concrete.
2505-1992	General requirement for concrete vibrators, immersion type
2506-1985	General requirements for screed board concrete vibrators
2514-1963	Specification for concrete vibrating tables. (Reaffirmed - 1991)
3366-1965	Specification for pan vibrators. (Reaffirmed – 1991)
4656-1968	Specification for form vibrators for concrete. (Reaffirmed-1991)
2722-1964(Reaf-95)	Specification for portable swing weighbatchers for concrete (single and double bucket type).
2750-1964	Specification for steel scaffolding. (Reaffirmed – 1991)
<b>7. BRICK WORK:</b>	
1077-1992	Common burnt clay building bricks
1200 (Pt.III)-19920	Method of measurements of brick work. (Reaffirmed - 1992)
2116-1980	Sand for masonry mortars. (Reaffirmed - 1998)
2212-1991	Code of practice for brick work
2250-1981	Code of practice for preparation & use of masonry mortar. (Reaffirmed - 1990)
3102-1971	Classification of burnt clay solid bricks
3495 (Pt.I to IV)-1992	Method for test for burnt clay building brick
5454-1978	Method for sampling of clay building bricks. (Reaffirmed - 1995)
<b>9. MARBLE WORK:</b>	
1122-1974	Methods for determination of specific gravity and porosity of natural building stones
1124-1974	Methods of test for water absorption of natural building stones
1130-1969	Marble (blocks, slabs and tiles)
<b>11. STEEL WORK</b>	
63-1978	Whiting for paints. (Reaffirmed - 1994)
198-1978	Varnish, gold size. (Reaffirmed - 1991)
12406 - 1988	Medium density fibre board for general purpose - (1992)
277-2003	Specification for galvanised steel sheets (plain and corrugated)
278-1978	Galvanised steel barbed wire for fencing. (Reaffirmed - 1991)
800-1984	Code of practice for use of structural steel in general building construction

806-1968	Code of practice for use of steel tube in general building construction
813-1986	Scheme of symbols for welding. (Reaffirmed – 2003).
814-1991	Covered electrodes for metal arc welding of structural steel (Reaffirmed 2003)
814 (Pt-I)-1974	For welding products other than sheets. *
814 (Pt-II)-1974	For welding sheets. *
817-1966	Code of practice for training and testing of metal arc welders. (Reaffirmed – 2003)
818-1968 (Reaf-03)	COP for safety & healthy requirements in electric & gas welding & cutting operation.
1038-1983	Steel doors, windows and ventilators
1081-1960(Reaf-91)	COP for fixing & glazing of metal (steel & aluminium) doors, windows & ventilators
1148-1982(Reaf-92)	Hot rolled steel rivet bars (upto 40 mm diameters)for structural purposes (Reaffirmed 2001)
1161-1998	Steel tubes for structural purposes
1182-1983(Reaf-00)	Recommended practice for radiographic examination of fusion welded butt joints in steel plates.
1200 (Pt-VIII)-1993	Method of measurements of steel work and iron works
1363-1992 (Pt. 1- 3)	Hexagon bolts, nuts & lock nuts (dia. 6 to 39 mm) & black hexagon screws (dia. 6 to 24 mm). (Reaf-98)
1599-1985(Reaf-91)	Method for bend test for steel products other than sheet, strip, wire & tube (reaffirmed 1996).
1608-1995	Method for tensile testing of steel products (Reaffirmed 2001)
1821-1987	Dimensions for clearance holes for metric bolts. (Reaffirmed - 2003)
1852-1985	Rolling and cutting tolerance for hot rolled steel products. (Reaffirmed - 1991)
1977-1969	Structural steel (ordinary quality) (Reaffirmed 2001)
2062-1999	Structural steel (fusion welding quality). Supersedes IS 226-1975
4351-2003	Steel door frames. (Reaffirmed – 1991)
4736-1986	Hot-dip zinc coatings on steel tubes. (Reaffirmed – 2001)
6248-1979	Metal rolling shutters and rolling grills
7452-1990	Hot rolled steel sections for doors, windows & ventilators.
<b>12. FLOORING:</b>	
210-1993	Grey iron casting (Reaffirmed 1999)
653-1992	Sheet linoleum
777-1988	Glazed earthen-ware tiles
809-1992	Rubber flooring materials for general purpose
1122-1974	Methods for determination of specific gravity (*and porosity of natural building stones)
1124-1974	Method of test for water absorption of natural building stones

1130-1969	Marble (blocks, slabs and tiles). (Reaffirmed – 1993)
1197-1970	Code of practice for laying of rubber floors. (Reaffirmed – 1990)
1198-1982	Code of practice for laying and maintenance of linoleum floors
1200 (Pt.XI)-1977	Method of measurements of pavings and floor finishes.
1237-1980	Cement concrete flooring tiles. (Reaffirmed – 1990)
1443-1972	Code of practice for laying and finishing of cement concrete flooring tiles
1661-1972	Code of practice for application of cement and cement lime plaster finishes
2114-1984	Code of practice for laying in situ terrazzo floor finish
2571-1970	Code of practice for laying in situ cement concrete flooring
3400-1987 (Part 1 to 22)	Method of Test of vulcanized rubbers. (Reaffirmed – 2003)
3400 (Pt.II)-2003	Hardness
3400 (Pt.X)-1977	Compression set at constant strain. (Reaffirmed – 2003)
3462-1986	Flexible P.V.C. Flooring. (Reaffirmed – 1991)
4631-1986	Code of practice for laying of resin floor toppings (Reaffirmed – 2001)
5318-1969	Code of practice for laying of flexible P.V.C. sheet & tiles flooring
5389-1969	Code of practice for laying of hardwood parquet and wood block floors. (Reaffirmed – 1998)
9197-1979	Specifications for epoxy resin, hardeners and epoxy resin compositions for floor topping (Reaffirmed – 2001)
13630 (Pt.1 to 13)	Methods of tests for ceramic tiles (Part 1 to 13 : 1992-1993)
<b>13. ROOFING:</b>	
73-1992	Paving Bitumen (Reaffirmed 1998)
277-2003	Galvanised steel sheets (plain and corrugated)
458-2003	Concrete pipes (with and without reinforcement)
459-1992	Unreinforced corrugated and semicorrugated asbestos cement sheets
651-1992	Salt glazed stone ware pipes and fittings
702-1988	Industrial Bitumen
1199-1959	Method of Sampling & Analysis of concrete. (Reaffirmed - 1991)
1200 (Pt.IX)-1973	Method of measurements of roof covering (including cladding)
1200 (Pt.X)-1973	Method of measurements of ceiling and lining
13607 - 1992	Ready Mixed Paint, Finishing, General Purposes, Synthetic (Reaffirmed 2002)
1322-1993	Bitumen felts for water proofing and damp-proofing. (Reaffirmed -1988)
1346-1991	Code of practice for waterproofing of roof with bitumen felts
1609-1991	Code of practice for laying damp proof treatment using bitumen felts
1626-1994(Part I-III)	Asbestos cement building pipes, gutters and fittings (Spigot and socket types)

1834-1984	Specification for hot applied sealing compounds for joints in concrete. (Reaffirmed - 1990)
1838-(Pt.I & II)-1983	Preformed filler for expansion joints in concrete- non-extruding and resilient type Bitumen impregnated fiber). (Reaffirmed - 1990)
2115-1980	Code of practice for flat roof finish:mud phuska. (Reaffirmed - 1998)
2633-1986	Method of testing uniformity of coating on zinc coated articles. (Reaffirmed – 2001)
3007-(Pt.I)-1999	Code of practice for laying of corrugated asbestos cement sheets. (Reaffirmed – 1991)
3007-(Pt.II)-1965	Code of practice for laying of semi corrugated asbestos cement sheet. (Reaffirmed - 1991)
3348-1965	Fiber insulation boards. (Reaffirmed - 1990)
3607-1979	Magnesite for chemical Industry. (Reaffirmed – 2003)
7193-1994	Specifications for glass fiber base coal tar Pitch & Bitumen felts.
8183-1993	Bonded mineral wool. (Reaffirmed 2004)
<b>14. FINISHING</b>	
75-1973	Linseed oil, raw and refined. (Reaffirmed – 2003)
77-1976	Linseed oil, boiled, for paints. (Reaffirmed - 1999)
102-1962	Ready mixed paint, brushing, red, lead, non setting, priming.( Reaffirmed - 1996)
104-1979	Specification for ready mixed paint, brushing, zinc chrome, priming. (Reaffirmed - 1999)
133-1993	Enamel, interior (a) under coating (b) finishing colour as required
137-1965	Ready mixed paint, brushing, matt or egg-shell flat, finishing, interior, to Indian Standard Colour, as required. (Reaffirmed – 1999)
158-1981	Ready mixed paint, brushing, bituminous, black lead free acid alkali, water and heat resisting for general purposes. (Reaffirmed – 1999)
168-1993	Ready mixed paint, air drying for general purpose.(Reaffirmed 2002)
217-1988	Cut back bitumen (reaffirmed 1999)
218-1983	Creosote and anthracene oil for use as wood preservatives (Reaffirmed 1998)
290-1961	Coal tar black paint. (Reaffirmed – 1996)
337-1975	Varnish, finishing interior. (Reaffirmed – 2001)
341-1973	Black Japan, types A, B, and C (Reaffirmed 2002)
347-1975	Varnish, shellac for general purpose. (Reaffirmed – 2001)
348-1968	French polish. (Reaffirmed – 2001)
419-1967	Putty for use of window frames. (Reaffirmed – 2001)
427-1965	Distemper, dry, colour as required. (Reaffirmed – 1999)
428-2000	Washable distemper
524-1983	Varnish, finishing, exterior, synthetic. (Reaffirmed – 2000)
525-1968	Varnish, finishing, exterior and general purposes. (Reaffirmed –2001)

533-1998	Gum spirit of turpentine (oil of turpentine) (Reaffirmed 2003)
712-1984	Specification for building limes. (Reaffirmed - 1995)
1200 (Pt. XII)-1976	Method of measurements of plastering and pointing
1200 (Pt.XIII)-1994	Method of measurements of white washing, colour washing, distempering and other finishes
1200 (Pt.XV)-1987	Methods of measurements of painting, polishing & varnishing.
2095-1996 (Pt.I - III)	Gypsum plaster boards
2096-1992	Asbestos cement flat sheets.
2339-1963	Aluminium paint for general purposes, in dual container. (Reaffirmed – 1999)
2547-1976 (Pt I & II)	Gypsum building plaster (Reaff. 1992)
2932-2003	Enamel synthetic, exterior (a) Under coating (b) Finishing.
2933-1975	Enamel, Exterior (a) Under coating (b) Finishing
5410-1992	Cement paint (Reaffirmed 1999)
5411 (Pt.I)-1974	Plastic emulsion paint for interior use. (Reaffirmed – 1993)
6278-1971	Code of practice for white washing & colour washing. (Reaffirmed -1991)
<b>15. DEMOLITION AND DISMANTLING:</b>	
1200(Pt.XVIII)-1974	Method of measurements of demolition and dismantling
<b>16. SAFETY CODES</b>	
818-1968 (Reaf-03)	Safety and healthy requirements in Electric and gas welding and cutting operations.
3696 (Pt.I)-1987	Safety code for scaffolds
3696 (Pt.II)-1991	Safety code for ladders
3764-1992	Safety code for Excavation works
4081-1986	Safety code for blasting and related drilling operation
4130-1991	Safety code for Demolition of Building
5916-1970	Safety code for construction involving use of hot bituminous materials
6922-1973	Structural subject to under ground blasts code of practice for safety and design of
7293-1974	Working with construction machinery- safety code for



**III. MANDATORY TESTS:**

**NOTES:**

1. The mandatory tests shall be carried out when the quantity of materials to incorporate in the work exceeds the minimum quantity specified.
2. Optional tests specified or any other tests, shall be carried out in case of specialized works or important structures as per direction of the Engineer-in-Charge.
3. Testing charges, including incidental charges and cost of sample for testing shall be born by the contractor for all mandatory tests.
4. Testing charges for optional tests shall be reimbursed by the Department. However, the incidental charges and cost of sample for testing shall be born by the contractor.
5. In case of non-IS materials, it shall be the responsibility of the contractor to establish the conformity of material with relevant IS specification by carrying out necessary tests. Testing charges including incidental charge and cost of sample for testing shall be borne by the contractor for such tests.

**Annexure ‘A’-THE MANDATORY TESTS SHALL BE AS FOLLOWS:**

Material	Test	Field / laboratory test	Test procedure	Minimum quantity of material / Work for carrying out the test	Frequency of testing
Reinforced cement concrete work					
Water for construction purposes	Ph value Limits of Acidity Limits of Alkalinity Percentage of solids Chlorides Suspended matter Sulphates Inorganic solids Organic solids	Lab	IS 3025	Water from each source	Before commencement of work & thereafter: Mandatory - Once in one year from each source; Optional: once in 3 months from each source; Municipal supply - optional.
Reinforced cement concrete	a) slump test	Field	IS: 1199	a) 20 cu.m. for slabs, beams and connected columns . b) 5 Cu.m in case of cloumns	a) 20 cu.m. Part there of or more frequently as required by the Engr.-in-Charge. b) Every 5 Cu.m.

	b) cube test	Lab	IS: 516	a) 20 cu.m. In slab, beams, & connected columns. b) 5 cum in columns	Refer page no. 84 clause no. 6.7.1 for the frequency of test
Ready mixed cement concrete (IS-4926)	Cube test	Lab	IS-516 and as per para 6.3.2 of IS-4926-2003	50 cum	Refer page no. 84 clause no. 6.7.1 for the frequency of test
Note: for all other small items and where RCC done in a day is less than 5 cum, test may be carried out as required by Engineer-in-Charge.					

Material	Test	Field / laboratory test	Test procedure	Minimum quantity of material / Work for carrying out the test	Frequency of testing
Sand	Bulking of Sand	Field		20 CU.M.	Every 20 cu.m or part there of or more frequently as decided by Engineer-in-Charge
	Silt content	Field	IS:383	20 CU.M.	Every 20 cu.m or part there of or more frequently as decided by Engineer-in-Charge
	Particle size and distribution	Field or Laboratory as decided by the Engineer-in-Charge	IS:383	40 CU.M.	Every 40 cum. of fine aggregate / sand required in RCC. Work only
	Organic Impurities	Field	..DO..	20 CU.M.	Every 20 cu.m. or part thereof or more frequently as decided by the Engineer-in-Charge
	Chloride & sulphate content		Optional		Once in three months.

	tests				
Cement	Test requirement	Fineness (m2/kg)	IS 4031 (Part-II)	Each fresh lot	Every 50 MT or part thereof
		Normal consistency	IS 4031 (Part-IV)		
		Setting time (minutes) Initial Final	IS 4031 (Part-V)		
		Soundness a) Le-Chat expansion (mm) b) Auto clave (%)	IS 4031 (Part-III)		
		Compressive strength(Mpa) a) 72+/-1 hr b)168+/-2hr	IS 4031 (Part-VI)		
Stone Aggregate	a) Percentage of soft or deleterious materials	General visual inspection/ Lab test where required by the Engineer-in-Charge	IS 2386 Part II	One test for each source	One test for each source
	b) Particle size distribution	Field / Lab	-	10 cu.m	Every 40 cum. Or part thereof and
Once in three months for each source for coarse and fine aggregates required in RCC works, for a minimum quantity - 10 cum for coarse aggregate and 40 cum for fine aggregate.					
	a) Estimation of Organic impurities	Field / Lab	IS 2386 Part II	10 Cum	-do-
	b) Specific Gravity	Field / Lab	IS 2386	10 Cum	-do-
	Bulk Density	Field / Lab	IS 2386	10 Cum	-do-
	d) aggregate crushing strength	Field / Lab	IS 2386	10 Cum	-do-
	Aggregate impact value	Field / Lab	IS 2386	10 Cum	-do-

Material	Test	Field / laboratory test		Test procedure	Minimum quantity of material / Work for carrying out the test	Frequency of testing
Steel for RCC	Physical tests Tensile strength Retest Re-bound test Nominal mass Bend test Elongation test Proof stress	Lab / field	IS 1608 IS 1786 IS 1786 IS 1786 IS 1599 IS 1786 IS 1786	Each lot from each source from each diameter of bar	Below 100 Tonnes Dia < 10 mm one sample for each 25 tonnes or part thereof If dia is >10 mm but less than 16 mm: One sample each 35 tonnes or part thereof. If dia >16 mm one sample for each 45 tonnes	Above 100 Tonnes Dia < 10 mm one sample for each 40 tonnes or part thereof If dia is >10 mm but less than 16 mm One sample for each 45 tonnes or part thereof. If dia >16 mm one sample for each 50 tonnes.
	Chemical Tests: 1. Carbon Constituent 2. Sulphur 3. Phosphorus 4. Phosphorus & Sulphur	Lab	IS 1786			For every fresh lot of one truck or less as directed by the Engineer-in-Charge.
Soil core test	OMC Proctor density	Lab / field	As per IS 12175		Two for every 50 sqm	As per para 4.10 & 4.11 of this book

**OTHER MANDATORY TESTS:** Soil core tests; Testing aggregate - particle size distribution.

**OPTIONAL TESTS:** Testing aggregate-surface moisture, impact value spectrographic; alkali reaction; Dimensional tests of bricks; Testing structural steel; Chequered plate, Unit weight, Thickness, Chemical and physical properties.

**TESTING, TOLERANCE, ACCEPTANCE AND MODE OF PAYMENT:**

- a) The material should pass all tests and tolerance in dimensional, chemical, physical properties should be within the limit as stipulated in relevant IS for acceptance. Such materials shall be accepted as standard.
- b) Payment shall be restricted to standard unit mass, or as specified in the schedule of work, without making any cost adjustment towards mass or any other properties, provided the material pass all the tests and tolerances are within the specified limits.



- c) In case of non-standard materials, materials not covered under any IS Specifications, such as steel sections, the payment shall be made based on the actual unit weight basis as determined by testing at random sampling.

---

#### **IV. EARTH WORK:**

##### **4.1 SCOPE OF WORK:**

The scope of work covered under this specifications pertains to excavation of foundations, trenches, pits and over areas, in all sorts of soils, soft and hard rock, correct to dimensions given in the drawing including shoring, protections of existing underground utilities if any, such as water lines, electric cables etc., dewatering and shoring if necessary, stacking the useful materials as directed within the lead specified, refilling around the foundation and into the plinth with selected useful excavated earth and disposing off the surplus earth/materials within specified lead and finishing the surface to proper levels, slopes and camber etc. all complete.

##### **4.2 SITE CLEARANCE:**

Before the earth work is started the area coming under cutting and filling shall be cleared of all obstructions, loose stones, shrubs, rank vegetation, grass, brush-wood, trees and saplings of girth up to 30 cm. measured at a height of one meter above ground and rubbish removed up to a distance of 150 meters outside the periphery of the area under clearance. The roots of trees shall be removed to a minimum depth of 60 cm. below ground level, or a minimum of 30cm. below formation level whichever is lower, and the hollows filled up with earth, levelled and rammed. This work is deemed to be included in the earth work items and no separate payment will be admissible for the work.

The trees of girth above 30 cm. measured at a height of one meter above ground, shall only be cut after permission of the Engineer-in-charge is obtained in writing. The roots shall also be removed as described in the preceding sub-para. Payment for cutting and removing roots of such trees shall be made separately. Any material obtained from the site will be the property of the Department and the useful materials as decided by the Engineer-in-charge will be conveyed and properly stacked as directed within the lead specified.

##### **4.3 SETTING OUT AND MAKING PROFILES:**

Masonry or concrete pillars will be erected at suitable points in the area to serve as bench marks for the execution of the work. These bench marks shall be connected with G. T. S. or any other permanent bench mark approved by the Engineer-in-charge. Necessary profiles with pegs, bamboos and strings shall be made to show the correct formation levels before the work is started. The contractor shall supply labour and materials for setting out and making profiles for the work at his own cost and the same shall be maintained during the excavation work. The Department will show grid Co-ordinate or other reference points. It shall be the responsibility of the contractor to set out centre lines correctly with reference to the drawings and install substantial reference marks. Checking of such alignment by the Department will not absolve the contractor from his responsibility to execute the work strictly in accordance with the drawings.

##### **4.4 EXCAVATION:**

The contractor shall notify the Engineer-in-charge before starting excavation and before the ground is disturbed, to enable him to take existing levels for the purpose of measurements. The ground levels shall be taken at 5 to 15 meters intervals in uniformly sloping ground and at closer distance where local mounts, pits or undulations are met with, as directed by the Engineer-in-charge.

The ground levels shall be recorded in field books and plotted on plans, which shall be signed by the Contractor and the Engineer-in-charge, before the earth work is actually started. The labour required for taking levels, shall be supplied by the Contractor at his own cost. The Contractor shall perform excavation in all types of soils, murrum, soft and hard rock, boulders etc. in foundation, over areas and in trenches to widths, lines, levels, grades and curves as shown in the drawing or lesser widths, lines and levels as directed by the Engineer-in-charge and as per items in the schedule of quantities.

**4.4.1** The item in the schedule of quantities shall specify the excavation in trenches or over areas. For this purpose, the excavation for any depth in trenches for foundation not exceeding 1.5 m. in width or 10 sqm. on plan shall be described as **Excavation in foundation trenches**.

**4.4.2** Excavation exceeding 1.5m in width as well as 10 sqm. on plan (excluding trenches for pipes, cables etc.) and exceeding 30 cm in depth shall be described as **Excavation over areas**.

**4.4.3** Excavation exceeding 1.5m in width as well as 10 sqm. on plan but not exceeding 30 cm. in depth shall be described as **Surface Excavation**.

**4.5 Classification of Earth Work:** The earth work shall be classified under the following main categories and measured separately for each category.

- a) All types of soils, murrum, boulders.
- b) Soft rock.
- c) Hard rock.

**4.5.1 a) All types of Soils, Murrum, Boulders:** This includes earth, murrum, top deposits of agricultural soil, reclaimed soil, clay, sand or any combination thereof and soft and hard murrum, shingle etc. which is loose enough to be removed with spades, shovel and pick axes. Boulders not more than 0.03 cum. in volume found during the course of excavation shall also fall under this classification.

**b) Excavation in Soft Rock:** This shall include all materials which are rock or hard conglomerate, all decomposed weathered rock, highly fissured rock, old masonry, boulders bigger than 0.03 cum. in volume but not bigger than 0.5 cum. and other varieties of soft rock which can be removed only with pick axes, crow bars, wedges and hammers with some difficulty. The mere fact that the contractor resorts to blasting and/or wedging and chiseling for reasons of his own, shall not mean the rock is classifiable as hard rock.

**c) Excavation in Hard Rock:** This includes all rock other than soft rock mentioned in para 4.5.1 (b) viz. soft rock, occurring in masses, boulders having approximate volume more than 0.5 cum. plain or reinforced cement concrete, which can best be removed by blasting or chiseling and wedging where blasting cannot be permitted owing to any restriction at site.

**i) Excavation in Hard Rock by Blasting:** Where blasting is permitted the excavation in rock shall be done by means of blasting. No heavy blasting will be permitted and only controlled/muffled blasting will be permitted at the discretion of the Engineer-in-Charge. The Contractor shall be governed by the relevant statutory laws, rules and regulations on explosives, pertaining to the acquisition, transport, storage, handling and use of explosive which shall be rigidly followed and shall obtain himself all necessary materials and equipment for blasting. Blasting shall be executed through a

licensed blaster with prior permission from police authorities. Prior to blasting sufficient notice shall be given to concern parties to avoid danger to people, materials and nearby structures. All the damages caused by careless blasting if any shall be made good by the contractor at his own expenses.

**ii) Excavation in Hard Rock by Chiseling and Wedging:** Where blasting is not permitted and if the Engineer-in-Charge so desires, the excavation shall be done by chiseling and wedging or any other agreed method.

**NOTE:** All the excavated hard rock obtained shall be stacked properly and neatly within the specified lead by the contractor as directed by the Engineer-in-Charge.

**4.6 EXCAVATION PARAMETERS:** The excavation under all classifications in areas in trenches or in pits shall be carried out systematically. Cutting shall be done from top to bottom and no underpinning or undercutting will be allowed. The bottom and sides of excavation shall be dressed to proper level, slopes, steps, camber etc. by removing high spots, and ramming thoroughly as directed by the Engineer-in-charge.

All the excavation shall be carried out strictly to the dimensions given in the drawing. The width shall generally be of the width of mud mat concrete and depth as shown in drawing or as directed by the Engineer-in-Charge, according to availability of the desired bearing capacity of soil below. Any excavation if taken below the specified depths and levels, the contractor shall at his own cost fill up such overcut to the specified level with cement concrete 1:4:8 in case of excavation in all types of soils and with cement concrete 1:2:4 in case of excavation in soft and hard rock.

After the excavation is completed, the contractor shall notify the Engineer-in-Charge to that effect and no further work shall be taken up until the Engineer-in-Charge has approved the depth and dimensions and also the nature of foundation materials. Levels and measurements shall also be recorded prior to taking up any further work.

#### **4.7 SHORING:**

Unless separately provided for in the schedule of quantities, the quoted rate for excavation shall include excavation of slopes to prevent falling in soil by providing and/or fixing, maintaining and removing of shoring, bracing etc. The contractor would be responsible for the design of shoring for proper retaining of sides of trenches, pits etc. with due consideration to the traffic, superimposed loads etc. Shoring shall be of sufficient strength to resist the pressure and ensure safety from slips and to prevent damage to work and property and injury to persons. It shall be removed as directed after items for which it is required are completed. Should the slips occur, the slipped material shall be removed and slope dressed to a modified stable slope. Removal of the slipped earth will not be measured for payment.

#### **4.8 DEWATERING:**

Unless specifically provided for as a separate item in the schedule of quantities, rate shall also include bailing or pumping out all water which may accumulate in the excavation during the progress of further works such as mud mat concrete, R.C. footings, shuttering etc. either due to seepage, springs, rain or any other cause and diverting surface flow by bunds or other means. Care shall be taken to



ensure that the water discharged sufficiently away from the foundations to keep it free from nuisance to other works in the neighborhood.

#### **4.9 DISPOSAL OF EXCAVATED MATERIALS:**

**a) ANTIQUITES:** Any finds of archaeological interest such as relics of antiquity, coins, fossils or other articles of value shall be delivered to the Engineer-in-Charge and shall be the property of the Government.

**b) USEFUL MATERIALS:** Any material obtained from the excavation which in the opinion of the Engineer-in-Charge is useful, shall be stacked separately in regular stacks as directed by the Engineer-in-Charge and shall be the property of the Government.

No material excavated from foundation trenches of whatever kind they may be are to be placed even temporarily nearer than about 3 m. from the outer edge of excavation. Discretion of the Engineer-in-Charge in such cases is final. All materials excavated will remain the property of the Department. Rate for excavation includes sorting out of the useful materials and stacking them separately as directed within the specific lead.

Materials suitable and useful for backfilling or other use shall be stacked in convenient place but not in such a way as to obstruct free movement of materials, workers and vehicles or encroach on the area required for constructional purposes. It shall be used to the extent required to completely backfill the structure to original ground level or other elevation shown on the plan or as directed by the Engineer-in-Charge. **Materials not useful in anyway shall be disposed off, levelled and compacted as directed by the Engineer-in-charge within a specified lead. The site shall be left clean of all debris and levelled on completion.**

#### **4.10 BACKFILLING IN SIDES OF FOUNDATIONS, PLINTH, UNDER FLOOR ETC.:**

The back filling shall be done after the concrete or masonry has fully set and shall be done in such a way as not to cause under-thrust on any part of the structure. Where suitable excavated material is to be used for back filling, it shall be brought from the place where it was temporarily deposited and shall be used in backfilling. The scope of work for back filling/filling in foundation, plinth, under floors etc. shall include filling for all the buildings covered under the contract. Surplus earth available from one building, if required, shall be used for backfilling/filling for other buildings also within the specified lead mentioned in the item.

All timber shoring and form work left in the trenches, pits, floors etc. shall be removed after their necessity ceases and trash of any sort shall be cleared out from the excavation. All the space between foundation masonry or concrete and the sides of excavation shall be backfilled to the original surface with approved materials in layers not exceeding 150 mm. in thickness, watered and well consolidated by means of rammers to at least 90% of the consolidation obtainable at optimum moisture content (Proctor density). Flooding with water for consolidation will not be allowed. Areas inaccessible to mechanical equipment such as areas adjacent to walls and columns etc. shall be tamped by hand rammer or by hand held power rammers to the required density. The backfill shall be uniform in character and free from large lumps, stones, shingle or boulder not larger than 75 mm. in any direction, salt, clods, organic or other foreign materials which might rot. The backfilling in plinth

and under floors shall be done in similar way in layers not exceeding 150 mm. thick and shall be well consolidated by means of mechanical or hand operated rammers as specified to achieve the required density.

Test to establish proper consolidation as required will be carried out by the Department at rates specified. Two tests per 50 sqm. will be taken to ascertain the proper consolidation. The cost of tests carried out will be recovered from the contractor's bill.

#### **4.11 FILLING IN PLINTH AND UNDER FLOORS:**

After the available suitable excavated materials are exhausted as backfilling, the contractor shall notify the Engineer-in-Charge, of the fact and levels taken jointly with Engineer-in-Charge. The earth, murrum, sand, gravel etc. or such materials suitable for filling proposed to be filled under floors and so mentioned in the item of schedule of quantities shall then be brought to site from approved locations and sources.

**i) Earth Filling:** The earth, soft murrum etc. so brought shall be filled up in layers of 15 cm depth, each layer being well watered and consolidated by approved hand or mechanical tampers or other suitable means to achieve the required density.

**ii) Gravel or Sand Filling:** Gravel if required to be filled under floors, shall be single washed gravel of approved quality and of size varying from 12 mm. to 20 mm. it shall be uniformly blinded with approved type of soil and/or sand to obtain full compaction. Gravel shall be filled in specified thickness and shall be well watered and rammed entirely to the satisfaction of the Engineer-in-Charge.

If sand is required to be filled under floors, it shall be clean, medium grained and free from impurities. The filled in sand shall be kept flooded with water for 24 hrs. to ensure maximum consolidation. Any temporary work required to maintain sand under flooded condition shall be done by the contractor at his own cost. The surface shall then be well dressed and got approved from Engineer-in-Charge before any other work is taken over the fill.

#### **4.12 LEAD & LIFT**

**LEAD:** The lead for disposal/deposition of excavated materials shall be as specified in the respective item of work. For the purpose of measurements of lead, the area to be excavated or filled or area on which excavated material is to be deposited/disposed off shall be divided in suitable blocks and for each of the block, the distance between center lines shall be taken as the lead which shall be measured by the shortest straight line route on the plan and not the actual route adopted.

**LIFT:** Lift shall be measured from ground level. Excavation up to 1.5 m depth below ground level and depositing excavated material on the ground shall be included in the item of earthwork for various kinds of soil. Extra lift shall be measured in unit of 1.5 m or part thereof. Obvious lift shall only be measured; that is lifts inherent in the lead due to ground slope shall not be measured except for lead up to 250 m. All excavation shall be measured in successive stages of 1.5 m stating the commencing level. This shall not apply to cases where no lift is involved as in hill side cutting.

#### **4.13 MODE OF MEASUREMENTS:**

**4.13.1** All excavation in areas having depth more than 30 cm. pits, trenches etc. shall be measured

net. The dimensions for the purpose of payment shall be reckoned on the horizontal area of the excavation at the base for foundations of the walls, columns, footings, rafts or other foundations, multiplied by the mean depth from the surface of ground determined by levels. Excavation for side slopes will not be paid for. Excavation in areas having depths less than 30 cms. shall be measured as surface excavation on square meter basis, mentioning the average depth of excavation.

Reasonable working space beyond concrete dimensions shall be allowed for waterproofing and shuttering works in underground water tanks, sumps, septic tanks etc., where considered necessary in the opinion of the Engineer-in-Charge. However the same shall be limited to the following:

i) Waterproofing and shuttering works upto 2M depth	Maximum upto 600mm from wall face or 300mm from the edge of offset / raft, whichever is more.
ii) Waterproofing and shuttering works beyond 2M depth	Maximum upto 900mm from wall face or 300mm from the edge of offset / raft, whichever is more.

Reasonable working space beyond concrete dimension required for waterproofing and shuttering where considered necessary in the opinion of Engineer-in Charge will be allowed in execution and considered for payment for underground water tank, sump, septic tank etc.

**4.13.2** Wherever direct measurements of rock excavation are not possible, volume of rock be calculated on the basis of length, breadth and depth of stacks made at site. The net volume shall be worked out by reducing it by 50%, taking the voids into consideration as 50%. Similarly to arrive at net quantity to be paid in the case of soil, reduction @ 20% of corresponding stack/truck measurements shall be made.

**4.13.3 The rate for excavation shall include carting and disposing and leveling the excavated materials within the specified lead.** The rate shall also be inclusive of cost of all tools, plants, explosives, shoring, dewatering at various stages, labour, materials etc. to complete all the operations specified.

**4.13.4** The backfilling and consolidation in sides of foundation and in plinth with excavated material will not be paid for separately. The rate quoted for excavation shall be deemed to have been included the cost of stacking of excavated materials, conveying within the specified lead, picking of selected stacked materials, conveying it to the place of final backfill, compaction to the required proctor density etc.

**4.13.5** Payment for filling and consolidation inside the trenches, sides of foundations, plinth etc. with selected materials brought by the contractor other than the excavated material, shall be paid for separately as per the rates in schedule of quantities which includes cost of such materials/excavation, royalty, its conveyance within the specified lead, watering, consolidating, dressing etc. Actual quantity of consolidated filling shall be measured and paid in cubic meters up to two places of decimal.

**4.13.6** The rate quoted in cum. for items of excavation is deemed to include the necessary additional quantity of excavation involved beyond the plan dimensions of the work which may be necessary to be carried out for carrying out the work in an engineering manner, decided upon by the contractor. Therefore no extra payment will be made for any excavation done other than the required quantity as per the plan dimension indicated in the drawings.

**4.13.7** Measurements for excavation over areas shall be determined by levels or by “Dead men” or both at the discretion of the Engineer-in-Charge. If however the Engineer-in-Charge decides on measurement by levels, levels of site shall be jointly taken and recorded by the Engineer-in-Charge



or his representatives and the contractor, before commencement of the work and after completion of the work and the quantity of work done shall be computed based on these levels. The volume of earth work shall be computed based on “Simpson’s formula” or any other approved method at the discretion of the Engineer-in-Charge.

## **V. ANTITERMITE TREATMENT:**

### **5.1 GENERAL:**

Pre constructional anti-termite treatment is a process in which soil treatment is applied to a building in early stages of its construction. The purpose of anti-termite treatment is to provide the building with a chemical barrier against the subterranean termites.

Antitermite treatment being a specialized job, calls for thorough knowledge of the chemicals, soils, termite to be dealt with and the environmental conditions, in order to give effective treatment and lasting protection to the property undergoing treatment. It is, therefore, imperative that the works of anti-termite treatment should be got executed through specialized agencies only. The specialized agency should be preferably a member of the Indian Pest Control Association and shall have sufficient experience of carrying out similar works of magnitude envisaged in this tender.

The pre constructional soil treatment is required to be applied during the construction stages of the sub-structure up to plinth level. The contractor has to be watchful of the various stages of sub-structure works and arrange to carry out the soil treatment in time after proper co-ordination with Department and other contractors if any, working at site.

### **5.2 SCOPE:**

The scope of pre constructional anti-termite treatment covers the soil treatment with approved chemicals in water emulsion in foundation trenches for columns, plinth beams, pile caps, brick walls, service trenches, lift pits, steps, ramps etc. in top surfaces of plinth filling, at junction of walls and floor, in expansion joints etc. in stages as detailed in this specifications and drawings. Unless otherwise stipulated, the anti-termite treatment will be carried out as per I.S.6313 (part II) 1981 and/or as per direction of the Engineer-in-Charge.

### **5.3 SITE PREPARATION:**

In order to ensure uniform distribution of the chemical emulsion and to assist penetration, the following site preparation shall be carried out:

- a) Remove all trees, stumps, logs or roots from the building site.
- b) Remove all concrete form work if left anywhere, levelling pegs, timber off-cuts and other builders debris from the area to be treated.
- c) If the soil to be treated is sandy or porous, preliminary moistening will be required to fill capillary spaces in soil in order to prevent the loss of emulsion through piping or excessive percolations.
- d) In the event of water logging of foundation, the water shall be pumped out before application of chemical emulsion and it should be applied only when the soil is absorbent.
- e) On clays and other heavy soils where penetration is likely to be slow and on sloping sites, where run-off of the treating solution is likely to occur, the surface of the soil should be scarified to a depth of 75 mm. at least.
- f) All sub-floor levelling and grading should be completed, all cutting, trenches and excavations

should be completed with backfilling in place, borrowed fill must be free from organic debris and shall be well compacted. If this is not done supplementary treatments should be made to complete the barrier.

#### **5.4 CHEMICAL TO BE USED:**

The effectiveness of chemical depends upon the choice of the chemical, the dosage adopted and the thoroughness of application. The chemical solutions or emulsions are required to be dispersed uniformly in the soil and to the required strength so as to form an effective chemical barrier which is lethal and repellent to termites.

**Soil Treatment:** One of the approved chemicals in water emulsion, recommended by the Indian Pest Control Association (IPCA), and approved by the Engineer-in-Charge, shall be used uniformly over the area to be treated.

The contractor should produce voucher(s) for the chemical purchased and should get verified the sealed container(s) of the specified chemical from the Engineer-in-Charge before preparing the emulsion/use for the treatment.

#### **5.5 MODE AND RATE OF APPLICATION:**

The chemical emulsion as stated above will be applied uniformly by sprayers at the prescribed rates as detailed below in all the stages of the treatment.

**5.5.1 Treatment in Foundation Trenches:** In case of normal wall load bearing structures, column pits, wall trenches and basement, the treatment shall be @ 5 ltrs./sqm. of surface area of the bottom and sides to a height of atleast 300 mm. After the foundation work, the sides shall be treated @ 7.5 ltrs./sqm. of vertical surface of substructure on each side. After the earth filling is done, treatment shall be done by rodding the earth at 150 mm. centers close to wall surface and spraying the chemical with the above dose i.e. 7.5 ltrs./sqm.

In case of framed structure, the treatment shall start at a depth of 500 mm. below ground level. From this depth the backfill around the columns, beams and R.C.C. Basement walls shall be treated @ 7.5 ltrs./sqm. of the vertical surface and @ 5 ltrs./sqm. for the horizontal surface at the bottom in the trenches/pits.

**5.5.2 Treatment on Top Surfaces of Plinth Filling:** The top surface of the filled earth within plinth walls shall be treated with chemical emulsion at the rate of 5 litres/sqm. of the surface area before sub-base to floor is laid. If filled earth has been well rammed and the surface does not allow the emulsion to seep through, holes upto 50 to 75mm. deep at 150 mm. centers both ways shall be made with crow bars on the surface to facilitate saturation of the soil with the emulsion.

**5.5.3 Treatment at Junction of Walls and Floors:** Special care shall be taken to establish continuity of the vertical chemical barrier on the inner wall surfaces from the finished ground level (or from level where the treatment had stopped) upto the level of the filled earth surface. To achieved this a small channel 30 x 30 mm. shall be made at all the junctions of wall/column with floor (before laying sub-grade) and rod holes made in the channel upto the finished ground level at 150 mm apart and the iron rod moved backward and forward to break the earth and chemical emulsion poured along the channel @ 7.5 litres (or at recommended quantity) per sqm. of the vertical wall/column surfaces so

as to soak the soil right upto the bottom. The soil shall be tamped back into place after this operation.

**5.5.4 Treatment for Expansion Joints:** The soil beneath the expansion joints shall receive special attention when the treatment under 5.5.1 above is in progress. This treatment shall be supplemented by treating through the expansion joint after sub-grade has been laid at the rate of 2 litres per metre length of expansion joint.

**5.6 PRECAUTIONS DURING TREATMENT:**

- a) Utmost care shall be taken to see that the chemical barrier is complete and continuous. Each part of the area shall receive the prescribed dosage of chemical emulsion.
- b) The treatment should not be carried out when it is raining or when the soil is wet with rain or sub-soil water.
- c) Once formed, the treated soil barrier shall not be disturbed. If by chance, treated soil barriers are disturbed, immediate steps shall be taken to restore the continuity and completeness of the barrier system.

**5.7 PRECAUTIONS FOR HEALTH HAZARDS AND SAFETY MEASURES:**

**5.7.1** All the chemicals mentioned above are poisonous and hazardous to health. These chemicals can have an adverse effect upon health when absorbed through the skin, inhaled as vapours or spray mist or swallowed. Persons handling or using these chemicals should be warned of these dangers and advised that absorption through the skin is the most likely source of accidental poisoning. They should be cautioned to observe carefully the safety precautions given in 5.7.2 to 5.7.5 particularly when handling these chemicals in the form of concentrates

**5.7.2** These chemicals are usually brought to the site in the form of emulsifiable concentrates. The containers should be clearly labelled and should be stored carefully so that children and pets cannot get at them. They should be kept securely closed.

**5.7.3** Particular care should be taken to prevent skin contact with concentrates. Prolonged exposure to dilute emulsions should also be avoided. Workers should wear clean clothing and should wash thoroughly with soap and water especially before eating and smoking. In the event of severe contamination, clothing should be removed at once and the skin washed with soap and water. If chemicals splash into the eyes they shall be flushed with plenty of soap and water and immediate medical attention should be sought.

**5.7.4** The concentrates are oil solutions and present a fire hazard owing to the use of petroleum solvents. Flames should not be allowed during mixing.

**5.7.5** Care should be taken in the application of chemicals/soil-toxicants to see that they are not allowed to contaminate wells or springs which serve as source of drinking water.

**5.8 GUARANTEE:** The contractor has to furnish the guarantee for 10 (ten) years from the date of completion of work, stating that in case of reappearance of termites within the building area due to defective materials or workmanship or due to any other reasons, the contractor will carry out the necessary post constructional treatment to keep the entire area free from termite, once again, without any extra cost to the Department during the guarantee period.



**5.9 MODE OF MEASUREMENT:** The payment will be made on the basis of plinth area measurements at ground floor only for all the stages of treatment in sqm. correct to two places of decimals. Rate includes the cost of materials, labour and all tools, plants, sprayers required for complete operation.



---

## **VI. PLAIN / REINFORCED CONCRETE AND ALLIED WORKS:**

### **6.1 SCOPE:**

Scope of the specification deals with the structural and general use of plain and reinforced cement concrete. The specifications cover the qualitative and quantitative requirements in respect of selection of ingredients, proportioning, manufacture of concrete, transport, placing, consolidation, curing, finishing, acceptance criteria etc., these specifications also cover the requirement of form work and reinforcement.

**6.2** Unless otherwise specified, the manufacture and placing of concrete shall be done by weigh batching. However, in the specific cases where mechanized batching system (Ready mix concrete), mechanical transport and pumping is specified the same shall be followed as per the terms of the contract.

### **6.3 CEMENT CONCRETE (PLAIN AND REINFORCED):**

**6.3.1** The quality of materials, method, control of manufacture and transportation of all concrete work in respect of mix, whether reinforced or otherwise, shall conform to the applicable portions of these specifications.

**6.3.2 Mandatory tests:** The Engineer-in-Charge shall have the right to inspect the sources of materials, the layout and operation of procurement and storage of materials, the concrete batching and mixing equipment and the quality control system. The contractor shall arrange such an inspection and the Engineer-in-Charge approval shall be obtained prior to starting the concrete work. List of mandatory test for RCC to be carried out.

**6.3.3 Materials for Standard Concrete:** The ingredients to be used in the manufacture of standard concrete shall consist solely of a standard type Portland/Portland pozzolana cement, clean sand, natural coarse aggregate, clean water, ice and admixtures if specially called for on drawings or schedule of quantities.

**6.3.3.1. Cement:** Unless otherwise specified or called for in the contract specifications, cement shall be any of the following and the type selected should be appropriate for the intended use and as per the contract conditions, specifications and drawings.

- a) 33 Grade Ordinary Portland cement conforming to IS 269
- b) 43 Grade ordinary Portland cement conforming to IS 8112
- c) 53 Grade ordinary Portland Cement conforming to IS 12269
- d) Portland slag cement conforming to IS 455.
- e) Portland pozzolana cement (fly ash based ) conforming to IS 1489 (Part I)
- f) *Portland pozzolona cement (calcined clay based* conforming to IS 1489 (Part 2)
- g) Sulphate resisting Portland cement conforming to IS 12330.

In case the job requires specific use of any of the following cements the same shall be used

with the prior approval of the EIC and necessary precautions with regard to their setting and hardening time, time required for de-shuttering, curing etc., shall be taken after carefully complying with specific literature with regard to those types.

1. High Alumina cement - conforming to IS 6452
2. Low heat cement - conforming to IS 12600
3. Super sulphate cement - conforming to IS 6909
4. Rapid Hardening cement - conforming to IS 8041
5. Blended Cement for finishing work as below

Other combinations of Portland Cement with mineral admixtures of quality conforming to relevant Indian Standards laid down may also be used in the manufacture of concrete provided that there are satisfactory data on their suitability, such as performance test on concrete containing them and only in such case where in specifically called for in the contract.

#### **6.3.3.1 (A). Mineral Admixtures**

**Pozzolana:** Pozzolanic materials conforming to relevant Indian Standards may be used with the permission of Engineer-in-charge, provided uniform blending with cement is ensured.

**Fly ash (pulverized fuel ash):** Fly ash conforming to Grade 1 of IS 3812 may be used as part replacement of ordinary Portland cement provided uniform blending with cement is ensured.

**Silica fume:** Silica fume conforming to a standard approved by the deciding authority can be used as part replacement of cement provided uniform blending with the cement is ensured.

**Note:** The silica fume (very fine non –crystalline silicon dioxide) is a by-product of the manufacture of silicon, ferrosilicon or the like, from quartz and carbon in electric arc furnace. It is usually used in proportion of 5 to 10 percent of the cement content of a mix.

**Rice husk ash:** Rice husk ash giving required performance and uniformity characteristics may be used with the approval of the deciding authority.

**Note:** Rice husk ash is produced by burning rice husk and contain large proportion of silica. To achieve amorphous state, rice husk may be burnt at controlled temperature. It is necessary to evaluate the product from a particular source for performance and uniformity since it can range from being as deleterious as silt when incorporated in concrete. Water demand and drying shrinkage should be studied before using rice husk.

**Metakaolin:** Metakaolin having fineness between 700 to 900m<sup>2</sup>/kg may be used as pozzolanic material in concrete.

**Note:** Metakaolin is obtained by calcination of pure or refined kaolintic clay at a temperature between 650°C and 850°C, followed by grinding to achieve a fineness of 700 to 900 m<sup>2</sup>/kg. The resulting material has high pozzolanicity.

**Ground Granulated Blast Furnace Slag:** Ground granulated blast Furnace slag obtained by grinding granulated blast furnace slag conforming to IS 12089 may be used as part replacement of ordinary Portland cement provided uniform blending with cement is assured.

A certified report attesting to the conformity of the cement to I.S. specifications by the cement manufacturer's chemist shall be furnished to the Engineer-in-Charge, if demanded. The Contractor, shall make his own arrangements for the storage of adequate quantity of cement at no extra cost at the site of work as per instructions and approval of the Engineer-in-Charge.

**Specification for Storage:**

Cement in bags shall be stored and stacked in a shed, which is dry, leak-proof and moisture proof as far as possible. Storage under tarpaulins will not be permitted. Flooring of the shed shall consist of the two layers of dry bricks laid on well consolidated earth to avoid contact of cement bags with the floor. Stacking shall be done about 150 to 200 mm clear above the floor using wooden planks. Cement bags shall be stacked at least 450 mm clear off the walls and in rows of two bags leaving in a space of at least 600 mm between two consecutive rows. In each row the cement bags shall be kept closed together so as to reduce air circulation. Stacking shall not be more than ten bags high to avoid lumping under pressure. In stacks more than eight bags high, the cement bags shall be arranged in header and stretcher fashion i.e alternately lengthwise and crosswise so as to tie the stacks together and minimize the danger of toppling over.

Damaged or reclaimed or partly set cement will not be permitted to be used and shall be removed from the site. The storage arrangements shall be such that there is no dead storage consignments in cement shall be stored as received and shall be consumed in the order of their delivery.

Cement held in store for a period of ninety (90) days or longer shall be retested before use in work. Should at any time the Engineer-in-Charge have reasons to consider that any cement is defective, then irrespective of its origin and/or manufacturers test certificate, such cement shall be tested immediately at a National Test Laboratory/Departmental Laboratory or such approved laboratory, and until the results of such tests are found satisfactory, it shall not be used in any work.

**6.3.3.2 Aggregates:**

- a) **"Aggregate"** in general designates both fine and coarse inert materials used in the manufacture of concrete.
- b) **"Fine Aggregate"** is aggregate most of which passes through 4.75 mm I.S. sieve.
- c) **"Coarse Aggregate"** is aggregate most of which is retained on 4.75 mm I.S. sieve. Aggregate shall comply with requirement of IS 383. As far as possible preference shall be given to machine broken and graded aggregate.

All fine and coarse aggregates proposed for use in the work shall be subject to the Engineer-in-Charge approval and after specific materials have been accepted, the source of supply of such materials shall not be changed without prior approval of the Engineer-in-Charge.

Aggregate shall, except as noted above, consist of natural sand, crushed stone and gravel from a source known to produce satisfactory aggregate for concrete and shall be chemically inert, strong, hard, durable against weathering, of limited porosity and free from deleterious materials that may cause corrosion to the reinforcement or may impair the strength and/or durability of concrete. The grading of aggregates shall be such as to produce a dense concrete of specified strength and consistency that will work readily into position without segregation and shall be based on the "mix design" and preliminary test on concrete specified herein-after.

**Sampling and testing:** Sampling of the aggregates for mix design and determination of suitability shall be taken under the supervision of the Engineer-in-Charge and delivered to the laboratory, well in advance of the schedule for placing of concrete. Records of tests which have been made on proposed aggregates and on concrete made from this source of aggregates shall be furnished to the Engineer-in-Charge in advance of the work for use, in determining suitability of the proposed aggregate.

**Storage of aggregates:** All coarse and fine aggregates shall be stacked separately in stock piles in the material yard near the work site in bins properly constructed to avoid inter mixing of different aggregates. Contamination with foreign materials and earth during storage and while heaping the materials shall be avoided. The aggregate must be of specified quality not only at the time of receiving at site but also at the time of loading into mixer. Rakers shall be used for lifting the coarse aggregate from bins or stock piles. Coarse aggregate shall be piled in layers not exceeding 1.00 metres in height to prevent conning or segregation. Each layer shall cover the entire area of the stock pile before succeeding layers are started. Aggregates that have become segregated shall be rejected. Rejected material after re-mixing may be accepted, if subsequent tests demonstrate conformity with required gradation.

**Specific Gravity:** Aggregates having a specific gravity below 2.6 (saturated surface dry basis) shall not be used without special permission of the Engineer-in-Charge.

**6.3.3.2.1 Fine Aggregate:** Fine aggregate except as noted above, and for other than light weight concrete shall consist of natural or crushed sand conforming to I.S. 383. The sand shall be clean, sharp, hard, strong and durable and shall be free from dust, vegetable substances, adherent coating, clay, loam, alkali, organic matter, mica, salt or other deleterious substances which can be injurious to the setting qualities/strength/durability of concrete.

**6.3.3.2.2 Machine Made Sand:** Machine made sand will be acceptable, provided the constituent rock composition is sound, hard, dense, non-organic, uncoated and durable against weathering. Machine made sand shall be accepted provided grading & finer particle limits conform to IS 383.

**6.3.3.2.3 Screening and Washing:** Sand shall be prepared for use by such screening or washing or both, as necessary, to remove all objectionable foreign matter while separating the sand grains to the required size fractions. Sand with silt content more than 3 percent will not be permitted to be used unless the same is washed and silt content is brought within 3% by weight.

**Foreign Material Limitations:** The percentages of deleterious substances in sand,

delivered to the mixer shall not exceed the following:

Sl. No	Substances	Percent by weight	
		Uncrushed	Crushed
i)	Material finer than 75 micron I.S. Sieve	3.00	15.00
ii)	Shale	1.00	--
iii)	Coal and lignite	1.00	1.00
iv)	Clay lumps	1.00	1.00
v)	Total of all above substances including items (i) to (iv) for uncrushed sand and items (iii) and (iv) for crushed sand.	5.00	2.00

**GRADATION:** Unless otherwise directed or approved, the grading of sand shall be within the limits indicated hereunder.

I.S. Sieve Designation	Percentage passing for			
	Grading Zone -I	Grading Zone -II	Grading Zone -III	Grading Zone -IV
9.5 mm	100	100	100	100
4.75mm	90-100	90-100	90-100	95-100
2.36mm	60-95	75-100	85-100	95-100
1.18 mm	30-70	55-90	75-100	90-100
600 micron	15-34	35-59	60-79	80-100
300 micron	5-20	8-30	8-30	20-65
150 micron	0-10	0-10	0-10	0-15

Where the grading falls outside the limits of any particular grading zone of sieves, other than 600 micron (I.S.) sieve by not more than 5%, it shall be regarded as falling within that grading zone. This tolerance shall not be applied to percentage passing the 600 micron (I.S.) sieve or to percentage passing any other sieve size on the coarser limit of grading zone I or the finer limit of grading zone IV. Fine aggregates conforming to Grading Zone IV shall not be used unless mix designs and preliminary tests have shown its suitability for producing concrete of specified strength and workability.

**Fineness Modulus:** The sand shall have a fineness modulus of not less than 2.2 or more than 3.2.

The fineness modulus is determined by adding the cumulative percentages retained on the following I.S. sieve sizes (4.75 mm, 2.36 mm, 1.18 mm, 600 micron, 300 micron and 150 micron) and dividing the sum by 100.

**6.3.3.2.4 Coarse Aggregate:** Coarse aggregate for concrete, except as noted above and for other than light weight concrete shall conform to I.S. 383. This shall consist of natural or crushed stone and gravel, and shall be clean and free from elongated, flaky or laminated pieces, adhering coatings, clay lumps, coal residue, clinkers, sag, alkali, mica, organic matter or other deleterious matter.

The coarse aggregate and fine aggregate shall be tested from time to time as required by the Engineer-in-Charge to ascertain its suitability for use in construction and the charges for testing aggregate shall be born by the contractor as specified herein after.

**Screening and Washing:** Crushed rock shall be screened and/or washed for the removal of dirt or dust coating, if so demanded by Engineer-in-Charge.

**Grading:** Coarse aggregates shall be either in single or graded, in both the cases. The grading shall be within the following limits:

I.S. Sieve Designation	Percentage passing for single sized aggregates of nominal size						Percentage passing for graded aggregates of nominal size			
	63 mm	40 mm	20 mm	16mm	12.5mm	10 mm	40 mm	20 mm	16 mm	12.5 mm
75 mm	100	-	-	-	-	-	-	-	-	-
53 mm	85-100	100	-	-	-	-	100	-	-	-
37.5 mm	0-30	85-100	100	-	-	-	95-100	100	-	-
19 mm	0-5	0-20	85-100	100	-	-	30-70	95-100	100	100
13.2 mm	-	-	-	85-100	100	-	-	-	90-100	-
11.2 mm	-	-	-	-	85-100	100	-	-	-	90-100
9.5 mm	-	0-5	0-20	0-30	0-45	85-100	10-35	25-55	30-70	40-85
4.75 mm	-	0-5	0-5	0-10	0-20	0-20	0-5	0-10	0-10	0-10
2.36 mm	-	-	-	-	0-5	0-5	-	-	-	-

The pieces shall be angular in shape and shall have granular or crystalline surfaces. Friable, flaky and laminated pieces, mica and shale, if present, shall be only in such quantities that will not, in the opinion of Engineer-in-Charge, affect adversely the strength and/or durability of concrete, the maximum size of coarse aggregate shall be the maximum size specified above, but in no case greater

than 1/4 of the minimum thickness of the member, provided that the concrete can be placed without difficulty so as to surround all reinforcement thoroughly and fill the corners of form. Plums above 160 mm. and up to any reasonable size can be used in plain mass concrete work of large dimensions up to a maximum limit of 20% by volume of concrete when specifically approved by Engineer-in-Charge. For heavily reinforced concrete members, the nominal maximum size of the aggregate shall be 5 mm. less than the minimum clear distance between the reinforcing main bars or 5mm less than the minimum cover to the reinforcement whichever is smaller. The amount of fine particles occurring in the Free State or as loose adherent shall not exceed 1% when determined by laboratory sedimentation tests as per I.S. 2386. After 24 hours immersion in water, a previously dried sample shall not have gained more than 10% of its oven dry weight in air, as determined by I.S.2386.

**Foreign Material Limitations:** The percentages of deleterious substances in the coarse aggregate delivered to the mixer shall not exceed the following:

Sl.No	Substances	Percentage by weight of aggregates	
		Uncrushed	Crushed
i)	Material finer than 75 micron I.S. Sieve	3.00	3.00
ii)	Coal and lignite	1.00	1.00
iii)	Clay lumps	1.00	1.00
iv)	Soft fragments	3.00	--
v)	Total of all the above substances	5.00	5.00

#### **6.3.3.3 WATER:**

Water used for both mixing and curing shall be clean and free from injurious amounts of deleterious materials. viz oils, acids, alkalis, salts, sugar, organic materials or other substances that may be deleterious to concrete or steel. Potable waters are generally satisfactory for mixing and curing concrete. In case of doubt, the suitability of water for making concrete shall be ascertained by the compressive strength and initial setting time test specified in I.S. 456-2000. The sample of water taken for testing shall be typical of the water proposed to be used for concreting, due account being paid to seasonal variation. The samples shall not receive any treatment before testing other than that envisaged in the regular supply of water proposed for use in concrete. The sample shall be stored in a clean container previously rinsed out with similar water.

Average 28 days compressive strength of at least three 150 mm. concrete cubes prepared with water proposed to be used shall not be less than 90% of the average strength of three similar concrete cubes prepared with distilled water as per IS - 516.

The initial setting time of test block made with the appropriate cement and the water proposed to be used shall not be less than 30 minutes and shall not differ by more than (+/-) 30 minutes from the initial setting time of control test block prepared with the same cement and distilled water. The test blocks shall be prepared and tested in accordance with the requirements of I.S. 4031(Part 5).

Where water can be shown to contain an excess of acid, alkali, sugar or salt, Engineer-in-Charge may refuse to permit its use. As a guide, the following concentrations represent the maximum permissible values:

**a) Limits of acidity:** To neutralize 100 ml sample of water, using phenolphthalein as an indicator, it should not require more than 5 ml. of 0.02 normal NaOH. The details of test shall be as per I.S. 3025 (Part 22)

**b) Limits of alkalinity:** To neutralize 100 ml sample of water, using mixed indicator, it should not require more than 25 ml. of 0.02 normal H<sub>2</sub>SO<sub>4</sub>. The details of test shall be as per I.S. 3025 (Part 23).

**c) Permissible limits for solids shall be as under (water):**

Sl.No.	Type of solid	Tested as per	Permissible limit (Max.)
i)	Organic	IS 3025 (Part 18)	200 mg / l
ii)	Inorganic	IS 3025 (Part 18)	3000 mg / l
iii)	Sulphates (as SO <sub>2</sub> )	IS 3025 (Part 24)	400 mg / l
iv)	Chlorides (asCl)	IS 3025 (Part 32)	2000 mg / l for concrete not containing embedded steel and 500 mg/l for reinforced cement concrete work.
v)	Suspended matter	IS 3025 (Part 17)	2000mg / l

**d) The PH value of water shall be not less than 6.**

#### **6.4 DESIGN MIX CONCRETE:**

All reinforced concrete in the works shall be "Design Mix Concrete" as defined in I.S. 456-2000.

**6.4.1 Mix Design:** This is to investigate the grading of aggregates, water cement ratio, workability and the quantity of cement required to give works cubes of the characteristic strength specified. The proportions of the mix shall be determined by weight. Adjustment of aggregate proportions due to moisture present in the aggregate shall be made. Mix proportioning shall be carried out according to the ACI standard designation ACI- 613 or Design of concrete mixes - Road research Note No.4, Department of Scientific and Industrial Research U.K. or I.S. 10262 - 1982.

After award of the work, if so desired by the contractor, he/they may be allowed by the Engineer-in-Charge, till the designed mix is obtained, to carry out the reinforced concrete work in foundation and plinth as per equivalent nominal mix against the specified design mix concrete as per I.S. Codes. However, all other specification for design mix shall govern for nominal mix also and nothing extra shall be paid for use of extra cement or else on this account whether the cement is supplied by the Department or procured by the contractor. Where the quantity of RCC is very small, under such circumstance equivalent nominal mix can also be permitted by the Engineer-in-Charge.



**GRADES OF CONCRETE: The concrete shall be in grades designated as below.**

Group	Grade Designation	Specified Characteristic compressive strength of 150 mm cube at 28 days (N/mm <sup>2</sup> )
Ordinary concrete	M 10	10
	M 15	15
	M 20	20
Standard Concrete	M 25	25
	M 30	30
	M 35	35
	M 40	40
	M 45	45
	M 50	50
	M 55	55
High strength concrete	M 60	60
	M 65	65
	M 70	70
	M 75	75
	M 80	80

**NOTE:** 1. The characteristic strength is defined as the strength of material below which not more than 5% of the test results are expected to fall.

2: In the designation of a concrete mix, letter "M" refers to the mix and the number to the specified characteristic compressive strength of 150 mm. size cubes at 28 days expressed in N/ mm<sup>2</sup>.

3. Minimum Cement Content, Maximum Water Cement Ratio and Minimum Grade of Concrete for Different Exposures with Normal Weight Aggregates of 20 mm Nominal Maximum size.

Sl No.	Exposure	Plain concrete			Reinforced concrete		
		Minimum cement content Kg/m <sup>3</sup>	Maximum Free Water Cement Ratio	Minimum grade of concrete	Minimum Cement Content Kg/m <sup>3</sup>	Maximum Free Water Cement Ratio	Minimum Grade of concrete
(1)	(2)	(3)	(4)	(5)	(6)	(7)	(8)
i)	Mild	220	0.60	-	300	0.55	M-20
ii)	Moderate	240	0.60	M-15	300	0.50	M-25
iii)	Severe	250	0.50	M-20	320	0.45	M-30
iv)	Very	260	0.45	M-20	340	0.45	M-35

	severe						
v)	Extreme	280	0.40	M-25	360	0.40	M-40

**NOTE:**

1. Cement content prescribed in this table is irrespective of the grades of cement and it is inclusive of additions mentioned in mineral admixtures. The additions such as fly ash or ground granulated blast furnace slag may be taken into account in the concrete composition with respect to the cement content and water-cement ratio if the suitability is established and as long as the maximum amounts taken into account do not exceed the limit of pozzolona and slag specified in IS 1489 (Part 1) and IS 455 respectively.
2. Minimum grade for plain concrete under mild exposure condition is not specified.

**Nominal cover to meet Durability Requirements**

Exposure	Nominal concrete cover in mm not less than
Mild	20
Moderate	30
Severe	45
Very severe	50
Extreme	75

**NOTE:**

3. For main reinforcement up to 12 mm diameter bar for mild exposure the nominal cover may be reduced by 5 mm.
4. Unless specified otherwise, actual concrete cover should not deviate from the required nominal cover by + 10 mm
5. For exposure conditions 'severe' and 'very severe', reduction of 5 mm may be made, where concrete grade is M 35 and above.

**Nominal cover to meet specified period of fire resistance**

Fire resistance	Nominal cover						
	beams		slabs		ribs		columns
	Simply Supported	Continuous	Simply Supported	Continuou s	Simply Supported	Continuous	
H	mm	mm	mm	mm	mm	mm	mm
0.5	20	20	20	20	20	20	40
1	20	20	20	20	20	20	40
1.5	20	20	25	20	35	20	40
2	40	30	35	25	45	35	40
3	60	40	45	35	55	45	40
4	70	50	55	45	65	55	40

**NOTE:**

- 1 The nominal covers given relate specifically to the minimum member dimensions as per drawing
- 2 Cases that lie below the bold line require attention to the additional measures necessary to reduce the risks of spilling.

Adjustments to Minimum cement contents for Aggregates other than 20 mm Nominal Maximum size:

Sl. No	Nominal maximum Aggregate size mm	Adjustments to Minimum cement content kg/ m <sup>3</sup>
(1)	(2)	(3)
i)	10	+40
ii)	20	0
iii)	40	-30

For concrete of compressive strength greater than M55 design parameters given in the standard may not be applicable and the values may be obtained from specialized Literatures and experimental results.

The mix shall be designed to produce the grade of concrete having the required workability and characteristic strength not less than appropriate values given in the table above.

**DEGREE OF CONTROL:**

**Selection of Water Cement Ratio:** Since different cements and aggregates of different maximum size, grading, surface texture, shape and other characteristics may produce concretes of different compressive strength for the same free water cement ratio, the relationship between strength and free water-cement ratio should preferably be established for the materials actually to be used. In the absence of such data, the preliminary free water-cement ratio (by mass) corresponding to the target strength at 28 days may be selected from the relationship shown in Fig.1 of I.S. 10262.

Alternately, the preliminary free water cement ratio (by mass) corresponding to the target average strength may be selected from the relationship in Fig.2- I.S. 10262, using the curve corresponding to the 28 days cement strength to be used for the purpose.

Other relevant items to be used with design of mix should strictly conform to the relevant clauses and appendices of I.S. 10262.

The calculated mix proportions shall be checked by means of trial batches as per IS 10262

The free water cement ratio selected as above, should be checked against the limiting water cement ratio for the requirement of durability and the lower of the two values should be adopted.

Whenever there is a change either in required strength of concrete or water cement ratio or workability or the source of aggregates and/or cement, fresh tests shall be carried out to determine the revised proportion of the mix to suit the altered conditions. While designing mix proportions, over wet mixes shall always be avoided.

While fixing the value for water cement ratio for Design Mix assistance may be derived from the standard graph showing the relationship between the 28 days compressive strength of concrete mixes with different water-cement ratios and the 7 days compressive strength of cement tested in accordance with I.S.269.

It will be contractors sole responsibility to establish the concrete mix designs for different grades of concrete specified in the work consistent with the workability required for nature of work and also taking into consideration the assumed standard deviation which will be expected at site or by establishing the standard deviation based on 30 test results at site for each grade of concrete so as to produce concrete of required strength, durability and surface finish. The materials and proportions used in making the tests to be carried out either at site or under laboratory, conditions shall be similar in all respects to those to be actually employed in the works, as the object of these tests is to determine the proportions of cement, aggregates and water necessary to produce the concrete of the required consistency to give such specified strength.

#### **6.4.2: STANDARD DEVIATION:**

The standard Deviation for each grade of concrete shall be calculated separately

#### **STANDARD DEVIATION BASED ON TEST RESULTS:**

**a) Number of test results** - The total number of test results required to constitute and acceptable record for calculation of standard deviation shall be not less than 30. Attempts should be made to obtain the 30 test results, as early as possible, when a mix is used for the first time.

**b) Standard deviation to be brought up to date** - The calculation of the standard deviation shall be brought up to date after every change of mix design and at least once a month.

#### **Determination of standard deviation:**

i) Concrete of each grade shall be analyzed separately to determine its standard deviation.

The standard deviation of concrete of a given grade shall be calculated using the following formula from the results of individual tests of concrete of that grade obtained as specified for test strength of sample:

ii) Estimated standard **deviation**  $S = \sqrt{\{\Sigma \Delta^2 \div (n-1)\}}$

iii) Where  $\Delta$  = Deviation of the individual test strength from the average strength of a sample and

n = Number of sample test results.

c) When significant changes are made in the production of concrete (for example changes in the materials used, mix design, equipments or technical control), the standard deviation value shall be separately calculated for such batches of concrete.

**d) Assumed Standard Deviation:**

Where sufficient test results for a particular grade of concrete are not available, the value of standard deviation given in table below may be assumed for design of mix in the first instance. As soon as the results of samples are available, actual calculated standard deviation shall be used and the mix designed properly. However, when adequate past records for a similar grade exist and justify to the designer a value of standard deviation different from that shown in table below, it shall be permissible to use that value.

<b>Grade of Concrete</b>	<b>Assumed Standard Deviation N/ mm<sup>2</sup></b>
M 10 M 15	3.5
M 20 M25	4.0
M30 M35 M40 M45 M50	5.0

**Note:** The above values correspond to the site control having proper storage of cement: weigh batching of all materials: controlled addition of water: regular checking of all materials: aggregate grading and moisture contents: and periodical checking of workability: and strength. Where there is deviation from the above the values given in the above table shall be increased by 1 N / mm.<sup>2</sup>

**6.4.3 Proportioning, Consistency, Batching and Mixing of Concrete:**

**6.4.3.1 Proportioning:**

**Aggregate:** The proportions which shall be decided by conducting preliminary tests shall be by weight. These proportions of cement, fine and coarse aggregates shall be maintained during subsequent concrete batching by means of weigh batchers conforming to I.S. 2722, capable of controlling the weights within one percent of the desired value. Except where it can be shown to the satisfaction of the Engineer-in-Charge that supply of properly graded aggregate of uniform quality can be maintained over the period of work, the grading of aggregate shall be controlled by obtaining the coarse aggregate in different sizes and blending them in the right proportions. The different sizes shall be stacked in separate stock piles. The grading of coarse and fine aggregates shall be checked as frequently as possible, as determined by the Engineer-in-Charge, to ensure maintaining of grading in accordance with samples used in preliminary mix design. The materials shall be stock piled well in advance of use.

**Cement:** The cement shall be measured by weight. Every facility should be provided to the Engineer-in-Charge for sampling and inspection of stored cement at site of work.

Exposure conditions:

**General environment:**

Sl. No:	Environment	Exposure Conditions
(1)	(2)	(3)
i)	Mild	Concrete surfaces protected against weather or aggressive conditions, except those situated in coastal area.
ii)	Moderate	Concrete surfaces sheltered from severe rain or freezing whilst wet Concrete exposed to condensation and rain Concrete continuously under water Concrete in contact or buried under non-aggressive soil/ground water Concrete surfaces sheltered from saturated salt air in coastal area
iii)	Severe	Concrete surfaces exposed to severe rain, alternate wetting and drying or occasional freezing whilst wet or severe condensation. Concrete completely immersed in sea water Concrete exposed to coastal environment.
iv)	Very severe	Concrete surfaces exposed to seawater spray, corrosive fumes or severe freezing conditions whilst wet. Concrete in contact with or buried under aggressive sub-soil/ground water.
v)	Extreme	Surface of members in tidal zone Members in direct contact with liquid/solid aggressive chemicals.

**WATER:** Only such quantity of water shall be added to the cement and aggregate in the concrete mix as to ensure dense concrete, specified surface finish, satisfactory workability, consistent with strength stipulated for each class of concrete. The water added to the mix shall be such as not to cause segregation of materials or the collection of excessive free water on the surface of the concrete.

**Definition of water cement ratio:** The water cement (W/C) ratio is defined as the weight of water in mix (including the surface moisture of the aggregates) divided by the weight of the cement in the mix.

**Water cement ratio:** The actual water cement ratio to be adopted shall be determined in each instance by contractor and approved by the Engineer-in-charge.

**Proportioning by water-cement ratio:** The W/C ratio specified for use by the Engineer-in-Charge shall be maintained. Contractor shall determine the water content of the aggregate as frequently as directed by the Engineer-in-Charge as the work progresses and as specified in I.S. 2386 part III and the amount of mixing water added at the mixer shall be adjusted as directed by the Engineer-in-charge so as to maintain the specified W/C ratio. To allow for the variation in their moisture content,

suitable adjustments in the weights of aggregates shall also be made.

**6.4.3.2 Consistency and slump:** Concrete shall be of a consistency and workability suitable for the conditions of the job. After the amount of water required is determined, the consistency of mix shall be maintained throughout the progress of the corresponding parts of the work and approved tests e.g. slump tests, compacting factor tests etc. in accordance with I.S. 1199, shall be conducted from time to time to ensure the maintenance of such consistency.

The following tabulation gives a range of workability which shall generally be used for various types of construction unless otherwise instructed by the Engineer-in-Charge.

**Workability of concrete:**

<i>Placing condition</i>	<i>Degree of workability</i>	<i>Slump (mm)</i>
(1)	(2)	(3)
Blinding Concrete; Shallow Sections; Pavement using pavers	<i>Very low</i>	See note1.
Mass concrete; Lightly reinforced Sections in slabs, Beams, walls, columns; Floors; Hand placed pavements; Canal lining; Strip footings	<i>Low</i>	25-75
Heavily Reinforced sections In slabs, beams, walls, columns, slip form work; pumped concrete	Medium	50-100 75-100
Trench fill, In-situ piling	<b>High</b>	100-150
Tremie Concrete	<b>Very High</b>	See note 2.

**Note:** 1: For most of the placing conditions, internal vibrators (needle vibrators) are suitable. The diameter of the needle shall be determined based on the density and spacing of reinforcement bars and thickness of sections. For tremie concrete, vibrators are not required to be used.

2: the 'very low' category of workability where strict control is necessary, for example pavement quality concrete, measurement of workability by determination of compacting factor will be more appropriate than slump (see IS 1199) and a value of compacting factor of 0.75 to 0.80 is suggested.

3: In the 'Very high' category of workability, measurement of workability by determination of flow will be appropriate (see IS 9103).

**PRODUCTION OF CONCRETE:**

**QUALITY ASSURANCE MEASURES:**

In order that the properties of the completed structure be consistent with the requirements and the assumptions made during the planning and the design, adequate quality assurance

measures shall be taken. The construction should result in satisfactory strength, serviceability and long term durability so as to lower the overall life-cycle cost. Quality assurance in construction activity relates to proper design use of adequate materials and components to be supplied by the producers, proper workmanship in the execution of works by the contractor and ultimately proper care during the use of structure including timely maintenance and repair by the owner.

Quality assurance measures are both technical and organizational. Some common cases should be specified in a general Quality Assurance Plan which shall identify the key elements necessary to provide fitness of the structure and the means by which they are to be provided and measured with the overall purpose to provide confidence that the realized project will work satisfactorily in service fulfilling intended needs. The job of quality control and quality assurance would involve quality audit of both the inputs as well as the outputs. Inputs are in the form of materials for concrete; workmanship in all stages of batching, mixing, transportation; placing, compaction and curing; and the related plant, machinery and equipments; resulting in the output in the form of concrete in place. To ensure proper performance, it is necessary that each step in concreting which will be covered by the next step is inspected as the work proceeds.

Each party involved in the realization of a project should establish and implement a Quality Assurance Plan, for its participation the project. Suppliers and contractors activities shall be covered in the plan. The individual quality assurance plans shall fit into the general Quality Assurance Plan. A quality assurance plan shall define the tasks and responsibilities of all person involved, adequate control and checking procedures, and the organization maintaining adequate documentation of building process and its results. Such documentation should generally include:

- a) test reports and manufacturers certificate for materials, concrete mix design details;
- b) pour cards for site organization and clearance for concrete placement;
- c) record of site inspection of workmanship, field tests
- d) non-conformance reports, change orders;
- e) quality control charts;
- f) Statistical analysis.

**NOTE:** Quality control charts are recommended wherever the concrete is in continuous production over considerable period.

#### **6.4.3.3 Batching and mixing of concrete:**

##### **BATCHING**

To avoid confusion and error in batching, consideration should be given to using the smallest practical number of different concrete mixes on any site or in any one plant. In batching concrete, the quantity of both cement and aggregate shall be determined by mass; admixture, if solid, by mass; liquid admixture may however be measured in volume or mass; water shall be weighed or measured by volume in a calibrated tank (see also IS 4925)



---

Ready mixed concrete supplied by ready-mixed concrete plant shall be preferred. For large and medium project sites the concrete shall be sourced from ready-mixed concrete plants or from on site or off site batching and mixing plants (see IS 4926)

Except where it can be shown to the satisfaction of the engineer-in-charge that supply of properly graded aggregate of uniform quality can be maintained over a period of work, the grading of aggregate should be controlled by obtaining the coarse aggregate in different sizes and blending them in the right proportions when required, the different sizes being stocked in separate stock – piles. The material should be stock-piled for several hours preferably a day before use. The grading of coarse and fine aggregate should be checked as frequently as possible, the frequency for a given job being determined by the engineer-in-charge to ensure that the specified grading is maintained.

The accuracy of the measuring equipment shall be within +/- 2 % of the quantity of cement being measured and within +/- 3 percent of the quantity of aggregate, admixtures and water being measured.

Proportion / Type and grading of aggregate shall be made by trial in such a way so as to obtain densest possible concrete. All ingredients of the concrete should be used by mass only.

Volume batching may be allowed only where weigh-batching is not practical and provided accurate bulk densities of materials to be actually used in concrete have earlier been established. Allowance for bulking shall be made in accordance with IS 2386 (Part 3). The mass volume relationship should be checked as frequently as necessary, the frequency for the given job being determined by engineer-in-charge to ensure that the specified grading is maintained.

It is important to maintain the water-cement ratio constant at its correct value. To this end determination of moisture contents in both fine and coarse aggregates shall be made as frequently as possible the frequency for a given job being determined by the engineer-in-charge according to weather conditions. The amount of the added water shall be adjusted to compensate for any observed variations in the moisture content. For the determination of moisture content in the aggregates IS 2386 (Part 3) may be referred to. To allow for the variation in mass of aggregate due to variation in their moisture content, suitable adjustments in the masses of aggregates shall also be made. In the absence of exact data only in the case of nominal mixes the amount of surface water may be estimated from the values given in table below.

**Surface water carried by aggregate**

Sr. No	Aggregate	Approximate quantity of surface water	
		Percent by mass	l/m <sup>3</sup>
(1)	(2)	(3)	(4)
i)	Very wet sand	7.5	120
ii)	Moderately wet sand	5.0	80
iii)	Moist sand	2.5	40
iv)	Moist gravel or crushed rock	1.25 –2.5	20 – 40
	Coarser aggregate less the water it will carry		

No substitutions in materials used on the work or alterations in the established propositions except as permitted as above shall be made without additional tests to show that the quality and strength of concrete are satisfactory.

**MIXING:**

Concrete shall be mixed in a mechanical mixer. The mixer should with IS 1791 and IS 12119. The mixers shall be fitted with water measuring (metering) devices. The mixing shall be continued until there is a uniform distribution of the materials and the mass is uniform in colour and consistency. If there is segregation after unloading from the mixer, the concrete should be remixed.

For guidance, the mixing time shall be at least 2 min. For other types of more efficient mixers, manufacturer’s recommendations shall be followed; for hydrophobic cement it may be decided by the Engineer-in-Charge.

Workability should be checked at frequent intervals.

Dosage of retards, plasticizers and Super plasticizers shall be restricted to 0.50, 1.0 and 2.0 % respectively by weight of cementitious materials and unless higher value is agreed upon between the manufacturer and constructor based on performance test.

Each time the work stops, the mixer shall be cleaned out and when next commencing the mixing, the first batch shall have 10% additional cement to allow for sticking in the drum.

**6.5 SAMPLING AND TESTING CONCRETE IN THE FIELD:** Facilities required for sampling materials and concrete in the field, if Engineer-in-Charge so desires, shall be provided by contractor at no extra cost. The following equipment with operator shall be made available at Engineers request (all must be in serviceable condition):

1.	Cast iron cube moulds 15 cm. Size	12 Nos.(min.)
2.	Slump cone complete with tamping rod	1 Set
3.	Lab. balance to weigh upto 5 kg. with sensitivity of 10 gm.	1 No.
4.	Laboratory balance of 2 kg. capacity and of sensitivity of 1 gm.	1 No.
5.	I.S. sieves for coarse and fine aggregates.	1 Set
6.	A set of measures from 5 ltrs. to 0.1 ltr.	1 Set
7.	Electric oven with thermostat upto 120 °C.	1 No.
8.	Pycnometer	1 No.
9.	Calibrated glass jar 1 ltr. Capacity	2 Nos.
10	Glass flasks and metal containers	As required
11	Concrete cube testing machine (optional)	1 No.

**6.6. TESTING CHARGES:** Different tests required to be carried out for concrete works including the mix design, cube tested as per the above specifications shall be got done by the contractor at his own cost in one of the approved laboratories. The choice of laboratory shall rest with the Department. All incidental charges / cost shall be borne by the contractor.

**6.7 SAMPLING AND STRENGTH TEST OF CONCRETE:**

Samples from fresh concrete shall be taken as per I.S. 1199 and cubes shall be made, cured and tested at 28 days in accordance with I.S. 516.

In order to get a relatively quicker idea of the quality of concrete, option tests on beams for modulus of rupture at 72 (+/-) 2 hours or at 7 days or compressive strength tests at 7 days may be carried out in addition to 28 days compressive strength tests. For this purpose, the values given in table below may be taken for general guidance in the case of concrete made with ordinary cement. In all cases, the 28 days compressive strength specified shall alone be the criterion for acceptance or rejection of the concrete. If however, from test carried out in particular job over a reasonably long period, it has been established to the satisfaction of the Engineer-in-Charge that a suitable ratio between 28 days compressive strength and modulus of rupture at 72 (+/-) 2 hours or 7 days or compressive strength at 7 days may be accepted, the Engineer-in-Charge may suitably relax the frequency of 28 days compressive strength, provided the expected strength values at the specified early age are consistently met.

**Optional Tests Requirements of Concrete:**

Grade of Concrete	Compressive strength on 15 cm cubes min. at 7 days	Modulus of rupture by beam test min.	
		At 72 (+/-) 2 hours N / mm <sup>2</sup>	At 7 days N / mm <sup>2</sup>
M 10	7.0	1.2	1.7
M 15	10.0	1.5	2.1
M 20	13.5	1.7	2.4

M 25	17.0	1.9	2.7
M 30	20.0	2.1	3.0
M 35	23.5	2.3	3.2
M 40	27.0	2.5	3.4

**6.7.1 Frequency of Sampling:**

**Sampling Procedure:** A random sampling procedure shall be adopted to ensure that each concrete batch shall have a reasonable chance of being tested, i.e. the sampling should be spread over the entire period of concreting and cover all mixing units.

**Frequency:** The minimum frequency of sampling of concrete of each grade shall be in accordance with following:

Quantity of concrete In the work (in cum.)	Number of samples
1-5	1
6-15	2
16-30	3
31-50	4
51 and above	4 plus one additional for each additional 50 cum. or part there of

At least one sample shall be taken from each shift. Where concrete is continuous production unit, such as ready - mixed concrete plant, frequency of sampling may be agreed upon mutually by supprunningliers and purchasers.

**6.7.2 Test Specimen:** Three test specimen shall be made from each sample for testing at 28 days. Additional cubes may be required for various purposes such as to determine the strength of concrete at 7days or at the time of striking the form work or to determine the duration of curing or to check the testing error. Additional cubes may also be required for testing cubes cured by accelerated methods as described in I.S. 9013 - 1978. The specimen shall be tested as described in I.S. 516 - 1959.

**6.7.3 Test Strength of Samples:** The test strength of the samples shall be the average of the strength of three specimen. The individual variation should not be more than (+/-) 15 percent of the average.

**6.7.4 Consistency:** Slump test shall be carried out as often as demanded by the Engineer-in-Charge and invariably from the same batch of concrete from which the test cubes are made. Slump tests shall be done immediately after sampling.

**6.7.5 Standard Deviation:** Vide clause 6.4.2 of this specification.

**6.8 ACCEPTANCE CRITERIA:**

The concrete shall be deemed to comply with the strength requirements when both the following conditions are met:

- a) The mean strength determined from any group of four consecutive test results complies with the appropriate limits in column 2 of Table below
- b) Any individual test result complies with the appropriate limits in column of Table below.

**Characteristic Compressive Strength Compliance Requirement:**

Specified grade	Mean of the Group of 4 Non-overlapping consecutive test results in N / mm <sup>2</sup>	Individual test results in N/ mm <sup>2</sup>
(1)	(2)	(3)
M 15	$= / > f_{ck} + 0.825 \times$ established standard deviation (rounded off to nearest 0.5 N/mm <sup>2</sup> ) or $= / > f_{ck} + 3 \text{ N / mm}^2$ whichever is greater	$= / > f_{ck} - 3 \text{ N/ mm}^2$
M 20 Or Above	$= / > f_{ck} + 0.825 \times$ established standard deviation (rounded off to nearest 0.5 N/ mm <sup>2</sup> ) or $= / > f_{ck} + 4 \text{ N / mm}^2$ , whichever is greater	$= / > f_{ck} - 4 \text{ N / mm}^2$

**Note:** In the absence of established value of standard deviation, the values given in (assumed standard deviation) may be assumed, and attempt should be made to obtain results of 30 samples as early as possible to establish the value of standard deviation.

**Flexural Strength**

When both the following conditions are met, the concrete complies with the specified flexural strength.

- (a) The mean strength determined from any group of four consecutive test results exceeds the specified characteristic strength by at least 0.3 N/mm<sup>2</sup>
- (b) The strength determined from any test result is not less than the specified characteristic strength less 0.3N/mm<sup>2</sup>

**Quantity of Concrete Represented by Strength Test Results.**

The quantity of concrete represented by a group of four consecutive test results shall include the batches from which the first and last samples were taken together with all intervening batches.

For the individual test result requirements given in column 2 of above table or in item (b) of flexural strength, only the particular batch from which the sample was taken shall be at risk.

Where the mean rate of sampling is not specified the maximum quantity of concrete that four

consecutive test results represent shall be limited to 60m<sup>3</sup>

If the concrete is deemed not to comply pursuant to above the structural adequacy of the parts affected shall be investigated and any consequential action as needed shall be taken.

Concrete of each grade shall be assessed separately

Concrete is liable to be rejected if it is porous or honey-combed, its placing has been interrupted without providing a proper construction joint, the reinforcement has been displaced beyond the tolerances specified, or construction tolerances have not been met. However, the hardened concrete may be accepted after carrying out suitable remedial measures to the satisfaction of the Engineer-in-Charge.

#### **6.9 ADMIXTURES:**

Admixtures, if used shall comply with IS 9103. Previous experience with and data on such materials should be considered in relation to the likely standards of supervision & workmanship to the work being specified. Admixtures should not impair durability of the concrete not combined with the constituent to form harmful compounds nor increase the risk of corrosion of reinforcement.

The workability, compressive strength and the slump loss of concrete with & without the use of admixtures shall be established during the trial mixes before use of admixtures.

The relative density of liquid admixtures shall be checked for such drum containing admixtures and compared with the specified value before acceptance.

The chloride content of the admixtures shall be independently tested for each batch before acceptance. If two or more admixtures are used simultaneously in the same concrete mix data should be obtained to assess their interaction and to ensure their compatibility.

#### **General:**

Admixture may be used in concrete only with the approval of Engineer-in-charge based upon evidence that, with the passage of time neither the compressive strength nor its durability reduced. When admixtures are used, the designed concrete mix shall be corrected accordingly. Admixtures shall be used as per manufacturers instructions and in the manner and with the control specified by Engineer-in-Charge.

**i) Calcium Chloride:** Calcium chloride shall not be used for accelerating set of the cement for any concrete containing reinforcement or embedded steel parts. When calcium chloride is permitted to be used, such as in mass concrete works, it shall be dissolved in water and added to the mixing water in an amount not to exceed 1.5 percent of the weight of cement in each batch of concrete.

**ii) Air Entraining Agent:** Where specified and approved by Engineer-in-charge, neutralized vinsol resin or any other approved air entraining agent may be used to produce the specified amount of air in the concrete mix and these agents shall conform to the requirements of ASTM standard 6.260, Air Entraining admixtures for concrete. The recommended total air content of the concrete is 4% (+/-) 1%. The method of measuring air content shall be as per I.S.1199.

**iii) Retarding Admixtures:** Where specified and approved by Engineer-in-Charge, retarding agents shall be added to the concrete mix in quantities specified by Engineer-in-Charge.

**iv) Water Reducing Admixtures:** Where specified and approved by Engineer-in-Charge, water reducing lignosulfonate mixture shall be added in quantities specified by Engineer-in-Charge. The admixtures shall be added in the form of a solution.

**v) Water Proofing Agents:** Where specified and approved by Engineer-in-Charge, chloride and sulphate free water proofing agents shall be added in quantities specified by Engineer-in-Charge.

**vi) Other Admixtures:** Engineer-in-Charge may at his discretion, instruct contractor to use any other admixture in the concrete.

## **6.10 INSPECTION OF STRUCTURES:**

Immediately after stripping the form work, all concrete shall be carefully inspected and any defective work or small defects, either removed or made good before concrete has thoroughly hardened, as instructed by Engineer-in-Charge.

In case of doubt regarding the grade of concrete used or results of cube strength are observed to be lower than the designed strength as per specifications at 28 days, compressive strength test of concrete based on core test, ultrasonic test and/or load test shall be carried out by the digital ultrasonic concrete tester by an approved agency as directed by the Engineer-in-Charge all at the cost of the contractor. In case these tests do not satisfy the requirements, the Department will be at liberty to reject the concrete, and the contractor, at his own cost, has to dismantle and re-do the same or carry out such remedial measures as approved by the Department.

## **6.11 TESTING OF STRUCTURES:**

**6.11.1 Optional Tests:** Engineer-in-charge, if he so desires, may order for tests to be carried out on cement, sand, coarse aggregate, water etc. in accordance with the relevant Indian Standards.

**Tests on cement** will be carried out by Department and shall include (i) fineness test, (ii) test for normal consistency, (iii) test for setting time, (iv) test for soundness, (v) test for compressive strength, (vi) test for heat of hydration (by experiment and by calculations) in accordance with I.S.269.

**Tests on sand** shall include (i) sieve test, (ii) test for organic impurities, (iii) decantation test for determining clay and silt content, (iv) specific gravity test, (v) test for unit weight and bulkage factor, (vi) test for sieve analysis and fineness modulus.

**Tests on coarse aggregate** shall include (i) sieve analysis, (ii) specific gravity and unit weight of dry, loose and rodded aggregate, (iii) soundness and alkali aggregate reactivity, (iv) spectrographic examination, (v) deleterious materials and organic impurities, (vi) test for aggregate crushing value.

The test on aggregates would normally be ordered to be carried out only if Engineer-in-charge feels the materials are not in accordance with the specifications or if the specified concrete strengths are not obtained and shall be performed by contractor at an approved test laboratory. Contractor shall

have to pay all the charges of optional tests. If the work cubes do not give the stipulated strengths, Engineer-in-Charge reserves the right to ask contractor to dismantle such portions of the work, which in his opinion are unacceptable and re-do the work to the standards stipulated at contractors cost.

The unit rate for concrete shall be all inclusive including making preliminary mix design and test cubes, works cubes, testing them as per specifications, slump tests, optional tests etc. Complete. However, the Department will test the cubes departmentally. The contractor will have to make arrangements for transportation to the laboratory and testing charges will be borne by the contractor.

The contractor should also conduct **conclusive tests** such as ultrasonic pulse test, core test etc. to prove the suitability of concrete, in case cube tests give unsatisfactory results. The cost of the conclusive test should be borne by the contractor.

**6.11.2 Core Test:** The points from which cores are to be taken and the number of cores required, shall be at the discretion of the Engineer-in-Charge and shall be representative of the whole of concrete concerned. In no case, however, shall fewer than three cores be tested. Cores shall be prepared and tested as described in I.S. 516

**6.11.3** Concrete in the member represented by a core test shall be considered acceptable if the average equivalent cube strength of the cores is equal to at least 85% of the cube strength of the grade of concrete specified for the corresponding age and no individual core has a strength less than 75%.

In case the core test results do not satisfy the requirements as above or where such tests have not been done, load test (see 6.11.3) may be resorted to.

**6.11.4 Load Tests on Parts of Structure (if the sample cube fails):**

Load tests should be carried out as soon as possible after expiry of 28 days from the time of placing of concrete.

The structure should be subjected to a load equal to full dead load of the structure plus 1.25 times the imposed load for a period of 24 hours and then the imposed load shall be removed.

**Note:** Dead load includes weight of the structural members plus weight of finishes and walls or partitions, if any, as considered in the design.

The deflection due to imposed load only shall be recorded. If within 24 hours of removal of the imposed load, the structure does not recover at least 75% of the deflection under super imposed load, the test may be repeated after a lapse of 72 hours. If the recovery is less than 80%, the structure shall be deemed to be unacceptable.

If the maximum deflection in mm. shown during 24 hours under load is less than  $40L^2/D$ , where L is the effective span in M. and D the overall depth of the section in mm, it is not necessary for recovery to be measured and the recovery provision as above will not apply.



Other non-destructive test methods may be adopted, in which case the acceptance criteria shall be agreed upon between the Engineer-in-Charge and the Contractor and the test shall be done under expert guidance.

#### **MEMBERS OTHER THAN FLEXURAL MEMBERS:**

Members other than flexural members should be preferably investigated by analysis.

#### **Non – destructive tests:**

Non-destructive tests are used to obtain estimation of properties of concrete in the structure. The methods adopted include ultrasonic pulse velocity [see IS 13311 (Part 1)] and rebound hammer [IS 13311 (Part 2)], probe penetration, pull out and maturity. Non-destructive tests provide alternatives to core tests for estimating the strength of concrete in a structure, or can supplement the data obtained from a limited number of cores. These methods are based on measuring a concrete property that bears some relationship to strength/ the accuracy of these methods, in part is determined by the degree of correlation between strength and the physical quality measured by the non-destructive tests.

Any of these methods may be adopted, in which case the acceptance criteria shall be agreed upon prior to testing.

#### **6.11.5 Testing of Underground Water Tank/Septic Tank/Underground Structures:**

The tank will be tested after the completion according to the procedure laid down here:

The middle compartment shall be filled first to its full height and the leakage if any shall be checked on its outer surfaces and if found, the same shall be examined carefully and defects rectified/grouted if necessary. The drop in level of surface of water shall also be recorded for 48 hours. If this drop in level exceeds 20 mm. and shows any leakage in the said walls, necessary steps shall be taken in consultation with the Engineer-in-Charge.

After this compartment is tested to the satisfaction of the Engineer-in-Charge, all water from middle compartment shall be pumped into side compartment to the full height and checked for water leakages from the outer surfaces of the tank as well as inner surface of the middle compartment. The drop in level of surface of water shall also be checked as stated above and defects rectified.

The external surface of the tank shall then be plastered and cured as per the specifications and back filling shall be taken up thereafter. The water from the compartments shall then be pumped out and the inner surface of the tank in all compartments then be checked and defects rectified.

After satisfactory completion of checks, internal plaster shall be taken up as specified in the specifications.

#### **6.11.6 Unsatisfactory Tests:**

Should the results of any test prove unsatisfactory, or the structure shows signs of weakness, undue

deflection or faulty construction, contractor shall remove and rebuild the member or members involved or carry out such other remedial measures as may be required by Engineer-in-Charge. Contractor shall bear the cost of so doing, unless the failure of the member or members to fulfill the test conditions is proved to be solely due to faulty design. The cost of load and other tests shall be borne by Contractor if the tests show unsatisfactory results; otherwise such costs will be borne by the Department.

#### **6.12 CONCRETE IN ALKALI SOILS WATER & AGGREGATES:**

Some aggregates containing particular varieties of silica may be susceptible to attack by alkalis ( $\text{Na}_2\text{O}$  and  $\text{K}_2\text{O}$ ) originating from cement and other sources, producing an expansive reaction which can cause cracking and disruption of concrete. Damage to concrete from this reaction will normally only occur when all the following are present together.

- a) A high moisture level, within the concrete;
- b) A cement with high alkali content, or another source of alkali;
- c) Aggregate containing an alkali reactive constituent.

Where the service records of particular cement / aggregate combination are well established, and do not include any instances of cracking due to alkali-aggregate reaction, no further precautions should be necessary. When the materials are unfamiliar, precautions should take one or more of the following forms:

- a) Use of non-reactive aggregate from alternate sources
- b) Use of low alkali ordinary Portland cement having total alkali content not more than 0.6 percent (as  $\text{Na}_2\text{O}$  equivalent).

Further advantage can be obtained by use of fly ash (Grade I) conforming to IS 3812 or granulated blast furnace slag conforming to IS 12089 as part replacement of ordinary Portland cement (having total alkali content as  $\text{Na}_2\text{O}$  equivalent not more than 0.6 percent) provided fly ash content is at least 20 % or slag content is at least 50 percent.

- c) Measures to reduce the degree of saturation of the concrete during service such as use of impermeable membranes
- d) Limiting the cement content in the concrete mix and thereby limiting total alkali content in the concrete mix as per approval of Engineer- in-charge.

#### **Chlorides in the concrete**

Whenever there is chlorides in concrete there is an increased risk of corrosion of embedded metal. The higher the chloride content or if subsequently exposed to warm moist conditions, the greater the risk of corrosion. All constituents may contain chlorides and concrete may be contaminated by chlorides from the external environment. To minimize the chance of deterioration of concrete from harmful chemical salts, the levels of such harmful salts in concrete materials, that is, cement, aggregates, water and admixtures, as well as by diffusion from the environment should be limited. The total amount of chloride content (as Cl) in the concrete at the time of placing shall be as given below in the table.

### Limits of Chloride Content of Concrete

Sl.No	Type or Use of Concrete	Maximum Total Acid soluble Chloride Content Expressed as kg/m <sup>3</sup> of Concrete.
(1)	(2)	(3)
i)	Concrete containing metal and steam cured at elevated temperature and pre-stressed concrete	0.4
ii)	Reinforced concrete or plain concrete containing embedded metal	0.6
iii)	Concrete not containing embedded metal or any material requiring protection from chloride	3.0

The total acid soluble chloride content should be calculated from the mix proportions and the major chloride contents of each of the constituents. Whenever possible the total chloride content of the concrete should be determined as per the approval of the Engineer-in-Charge.

#### Sulphates in concrete:

Sulphates are present in most cements and in some aggregates; excessive amounts of water-soluble sulphate from these or other mix constituents can cause expansion and disruption of concrete. To prevent this, the total water-soluble sulphate content of the concrete mix, expressed as SO<sub>3</sub>, should not exceed 4 per cent by mass of the cement in the mix. The sulphate content should be calculated as the total from the various constituents of the mix as per the approval of the Engineer-in-Charge.

The 4 percent limit does not applied to concrete made with super sulphated cement complying with IS 6909 or as approved by the Engineer-in-Charge.

### 6.13 PREPARATION PRIOR TO CONCRETE PLACEMENT, FINAL INSPECTION & APPROVAL:

Before the concrete is actually placed in position, the inside of the form work shall be inspected to see that they have been cleaned and oiled. Temporary openings shall be provided to facilitate inspection, especially at bottom of columns and wall forms, to permit removal of saw dust, wood shavings, binding wire, rubbish, dirt etc. Opening shall be placed or holes drilled so that these materials and water can be removed easily. Such openings / holes shall be later suitably plugged.

The various traders shall be permitted ample time to install drainage and plumbing lines, floor and trench drain, conduits, hangers, anchors, inserts, sleeves, bolts, frames and other miscellaneous embedments to be cast in the concrete as indicated on the drawing or as necessary for the proper execution of the work. All such embedments shall be correctly positioned and securely held in the forms to prevent displacement during depositing and vibrating of concrete.

Slots, openings, holes, pockets etc. shall be provided in the concrete work in the positions indicated in the drawings or as directed by the Engineer-in-Charge.

Reinforcement and other items to be cast in concrete shall have clean surfaces that will not impair bond.

Prior to concrete placement, all works shall be inspected and approved by Engineer-in-Charge, and if found unsatisfactory, concrete shall not be poured until all defects have been corrected at contractors cost.

Approval by Engineer-in-Charge of any and all materials and work as required herein shall not relieve contractor from his obligations to produce finished concrete in accordance with the drawings and specifications.

#### **6.13.1 Rain or Wash Water:**

No concrete shall be placed in wet weather or on a water covered surface. Any concrete that has been washed by heavy rain shall be entirely removed, if there is any sign of cement and sand having been washed away from the concrete mixture. To guard against damage which may be caused by rain, the works shall be covered with tarpaulins immediately after the concrete has been placed and compacted before leaving the work unattended. Any water accumulating on the surface of the newly placed concrete shall be removed by approved means and no further concrete shall be placed thereon until such water is removed. To avoid flow of water over/around freshly placed concrete, suitable drains and sumps shall be provided.

#### **6.13.2 Bonding Mortar:**

Immediately before concrete placement begins, prepared surfaces, except form work, which will come in contact with concrete to be placed, shall be covered with a bonding mortar of same strength of concrete.

#### **6.13.3 Transportation:**

All buckets, containers or conveyers used for transporting concrete shall be mortar-tight. All means of conveyance shall be adopted to deliver concrete of the required consistency and plasticity without segregation or loss of slump whatever method of transportation is employed. Chute shall not be used to transport the concrete without the written permission of the Engineer-in-Charge and concrete shall not be rehandled before placing.

#### **6.13.4 Retempered or Contaminated Concrete:**

Concrete must be placed in its final position before it becomes too stiff to work. On no account water shall be added after the initial mixing. Concrete which has become stiff or has been contaminated with foreign materials and which has not been placed within half an hour of mixing water with cement shall be rejected.

#### **6.13.5 Cleaning of Equipment:**

All equipments used for mixing, transporting and placing of concrete shall be maintained in clean

condition. All pans, buckets, hoppers, chutes, pipe lines and other equipments shall be thoroughly cleaned after each period of placement.

#### **6.13.6 Procedure for Placing of Concrete:**

**a) Engineers Approval of Equipment and Methods:** Before any concrete is placed, the entire placing programme, consisting of equipment, layout proposed procedures and methods shall be submitted to Engineer-in-Charge and no concrete shall be of such size and design to ensure a practically continuous flow of concrete during depositing without segregation of materials, considering the size of the job and placement location.

**b) Time Interval between Mixing and Placing:** Concrete shall be placed in its final position before the cement reaches its initial set and concrete shall normally be compacted in its final position within thirty minutes of leaving the mixer and once compacted it shall not be disturbed.

**c) Avoiding Segregation:** Concrete shall in all the cases be deposited as nearly as practicable directly in its final position and shall not be rehandled or caused to flow in a manner which will cause segregation, loss of materials, displacement of reinforcement, shuttering or embedded inserts or impair its strength. For locations where direct placement is not possible, and in narrow forms, contractor shall provide suitable prop and Elephant Trunks to confine the movement of concrete. Special care shall be taken when concrete is dropped from a height, especially if reinforcement is in the way, particularly in columns and thin walls.

**d) Placing by Manual Labour:** Except when otherwise approved by Engineer-in-Charge, concrete shall be placed in the shuttering by shovels or other approved implements and shall not be dropped from a height more than 1.0 m. or handle in a manner which will cause segregation.

**e) Placing by Mechanical Equipment:** The following specifications shall apply when placing of concrete by use of mechanical equipment is specially called for while inviting bids or is warranted, considering the nature of work involved.

The control of placing shall begin at the mixer discharge. Concrete shall be discharged by a vertical drop into the middle of the bucket of hopper and this principle of a vertical discharge of concrete shall be adhered-to through-out all stages of delivery until the concrete comes to rest in its final position.

**Type of buckets:** All concrete shall be conveyed from the mixer to the place of final deposit in suitable buckets, dumpers, containers which shall be leak-tight. All means of conveyance shall be adopted for delivering concrete to the required consistency/ workability and plasticity without segregation.

Central bottom dump buckets of a type that provides for positive regulation of the amount and rate deposition of concrete in all dumping position shall be employed.

**Operation of Bucket:** In placing concrete in large open areas, the bucket shall be spotted directly over the position designated and then lowered for dumping. The open bucket shall clear the concrete already in place and the height of drop shall not exceed 1.0 m. The bucket shall be opened slowly to

avoid high vertical bounce. Dumping of buckets on the swing or in any manner which results in separation of ingredients or disturbance of previously placed concrete will not be permitted.

**f) Placement in Restricted Forms:** Concrete placed in restricted forms by borrows, buggies, cars, short chutes or hand shoveling shall be subject to the requirement for vertical delivery of limited height to avoid segregation and shall be deposited as nearly as practicable in its final position.

**g) Chuting:** Where it is necessary to use transfer chutes, specific approval of Engineer-in-Charge must be obtained to type, length, slopes, baffles, vertical terminal and timing of operations. These shall be so arranged that almost continuous flow of concrete is obtained at the discharge and without segregation. To allow for the loss of mortar against the sides of the chutes, the first mixes shall have less coarse aggregate. During cleaning of chutes, the waste water shall be kept clear of the forms. The concrete shall not be permitted to fall from the end of the chutes by more than 1.0 m. Chutes, when approved for use, shall have slopes not flatter than 1 vertical to 3 horizontal and not steeper than 1 vertical to 2 horizontal, chutes shall be of metal or metal line and of rounded cross section. The slopes of all chute sections shall be approximately same. The discharge end of the chutes shall be maintained above the surfaces of the concrete in the forms.

**h) Placing by Pumping/ Pneumatic Placers:** Concrete may be conveyed and placed by mechanically operated equipment e.g. pumps or pneumatic placers, only with the written permission of Engineer-in-Charge. The slump shall be held to the minimum, necessary for conveying concrete by this method.

When pumping is adopted, before pumping of concrete is started, the pipelines shall be lubricated with one or two batches of mortar composed of one part cement and two parts sand. The concrete mix shall specially designed to suit pumping. Care shall be taken to avoid stoppages in work once pumping has started.

When pneumatic placer is used, the manufacturer's advice on layout of pipeline shall be followed to avoid blockages and excessive wear. Restraint shall be provided at the discharge box to cater for the reaction at the end.

Manufacturer's advice shall be followed regarding concrete quality and all other related matters when pumping/ pneumatic placing equipments are used.

**h) Concrete in Layers:** Concreting, once started, shall be continuous until the pour is completed. Concrete shall be placed in successive horizontal layers of uniform thickness ranging from 15 cm. to 90 cm. as directed by Engineer-in-Charge. These shall be placed as rapidly as practicable to prevent the formation of cold joints or planes of weakness between each succeeding layers within the pour. The thickness of each layer shall be such that it can be deposited before the previous layer has stiffened. The bucket loads or other units of deposit, shall spotted progressively along the face of the layer with such overlap as will facilitate spreading the layer to uniform depth and texture with a minimum of shoveling stones into mortar rather than mortar on to stones. Such a condition shall be corrected by redesign of mix or other means, as directed by Engineer-in-Charge.

**Bedding of Layers:** The top surface of each pour and bedding planes shall be approximately horizontal unless otherwise instructed.

**COMPACTION:**

**6.13.7 COMPACTION:** Concrete shall be compacted during placing, with approved vibrating equipment, until the concrete has been consolidated to the maximum practicable density, is free of pockets of coarse aggregate and fits tightly against all form surfaces, reinforcement and embedded fixtures. Particular care shall be taken to ensure that all concrete placed against the form faces and into corners of forms or against hardened concrete at joints is free from voids or cavities. The use of vibrators shall be consistent with the concrete mix and caution is to be exercised not to over vibrate the concrete to the point of segregation.

**a) Type of Vibrators:** Vibrators shall conform to I.S. specifications. Type of vibrators to be used shall depend upon the structure where concrete is to be placed. Shutter vibrators, to be effective, shall be firmly secured to the form work which must be sufficiently rigid to transmit the vibrations and strong enough not to be damaged by it. Immersion vibrators shall have No load frequency amplitude and acceleration as per I.S.2505 depending on the size of the vibrator. Immersion vibrators in sufficient numbers and each of adequate size shall be used to properly consolidate all concrete. Tapping or external vibrating of forms by hand tools or immersion vibrators will not be permitted.

**b) Use of Vibrators:** The exact manner application and the most suitable machines for the purpose must be carefully considered and operated by experienced men. Immersion vibrators shall be inserted vertically at points not more than 450 mm. apart and withdrawn when air bubbles cease to come to the surface. Immersion vibrators shall be withdrawn very slowly. In no case shall immersion vibrators be used to transport concrete inside the forms. Particular attention shall be paid to vibration at the top of lift, e.g. in a column or wall.

**c) Melding successive batches:** When placing concrete in layers, which are advancing horizontally as the work progress, great care shall be exercised to ensure adequate vibration, blending and melding of the concrete between the successive layers.

**d) Penetration of vibrators:** The immersion vibrator shall penetrate the layer being placed and also penetrate the layer below while the under layer is still plastic to ensure good bond and homogeneity between the two layers and prevent the formation of cold joints.

**e) Vibrating against reinforcement:** Care shall be taken to prevent contact of immersion vibrators against reinforcement steel. Immersion vibrators shall not be allowed to come in contact with reinforcement steel after start of initial set. They shall also not be allowed to come in contact with forms or finished surfaces.

**f) Use of Form Attached Vibrators:** Form attached vibrators shall be used only with specific authorization of Engineer-in-Charge.

**g) Use of surface vibrators:** The use of surface vibrators will not be permitted under normal conditions. However, for thin slabs, such as highways, runways and similar construction, surface

vibrations by specifically designed vibrators may be permitted, upon approval of Engineer-in-Charge.

**6.13.8 STONE POCKETS AND MORTAR PONDAGES:** Formation of stone pockets or mortar pondages in corners and against faces of forms shall not be permitted. Should these occur, they shall be dug out, reformed and refilled to a sufficient depth and shape for thorough bounding as directed by Engineer-in-Charge.

**6.13.9 PLACEMENT INTERVAL:** Except when placing with slip forms, each placement of concrete in multiple lift work, shall be allowed to set for at least 24 hours after the final set of concrete and before the start of a subsequent placement.

**a) Special Provision in Placing:** When placing concrete in walls with openings, in floors of integral slab and beam construction and other similar conditions, the placing shall stop when the concrete reaches the top of the opening in walls or bottom horizontal surface of the slabs as the case may be. Placing shall be resumed before the concrete in place takes initial set, but not until it has had time to settle as determined by Engineer-in-charge.

**b) Placing Concrete Through Reinforcing Steel:** While placing concrete through reinforcing steel, care shall be taken to prevent segregation of the coarse aggregate. Where the congregation of steel make placing difficult, it may be necessary to temporarily move the top steel aside to get proper placement and restore reinforcing steel to design position.

**6.13.10 BLEEDING:** Bleeding or free water on top of concrete being deposited in to the forms, shall be caused to stop the concrete pour and the conditions causing this defect corrected before any further concreting is resumed.

#### **6.14 CONSTRUCTION JOINTS AND KEYS:**

Concrete shall be placed without interruption until completion of the part of the work between predetermined construction joints, as specified therein after. Time lapse between the pouring of adjoining units shall be as specified in the drawings or as directed by Engineer-in-Charge.

##### **Construction joints and cold joints:**

Joints are a common source of weakness and therefore it is desirable to avoid them. If this is not possible, their number shall be minimized. Concreting shall be carried out continuously up to construction joints the position and arrangement of which shall be indicated by the designer. Construction joints should comply with IS 11817.

Construction joints shall be placed at accessible locations to permit cleaning out of laitance, cement slurry and unsound concrete, in order to create rough/uneven surface It is recommended to clean out laitance and cement slurry by using wire brush on the surface of joint immediately after initial setting of concrete and to clean at the same immediately thereafter. The prepared surface should be in a clean saturated surface dry condition when fresh concrete is placed, against it. In the case of construction joints at locations where the previous pour has been cast against shuttering the recommended method of obtaining a rough surface for the previously poured concrete is to expose the aggregate with a high pressure water jet or any other appropriate means.



Fresh concrete should be thoroughly vibrated near construction joints so that mortar from the new concrete flows between large aggregates and develop proper bond with old concrete.

Where high shear resistance is required at the construction joints, shear keys may be provided.

Sprayed curing membranes and release agent should be thoroughly removed from joint surfaces.

If stopping of concreting becomes unavoidable anywhere, a properly formed construction joint shall be made where the work is stopped. Joints shall be either vertical or horizontal, unless shown otherwise in drawing. In case of an inclined or curved member, the joints shall be at right angles to the axis of the member. Vertical joints in walls shall be kept to a minimum. Vertical joints shall be formed against a stop board, horizontal joints shall be level and wherever possible, arranged, so that the joint lines coincide with the architectural features of the finished work. Battens, shall be nailed to the form work to ensure a horizontal line and if directed, shall also be used to form a grooved joint. For tank walls, similar work joints shall be formed as per I.S. 3370. Concrete that is in the process of setting shall not be disturbed or shaken by traffic either on the concrete itself or upon the shuttering. Horizontal and vertical construction joints and shear keys shall be located and shall conform in detail to the requirements of the plans unless otherwise directed by Engineer-in-Charge. Where not described, the joints shall be in accordance with the following:

**a) Column Joints:** In a column, the joint shall be formed 75 mm. below the lowest soffit of the beams including haunches if any. In flat slab construction the joint shall be 75 mm. below the soffit of column capital. At least 2 hours shall elapse after depositing concrete in column, piers or walls, before depositing in beams, girders or slabs supported thereon.

**b) Beam and Slab Joints:** Concrete in a beam shall be placed throughout without a joint but if the provision of a joint is unavoidable, the joint shall be vertical and at the Centre or within the middle third of the span unless otherwise shown in drawing. Where a beam intersects a girder, the joints in the girder shall be offset a distance equal to twice the width of the beam and additional reinforcement provided for shear. The joints shall be vertical throughout the full thickness of the concrete member. A joint in a slab shall be vertical and parallel to the principal reinforcement. Where it is unavoidable at right angles to the principle reinforcement, the joint shall be vertical and at the middle of span.

**c) Joints in Liquid Retaining Structures:** Vertical construction joints in watertight construction will not be permitted unless indicated on the drawings. Where a horizontal construction joint is required to resist water pressure, special care shall be taken in all phases of its construction to ensure maximum water tightness.

**d) Dowels:** Dowels for concrete work, not likely to be taken up in the near future, shall be wrapped in tar paper and burlap.

**e) Mass Foundations:** Mass foundations shall be poured in lifts not exceeding 1.5 m. in height unless, otherwise indicated on the drawings and approved by Engineer-in-Charge.

**f) Treatment of Construction Joints on Resuming Concreting:** Drier shall be used for the top lift or horizontal pours to avoid a laitance. All laitance and loose stones shall be thoroughly and carefully

removed by wire brushing/ hacking and surface washed.

Just before concreting is resumed, the roughened joint surface shall be thoroughly cleaned and loose matter removed and then treated with a thin layer of cement grout of proportion specified by Engineer-in-Charge and worked well into the surface. The new concrete shall be well worked specially against the prepared face before the grout mortar sets. Special care shall be taken to obtain thorough compaction and to avoid segregation of the concrete along the joint plane.

#### **6.15 CURING, PROTECTING, REPAIRING, AND FINISHING:**

**a) Curing:** All concrete shall be cured by keeping it continuously damp for the period of time required for complete hydration and hardening to take place. Preference shall be given to the use of continuous sprays or ponded water, continuously saturated covering of sacking, canvas, hessian or other absorbent materials, or approved effective curing compounds applied with spraying equipment capable of producing a smooth, even textured coat. Extra precautions shall be exercised in curing concrete during cold and hot weather as outlined hereinafter. The quality of curing water shall be the same as that used for mixing concrete.

Certain types of finish or preparation for overlaying concrete must be done at certain stages of curing process and special treatment may be required for specific concrete surface finish.

Curing of concrete made of high alumina cement and super sulphated cement shall be carried out as directed by Engineer-in-Charge.

**b) Curing with Water:** Fresh concrete shall be kept continuously wet for a minimum period of 14 days from the date of placing of concrete, following a lapse of 12 to 24 hours after laying concrete. The curing of horizontal surfaces exposed to the drying winds shall however begin immediately the concrete has hardened. Water shall be applied to unformed concrete surfaces within 1 hour after concrete has set. Water shall be applied to formed surfaces immediately upon removal of forms. Quantity of water applied shall be controlled so as to prevent erosion of freshly placed concrete.

**c) Continuous Spraying:** Curing shall be assured by use of an ample water supply under pressure in pipes, with all necessary appliances of hose sprinklers and spraying devices. Continuous fine mist spraying or sprinkling shall be used, unless otherwise specified or approved by Engineer-in-Charge.

**d) Alternate Curing Methods:** Whenever in the judgment of Engineer-in-Charge, it may be necessary to omit the continuous spray method, covering of clean sand or other approved means such as wet gunny bags, which will prevent loss of moisture from the concrete, may be used. Any type of covering which would stain or damage the concrete during or after the curing period, will not be permitted. Covering shall be kept continuously wet during the curing period.

For curing of concrete in pavements, side-walks, floors, flat roofs or other level surfaces, the ponding method of curing is preferred. The method of containing the ponded water shall be approved by Engineer-in-Charge. Special attention shall be given to edges and corners of the slab to ensure proper protection to these areas. The ponded areas shall be kept continuously filled with water during the curing period.

**e) Curing Compounds:** Surface coating type curing compound shall be used only on special permission of Engineer-in-Charge. Curing compounds shall be liquid type while pigmented, conforming to U.S. Bureau of Reclamation Specification. No curing compound shall be used on surface where future blending with concrete, water or acid proof membrane or painting is specified.

**f) Curing Equipment:** All equipments and materials required for curing shall be on hand and ready for use before concrete is placed.

**g) Moist Curing:** Exposed surfaces of concrete shall be kept continuously in a damp or wet condition by ponding or by covering with a layer of sacking, canvas, hassian or similar materials and kept constantly wet for at least seven days from the date of placing concrete. In case of ordinary Portland cement and at least ten days where mineral admixtures or blended cement are used. The period of curing shall not be less than ten days of concrete exposed to dry and hot weather conditions. In the case of concrete the mineral admixtures or blended cement are used, it is recommended that the above minimum periods may be extended to fourteen days as per the approval of the Engineer-in-Charge.

**h) Membrane Curing:** Approved curing compounds may be used in lieu of moist curing with the permission of Engineer-in-charge. Such compounds shall be applied to all exposed surfaces of the concrete as soon as possible after the concrete has set. Impermeable membranes such as poly ethylene sheeting covering, closely the concrete surface may also be used to provide effective barrier against evaporation.

For the concrete containing Portland pozzolona cement, Portland slag cement or mineral admixtures increased period of curing may be decided by Engineer-in-charge.

The rate of strength development at early age of concrete made with super sulphated cement is significantly reduced at lower temperatures. Super sulphated cement concrete is seriously affected by inadequate curing and the surface has to be kept moist for at least seven days or more as per the approval of the Engineer-in-Charge.

#### **6.16 PROTECTING FRESH CONCRETE:**

Fresh concrete shall be protected from the elements, from defacements and damage due to construction operations by leaving forms in place for ample period as specified later in this specification. Newly placed concrete shall be protected by approved means such as tarpaulins from rain, sun and winds. Steps as approved by Engineer-in-Charge, shall also be taken to protect immature concrete from damage by debris, excessive loading, vibrations, abrasion or contact with other materials etc. that may be warned against and prevented from disturbing green concrete during its setting period. If it is necessary that workmen enter the area of freshly placed concrete, Engineer-in-Charge may require that bridges be placed over the area.

#### **6.17 REPAIR AND REPLACEMENT OF UNSATISFACTORY CONCRETE:**

Immediately after the shuttering is removed, the surface of concrete shall be very carefully gone over and all defective areas called to the attention of Engineer-in-Charge who may permit patching of the

defective areas or else reject the concrete unit either partially or entirely. Rejected concrete shall be removed and replaced by Contractor at no additional expense to the Department. Holes left by form bolts etc. shall be filled up and made good with mortar composed of one part of cement to one and half parts of sand passing through 2.36 mm. I.S. sieve after removing any loose stones adhering to the concrete. Mortar filling shall be struck off flush at the face of the concrete. Concrete surface shall be finished as described under the particular item of work.

Superficial honey combed surfaces and rough patches shall be similarly made good immediately after removal of shuttering, in the presence of Engineer-in-Charge and superficial water and air holes shall be filled in. The mortar shall be well worked into the surface with wooden float. Excess water shall be avoided. Unless instructed otherwise by Engineer-in-Charge, the surface of the exposed concrete placed against shuttering shall be rubbed down immediately on removal of shuttering to remove fine or other irregularities, care being taken to avoid damaging the surfaces. Surface irregularities shall be removed by grinding.

If reinforcement is exposed or the honey combing occurs at vulnerable position e.g. ends of beams or columns, it may be necessary to cut out the member completely or in part and reconstruct. The decision of Engineer-in-Charge shall be final in this regard. If only patching is necessary, the defective concrete shall be cut out till solid concrete is reached (or to a minimum depth of 25 mm.), the edges being cut perpendicular to the affected surface or with a small under cut if possible, anchors, tees or dowels shall be provided in slots whenever necessary to attach the new concrete securely in place. An area extending several centimetres beyond the edges and the surfaces of the prepared voids shall be saturated with water for 24 hours immediately before the patching material is placed.

**a) Use of Epoxy:** The use of epoxy for bonding fresh concrete used for repairs will be permitted upon written approval of Engineer-in-Charge. Epoxies shall be applied in strict accordance with the instruction of the manufacturer.

**b) Method of Repair:** Small size holes having surface dimensions about equal to the depth of the hole, holes left after removal of form bolts, grout insert holes and slots cut for repair of cracks shall be repaired as follows:

The hole to be patched shall be roughened and thoroughly soaked with clean water until absorption stops.

A 5 mm. thick layer of grout of equal parts of cement and sand shall be well brushed into the surface to be patched followed immediately by the patching concrete which shall be well consolidated with a wooden float and left slightly proud of the surrounding surface. The concrete patch shall be built up in 10 mm. thick layers. After an hour or more, depending upon weather conditions, it shall be worked off flush with a wooden float and a smooth finish obtained by wiping with hessian. Steel trowel shall not be used for this purpose. The mix for patching shall be of the same materials and in the same proportions as that used in the concrete being repaired, although some reduction in the maximum size of the coarse aggregates may be necessary and the mix shall be kept as dry as possible.

Mortar filling by air pressure (guniting) shall be used for repair of areas to large and/ or too shallow

for patching with mortar. Patched surfaces shall be given a final treatment to match the colour and texture of the surrounding concrete. White cement shall be substituted for ordinary cement, if so directed by Engineering-in-Charge, to match the shade of the patch with the original concrete.

**c) Curing of Patched Work:** The patched area shall be covered immediately with an approved non-staining water-saturated material such as gunny bags, which shall be kept continuously wet and protected against sun and wind for a period of 24 hours. Thereafter, the patched area shall be kept wet continuously by a fine spray of sprinkling water for not less than 10 days.

**d) Approval by Engineer-in-Charge:** All materials, procedures and operations used in the repair of concrete and also the finished repair work shall be subject to the approval of Engineer-in-Charge. All fillings shall tightly bonded to the concrete and shall be sound, free from shrinkage cracks after the fillings have been cured and dried.

#### **6.18 FINISHING:**

This specification is intended to cover the treatment of concrete surfaces of all structures.

**a) Finish for Formed Surfaces:** The type of finish for formed concrete surfaces shall be as follows, unless otherwise specified by the Engineer in charge:

For surfaces against which backfill or concrete is to be placed, no treatment is required except repair of defective areas.

For surfaces below grade, which will receive waterproofing treatment, the concrete shall be free of surface irregularities which would interfere with proper application of the water-proofing materials which is specified for use.

Unless specified, surfaces which will be exposed when the structure is in service shall receive no special finish, except repair of damaged or defective concrete, removal of fins and abrupt irregularities, filling of holes left by form ties and rods and cleanup of loose or adhering debris.

Surfaces which will be exposed to the weather and which would normally be levelled, shall be sloped for drainage. Unless the drawing specify a horizontal surface or shows the slope required, the tops of narrow surfaces such as staircase treads, walls, curbs and parapets shall be sloped across the width approx. as 1 in 30. Broader surfaces such as walkways, roads, parking areas and platforms shall be sloped about 1 in 50. Surfaces that will be covered by backfill or concrete, sub floors to be covered with concrete topping, terrazzo or quarry tile and similar surfaces shall be smooth, screeded and leveled to produce even surfaces. Surface irregularities shall not exceed 6mm. Surfaces which will not be covered by backfill, concrete or tile topping such as outside decks, floors of galleries and sumps, parapets, gutters, sidewalks, floors and slabs shall be consolidated, screeded and floated.

Excess water and laitance shall be removed before final finishing. Floating may be done with hand or power tools and started as soon as the screeded surface has attained a stiffness to permit finishing operations and these shall be the minimum required to produce a surface uniform in texture and free from

screed marks or other imperfections. Joints and edges shall be tooled as called for on the drawings or as directed By Engineer-in-Charge.

**b) Standard Finish for Exposed Concrete:** Exposed concrete shall mean any concrete other than floors or slabs exposed to view upon completion of the job. Unless otherwise specified on the drawings, the standard finish for exposed concrete shall be of smooth finish.

A smooth finish shall be obtained with use of lined or plywood forms having smooth and even surfaces and edges. Panels and form linings shall be of uniform size and be as large as practicable and installed with closed joints. Upon removal of forms, the joint marks shall be smoothed off and all blemishes, projections etc. removed, leaving the surfaces reasonably smooth and unmarred.

**c) Integral Cement Concrete Finish:** When specified on the drawings, an integral cement concrete finish of specified thickness for floors and slabs shall be applied either monolithic or bonded, as specified in the drawings and as per I.S.2571. The surface shall be compacted and then floated with a wooden float or power floating machine. The surface shall be tested with a straight edge and any high and low spots eliminated. Floating or trowelling of the finish shall be permitted only after all surface water has evaporated. Dry cement or a mixture of dry cement and sand shall not be sprinkled directly on the surface of the cement finish to absorb moisture or to stiffen the mix.

**d) Rubbed Finish:** A rubbed finish shall be provided only on exposed concrete surfaces as specified on the drawings. Upon removal of forms, all fins and other projections on the surfaces shall be carefully removed, off sets leveled and voids and/ or damaged sections immediately saturated with water and repaired by filling with concrete or mortar of the same composition as was used in the surfaces. The surfaces shall then be thoroughly wetted and rubbed with carborandum or other abrasive. Cement mortar may be used in the rubbing, but the finished surfaces shall not be brush coated with either cement or grout after rubbing. The finished surfaces shall present a uniform and smooth appearance.

#### **6.19 PROTECTION:**

All concrete shall be protected against damage until final acceptance by Engineer-in-Charge.

#### **6.20 FOUNDATION BEDDING, BONDING AND JOINTING:**

All surfaces upon or against which concrete will be placed shall be suitably prepared by thoroughly cleaning, washing and dewatering as may be indicated in the plans or as Engineer-in-Charge may direct to meet the various situations encountered in the work.

Soft or spongy areas shall be cleaned out and back filled with either a soil cement mixture, lean concrete or clean sand fill compacted to minimum density of 90% Modified Proctor, unless otherwise mentioned in schedule of quantities.

Prior to construction of form work for any item where soil will not act as bottom form, approval shall be obtained from Engineer-in-Charge as to the suitability of the soil.

### **6.21 PREPARATION OF ROCK STRATA OF FOUNDATIONS:**

To provide tight bond with rock foundations, the rock surface shall be prepared and the following general requirements shall be observed:

Concrete shall not be deposited on large sloping rock surface. Where required by Engineer-in-Charge or as indicated on the plans, the rock shall be cut to form rough steps or benches to provide roughness or a more suitable bearing surface.

Rock foundation stratum shall be prepared by picking, barring, wedging and similar methods which will leave the rock in an entirely sound and unshattered condition.

Shortly before concrete is placed, the rock surface shall be cleaned with high pressure water and air jet even though it may have been previously cleaned in that manner.

Prior to placing concrete, the rock surface shall be kept wet for a period of 2 to 4 hours unless otherwise directed by the Engineer-in-Charge.

Before placing concrete on rock surfaces, all water shall be removed from depressions to permit through inspection and proper bonding of the concrete to the rock.

### **6.22 PREPARATION OF EARTH STRATA OF FOUNDATIONS:**

All earth surfaces upon which or against which concrete is to be placed, shall be well compacted and free from standing water, mud or debris. Soft, yielding soils shall be removed and replaced with suitable earth and well compacted as directed by the Engineer-in-Charge. Where specified, lean concrete shall be provided in the earth stratum for receiving concrete. The surface of absorptive soil against which concrete is to be placed shall be moistened thoroughly so that no moisture will be drawn from the freshly placed concrete and later shall help to cure the concrete.

### **6.23 PREPARATION OF CONCRETE SURFACES:**

Preparation of concrete surface upon which additional concrete is to be placed later, shall preferably be done by scarifying and cleaning while the concrete is between its initial and final set. This method shall be used wherever practicable and shall consist of cutting the surface with picks and stiff brooms and by use of an approved combination of air and water jet as directed by Engineer-in-charge. Great care shall be taken in performing this work to avoid removal of too much mortar and the weakening of the surface by loosening of aggregate. When it is not practicable to follow the above method, it will be necessary to employ air tools to remove laitance and roughen the surface.

The final required result shall be a pitted surface from which all dirt, unsound concrete, laitance and glazed mortar have been removed.

### **6.24 BONDING TREATMENT (MORTAR):**

After rock or concrete surfaces upon which new concrete is to be placed have been scarified, cleaned and wetted as specified herein, it shall receive a bonding treatment, immediately before placement of the concrete.

The bonding medium shall be a coat of cement sand mortar. The mortar shall have the same cement-

sand proportion as the concrete which shall be placed on it. The water cement ratio shall be determined by placing conditions and as approved by Engineer-in-Charge.

Bonding mortar shall be placed in sufficient quantity to completely cover the surface about 10 mm. thick for rock surface and about 5 mm. thick for concrete surfaces. It shall be brushed or broomed over the surface and worked thoroughly into all cracks, crevices and depressions. Accumulations or puddles of mortar shall not be allowed to settle in depressions and shall be brushed out to a satisfactory degree as determined by Engineer-in-Charge.

Mortar shall be placed at such a rate that it can be brushed over the surface just in advance of placement of concrete. Only as much area shall be covered with mortar as can be covered with concrete before initial set in the mortar takes place. The amount of mortar that will be permitted to be placed at any one-time, or the area which is to cover, shall be in accordance with Engineer-in-Charge.

#### **6.25 CLEANING AND BONDING OF FORMED CONSTRUCTION JOINTS:**

Vertical construction joints shall be cleaned as specified above or by other methods approved by Engineer-in-Charge. In placing concrete against formed construction joints, the surfaces of the joints, where accessible, shall be coated thoroughly with the specified bed-joint bonding mortar immediately before they are covered with concrete or by scrubbing with wire brooms, dipped into the fresh concrete. Where it is impracticable to apply such a mortar coating, special precautions shall be taken to ensure that the new concrete is brought into intimate contact with the surface of the joint by carefully puddling and spading with aid of vibrators and suitable tools.

#### **6.26 EXPANSION AND CONTRACTION:**

Provision shall be made for expansion and contraction in concrete by use of special type joints located as shown in the drawings. Construction joint surfaces shall be treated as specified in the specifications, shown in the drawings or as directed by Engineer-in-Charge.

#### **6.27 HOT WEATHER REQUIREMENTS:**

All concrete work performed in hot weather shall be in accordance with I.S. 456, except as herein modified.

Admixtures may be used only when approved by Engineer-in-Charge.

Adequate provision shall be made to lower concrete temperatures by cool ingredients, eliminating excessive mixing, preventing exposure of mixers and conveyers to direct sunlight and the use of reflective paint, on mixers etc. The temperature of the freshly placed concrete shall not be permitted to exceed  $23 \pm 2^{\circ}\text{C}$ .

Consideration shall be given to shading aggregate stock piles from direct rays of the sun and spraying stock piles with water, use of cold water available and burying, insulation, shading and/ or painting white the pipe lines and water storage tanks and conveyances.

In order to reduce loss of mixing water, the aggregates, wooden forms, subgrade, adjacent concrete and other moisture absorbing surfaces, shall be well wetted prior to concreting. Placement and finishing shall be done as quickly as possible.



Extra precautions shall be taken for the protection and curing of concrete. Consideration shall be given to continuous water curing and protection against high temperatures and drying hot wind for a period of at least 7 days immediately after concrete has set and after which normal curing procedures may be resumed.

#### **6.28 PLACING CONCRETE UNDER WATER:**

Under all ordinary conditions all foundations shall be completely dewatered and concrete placed in the dry. However, when concrete placement under water is necessary, all work shall conform to I.S.456 and procedure shall be as follows:

**Method of Placement:** Concrete shall be deposited under water by means of tremies or drop bottom buckets of approved type.

#### **6.29 DIRECTION, INSPECTION AND APPROVAL:**

All work requiring placement of concrete underwater shall be designed, directed and inspected with regard to the local circumstances and purposes. All under water concrete shall be placed according to the plans or specifications and as directed and approved by Engineer-in-Charge.

#### **6.30 SLOTS, OPENINGS ETC.:**

Slots, openings or holes, pockets etc. shall be provided in the concrete work in the positions indicated in the drawings or as directed by the Engineer-in-Charge. Any deviation from the approved drawings shall be made good by contractor at his own expenses without damaging any other work. Sleeves, bolts, inserts etc. shall also be provided in concrete work where so specified.

#### **6.31 PLAIN CEMENT CONCRETE FOR GENERAL WORK:**

For plain cement concrete work, the specification for materials viz. cement, sand, fine and coarse aggregates and water shall be the same as that specified in reinforced concrete work specification.

But the proportion of mix will be nominal and the ratio of fine and coarse aggregate may be slightly adjusted within limits, keeping the total value of aggregates to a given volumes of cement constant to suit the sieve analysis of both the aggregates. Cement shall on no account be measured by volume, but it shall always be used directly from the bags (i.e. 50 kg/bag).

The quantity of water used shall be such as to produce concrete of consistency required by the particular class of work and shall be decided by the use of a slump cone. Sufficient care should be taken to see that no excess quantity of water is used. The final proportion of the aggregate and quantity of water shall be decided by the Engineer-in-charge on the basis of test in each case.

Mix proportion Ordinary mix in volume	Cement in bags	Sand in cum	Coarse Aggregate in CUM			Water
			40 mm	20 mm	12 mm	
1:5:10	2.60	0.475	0.6623	0.2583	-	156
1:4:8	3.40	0.500	0.6883	0.6883	-	153
1:3:6 (with 40mm aggr.)	4.4	0.485	0.672	0.672	0.262	176
1:3:6 (with 20 mm aggr.)	4.4	0.485	-	0.727	0.242	162.5
1:2:4 (with 20 mm aggr.)	6.4	0.47	-	0.705	0.235	205
1:2:4 (with 40 mm aggr.)	6.4	0.47	0.544	0.241	0.126	235
1:1.5:3	8.0	0.441	-	0.6615	0.2205	240
1:1:2	12.20	0.45	-	0.675	0.225	330

The slump shall be specified for each class of work and shall in general be as follows:

Type of concrete	Max. slump (in mm.)
Mass concrete	50
Concrete below water proofing treatment	50
Coping	25
Floor paving	50

All plain concrete should be preferably mixed in a drum type powder driven machine with a loading hopper which will permit the accurate measure of various ingredients. If hand mixing is authorised, it should be done on a water tight platform.

The mixing of each batch in the concrete mixer shall continue for not less than 1.5 minutes after the materials and water are in the mixer. The volume is mixed materials per batch shall not exceed the manufacturers rated capacity of the mixer. The mixer shall rotate at a peripheral speed of about 60 metres per minute.

Concrete shall be poured and consolidated in its final position within half an hour of mixing. The retempering of concrete which has partially hardened, that is remixing with or without additional cement aggregate or water shall not be permitted. Concrete of mix 1:3:6 and 1:2:4 will be required to be vibrated if specified and directed by the Engineer. In case of the thickness of concrete is more than 150 mm., it may be vibrated as directed by the Engineer.

The concrete shall be cured for 10 days in ordinary weather and 15 days in hot weather.

Measurements for the work done shall be exact length, breadth and depth shown in figures on the drawings or as directed by the Engineer and after the concrete is consolidated. No extra shall be paid for excess quantity resulting from faulty workmanship.

### **6.32 SPECIFIC REQUIREMENTS FOR CONCRETE AND ALLIED WORKS:**

The following specific requirements shall be met within addition to those provided in the clause of specification for Concrete and allied works.

**6.32.1 Water:** Clean water in pipes under pressure shall be provided by the contractor with all necessary equipment for giving a nozzle pressure of not less than 2.0 kg/ sqcm. for the convenient and effective jetting of rock foundations and concrete surfaces, for cooling aggregate required for concrete, for curing concrete and other requirements.

**6.32.2 Fire Protection System:** The contractor shall provide and maintain at all times in adequate fire protection system to protect his equipment, materials and construction In case of an emergency, the contractor shall permit the Engineer-in-Charge to use the system for protecting equipment, works etc. on the project.

**6.32.3 Concrete:** The rates for all concrete work should be based as per specifications and taking into consideration the guidelines indicated in special instruction under relevant clause.

**6.32.4 The Placement Intervals:** Each placement of concrete shall be allowed to set for a period of 48 hours and longer when required, before the start of subsequent placement. A time gap between the two adjoining pours in the horizontal plane and the two adjacent pours in the vertical plane shall be 7 days and 3 days respectively.

### **6.32.5 Finishing of Concrete:**

**a) General:** Unless otherwise specified, concrete finishes shall conform to the following specifications:

Finish F1, F2 and F3 shall describe formed surface.

Finish U1, U2 and U3 shall describe un-formed surface.

Off sets or fins caused by disposed or misplaced form sheathing lining or form sections or by defective form lumber shall be referred to as abrupt irregularities. All other irregularities shall be referred to as gradual irregularities. Gradual irregularities shall be measured as deviation from a plane surface with a template 1.5 m. long for formed surface and 3 m. long for unformed surfaces.

### **b) Formed Surfaces:**

**Finish F1**-shall apply to all formed surfaces for which finish F2, F3 or any other special finish is not specified and shall include filling up all form tie holes.

**Finish F2**-shall apply to all formed surfaces so shown on the drawings or specified by the Engineer-in-Charge. This shall include filling all form tie-holes, repair of gradual irregularities exceeding 6 mm, removal of ridges and abrupt irregularities by grinding.

**Finish F3**-shall apply to all formed surfaces exposed to view or where shown in the drawings or specified by the Engineer-in-Charge. Finish F3 - shall include all measures specified for Finish-F2 and in addition, Filling air holes with mortar and treatment of the entire surface with sack rubbed finish. It shall also include clean-up of loose and adhering debris. Where a sack rubbed finish is specified, the surfaces shall be prepared within two days after removal of the forms.

The surface shall be wetted and allowed to dry slightly before mortar is applied by sack rubbing. The mortar used shall consist of one part cement to one and half parts by volume of fine (minus No. 16 mesh) sand. Only sufficient mixing water to give the mortar a workable consistency shall be used. The mortar shall then be rubbed over the surface with a fine burlap or linen cloth so as to fill all the surface voids. The mortar rubbed in the voids shall be allowed to stiffen and solidify after which the whole surface shall be wiped clean so that the surface presents a uniform appearance without air holes, irregularities etc.

Curing of the surface shall be continued for a period of ten (10) days.

#### **c) Unformed Surfaces:**

**Finish U1**-shall apply to all unformed surfaces for which the finish U2, U3 or any other special finish is not specified and shall include screeding the surface of the concrete to the required slope and grade. Unless the drawing specifies a horizontal surface or shows the slope required, the tops of narrow surfaces such as stair, treads, walls, curbs and parapets shall be sloped approximately 10 mm. per 300 mm. width. Surfaces to be covered by backfill or concrete sub-floors to be covered with concrete topping, terrazzo and similar surfaces shall be smooth screeded and leveled to produce even surface, irregularities not exceeding 6 mm.

**Finish U2**-shall apply to all unformed surfaces as shown in the drawing or specified by the Engineer-in-Charge and shall include screeding and applying a wood float finish to the surface of the concrete to the required slopes and grade.

Repair of abrupt irregularities unless a roughened texture is specified. Repair of gradual irregularities exceeding 6 mm.

**Finish U3**-shall apply to unformed surfaces for which a high degree of surface smoothness is required, where shown on the drawing or specified by the Engineer-in-Charge. This shall include screeding, floating and applying a steel trowel finish to the surface of the concrete to the required slopes and grade.

Repair of abrupt irregularities.

Repair of gradual irregularities exceeding 6 mm, finishing joints and edges of concrete with edging tools.

#### **6.33 MODE OF MEASUREMENT FOR CONCRETE WORK:**

**General:** Concrete as actually done shall be measured for payment, subject to the following tolerances, unless otherwise stated hereinafter. Any work done extra over the specified dimensions

shall not be measured for payment.

a) Linear dimensions shall be measured in full centimetres except for the thickness of slab which shall be measured to the nearest half centimetre.

b) Areas shall be worked out to the nearest 0.01 sqm.

c) Cubic contents shall be worked out to the nearest 0.001 cum.

d) The concrete shall be measured for its length, breadth and height/ depth limiting dimensions to those specified on drawings or as directed by the Engineer-in-Charge.

**NOTE:** The sizes of RCC members as assumed in the estimate are based on preliminary drawings and are likely to be changed. The contractor is not entitled to any extra claim due to such changes.

**Deductions:**

No deductions shall be made for the following:

a) Ends of dissimilar materials e.g. joists, beams, posts, girders, rafters, purlins, trusses, corbels, steps etc. upto 500 sq cm. in cross section.

b) Opening upto 0.1 sqm. (1000 sq cm)

c) Volume occupied by reinforcement.

d) Volume occupied by pipes, conduits, sheathing etc. not exceeding 25 sq cm. each in cross sectional area. Nothing extra shall be paid for leaving and finishing such cavities and holes.

**i) COLUMN FOOTING:**

R.C.C. in foundation and footings shall be measured for its length, breadth and depths limiting dimensions to those specified in drawing or as ordered in writing by the Engineer-in-Charge. In case of tapering portions of column footings, the quantities shall be calculated by the Formula: **Volume V = H/3 x [ A1 + A2 + sqrt {A1 x A2}]** ; where A1 = Area at top of footing, A2 = Area at bottom of footing and H = Height of footing.

**ii) COLUMN:**

Column shall be measured from top of footings to the plinth level and from plinth level to the structural slab level and to the subsequent structural slab levels. Measurements for higher grade concrete in columns at its junction with lower grade concrete beams shall be restricted to the column section supporting the beam in question.

**iii) WALL:**

All walls shall be measured from top of the wall footing to the plinth level and from plinth level to the top of structural first floor and to subsequent floors.

**iv) BEAM AND LINTEL:**

Beam shall be measured from face to face of the columns, walls, cross beams including haunches if any. The depth of the beams shall be measured from the top of the slab to the bottom of the beam except in the case of inverted beam where it shall be measured from top of slab to top of beams. The beams and lintels with narrow width even though acting as fascia in elevation in some cases, will be measured as beams and lintels only.

**v) SLAB:**

The length and breadth of slab laid to correct thickness as shown in the detailed drawings or as ordered by the Engineer-in-Charge shall be measured between beams, walls and columns.

**vi) CHAJJAS, FACIAS, FINS AND MULLIONS:**

a) Chajjas shall be measured net from supporting faces up to the edges of chajjas without any fascia.

b) Fascia shall be measured full excluding chajja thickness.

c) End fins shall be measured full.

d) Intermediate fins, mullions shall be measured between chajjas or other supporting structural members.

e) Parapets shall be measured from top of slab/ chajja.

**vii) STAIRCASE:**

The concrete in all members of staircase like waist slabs, steps, cantilever steps, stringer beams etc. shall be measured for their length, breadth and depth, limiting dimensions to those specified on drawings. No deductions shall be made for embedded plugs, pockets.

**Rates:** The rate for P.C.C/ R.C.C. shall include the cost of all materials, labour, transport, tools and plants and all the operations mentioned herewith, including or excluding the cost of form work and/ or reinforcement as mentioned in the of quantities. The rates also shall include the cost of testing materials, mix design, cube test and allied incidental expenses.

## **VII. READY MIX CONCRETE:**

### **(SPECIFICATIONS FOR READY MIXED CONCRETE, CONFORMING TO IS-4926)**

**7.1 Ready mix Concrete shall conform to latest revision of IS: 4926 following are the requirement for supply of R.M.C**

**7.1.1** Concrete delivered at site shall be in a plastic condition and requiring no further treatment before being placed in the position in which it is to set and harden

**7.1.2** The process of continuing the mixing of concrete at a reduced speed during transportation to prevent segregation.

**7.1.3** Truck mounted equipment designed to agitate concrete during transportation to the site of delivery.

**7.1.4** Concrete produced by completely mixing cement, aggregates, admixtures if any and water at a stationary central mixing plant and delivered in containers fitted with agitating devices. The concrete may also be transported without being agitated as a special case and as requested.

**7.1.5** Concrete produced by placing cement, aggregates and admixtures, if any other than those to be added with mixing water, in a truck mixer at the batching plant, the addition of water and admixtures to be added along with mixing water, and the mixing being carried out entirely in the truck mixer either during the journey or on arrival at the site of delivery. No water shall be added to the aggregate and cement until the mixing of concrete commences.

### **7.2. MATERIALS:**

**7.2.1** The cement used shall be of specified grade ordinary Portland cement or low heat Portland cement conforming to IS: 269 or Portland slag cement conforming to IS: 455 or Portland-pozzolana cement conforming to IS: 1489 or rapid hardening. Portland cement conforming to IS: 8041 as may be specified at the time of placing the order. If the type is not specified, ordinary Portland cement shall be used.

**7.2.2 Fly ash** when used for partial replacement of cement, shall conform to the requirements of IS-3812 (Part I) and as specified by the users.

**7.2.3 The aggregate** shall conform to IS: 383. Fly ash when used as fine aggregate shall conform to the requirements of IS 3812 – (Part - II).

**7.2.4 Water** used for concrete shall conform to the requirement of IS 456-2000.

**7.2.5 The admixtures** shall conform to the requirements of IS: 456-2000 and their nature, quantities and methods of use shall also be specified. Fly ash when used as an admixture for concrete shall conform to IS: 3812 (Part II) – 1981. However, partial replacement of cement by fly ash shall not be more than 15% of designed requirement.

In case if fly ash is used more than 15%, the same shall be guided under table 5.1 of the IS, and in which case specific care shall be taken in terms of curing, protecting, repairing, finishing, de-

shuttering etc. as detailed in the Chapter “FLY ASH CONCRETE”, here in after.

### **7.3. SUPPLY:**

The ready-mixed concrete shall be manufactured and supplied on either of the following basis:

- i) Specified strength based on 28-day compressive strength of 15 -cm cubes tested in accordance with IS: 456-2000.
- ii) Specified mix proportion.

**NOTE:** Under special circumstances and as specified the strength of concrete in (a) above may be based on 28-day or 7-day flexural strength of concrete instead of compressive strength of 15-cm cube tested in accordance with IS: 456-2000.

**7.3.1** When the concrete is manufactured and supplied on the basis of specified strength, the responsibility for the design of mix shall be that of the manufacturer and the concrete shall conform to the requirements specified.

**7.3.2** When the concrete is manufactured and supplied on the basis of specified mix proportions, the responsibility for the design of the mix shall be that of the purchaser and the concrete shall conform to the requirements specified.

### **7.4. GENERAL REQUIREMENTS:**

**7.4.1** When a truck mixer or agitator is used for mixing or transportation concrete, no water from the truck-water system or from elsewhere shall added after the initial introduction of the mixing water for the batch, when no arrival at the site of the work, the slump of the concrete is less that specified, such additional water to bring the slump within limits shall be injected into the mixer under such pressure and direct flow that the requirements for uniformity specified.

**7.4.2** Unless otherwise specified when a truck or agitator is used for transporting concrete, the concrete shall be delivered to the site of the work and discharge shall be complete within 1 ½ hour (when the prevailing atmospheric temperature above 20°C) and within 2 hours (when the prevailing atmosphere temperature is at or below 20°C) of adding the mixing water to the mix of cement and aggregate or adding the cement to the aggregate whichever is earlier.

**7.4.3** The temperature of the concrete at the place and time of delivery shall be not less than 5°C. Unless otherwise required by the purchaser.

**7.4.4** Adequate facilities shall be provided by the manufacturer/supplier to inspect the materials used the process of manufacture and methods of delivery of concrete. He shall also provide adequate facilities to take samples of the materials used.

**7.4.5** The tests for consistency or workable shall be carried out in accordance with requirements of IS 1199 by such other method as may be agreed to between the purchaser and manufacturer.

**7.4.6** The sampling and testing of concrete shall be done in accordance with the relevant requirements of IS 456, IS 1199 and IS 516.



**7.4.7** The compressive strength and flexural strength tests shall be carried out in accordance with the requirement of IS: 516 and the acceptance criteria for concrete whether supplied on the basis of specified strength or on the basis of mix proportion, shall conform to the requirements and other related requirements of IS: 456 -2000.

**7.4.8** The testing shall be carried out in accordance with the requirements and the cost shall be borne by the Contractor.

**7.4.9** The manufacturer shall keep batch records of the quantities by mass all the solid materials, of the total amount of water used in mixing and of the results of all tests. If required insisted, the manufacturer shall furnish certificates, at agreed intervals, giving this information.

**7.4.10** Mode of measurement for ready mixed concrete (RMC) will be the same as mode of measurement for concrete work already mentioned at page No. 42 & 43 of clause 4.40. However, consumption of RMC shall be maintained at site. Wastage, spillover, wastage due to pump blockage etc. shall not be considered for payment.

## **7.5 FLY ASH CONCRETE:**

### **NOTES:**

- a) The fly ash should have consistent quality satisfying the requirements of Grade-1 FA of IS 3812 and Class-F of ASTM C-618.
- b) The source of fly ash should be so selected that test results of fly ash samples collected from these sources during last one year at frequency of maximum one month interval should satisfy the requirements of above codes.
- c) The characterization of fly ash which will be used should be done as per above two codes for each batch of fly ash.
- d) The fly ash should be stored in bins at the plant.
- e) All concrete should be manufactured at RMC plant.
- f) The mix proportion should be approved by competent authority. The information to be supplied for approval would be identified by the competent authority.
- g) Any change in mix proportion, after approval, should be concurred by appropriate authority.
- h) Samples to be taken, at each time of casting, for 7 days and 28 days.
- i) All ingredients of concrete should satisfy the requirements of relevant IS codes and specifications.

### **7.5.1 Curing, Protecting, Repairing and Finishing:**

**7.5.1.1 Curing:** All concrete shall be cured by keeping it continuously damp for the period of time required for complete hydration and hardening to take place. Preference shall be given to the use of continuous sprays or ponded water, continuously saturated covering of sacking, canvas, hessain or other absorbent materials, or approved effective curing compounds applied with spraying equipment capable of producing a smooth, even textured coat. Extra precautions shall be exercised in curing concrete during cold and hot weather as outlined hereinafter the quality of curing water shall be the same as that used for mixing concrete.

Certain types of finish or preparation for overlaying concrete must be done at certain stages of curing process and special treatment may be required for specific concrete surface finish.

Curing of concrete made of high alumina cement and super sulphated cement shall be carried out as directed by Engineer-in-charge.

**7.5.1.2** Curing of concrete with low water binder ratios having partial replacement of cement by pozzolanic materials.

**7.5.1.3** The structural elements with concrete having water binder ratio less than or equal to 0.4 or partial replacement of cement by pozzolanic materials (5% or above replacement by silica fume or high reactivity metakaolin, or 15% or above by fly ash) shall be cured in two stages, initial curing and final curing.

- i) The initial curing should be started not later than 3 hours or initial setting time, whichever is lower, after placement of concrete. The concrete surface exposed to environment should be covered by plastic sheet or other type of impermeable covers. The initial curing should be continued upto a minimum period of 12 hours or 2 hours plus final setting time of concrete, whichever is higher.
- ii) Final curing should be done with water. It should commence immediately after initial curing and continue upto a minimum period of 14 days.

#### **7.5.1.4 Curing with Water**

Fresh concrete shall be kept continuously wet for a minimum period of 14 days from the date of placing of concrete, following a lapse of 12 to 24 hours after laying concrete. The curing of horizontal surfaces exposed to the drying winds shall however begin immediately the concrete has hardened. Water shall be applied to uniformed concrete surfaces within 1 hour after concrete has set. Water shall be applied to formed surfaces immediately upon removal of forms. Quantity of water applied shall be controlled so as to prevent erosion of freshly placed concrete.

#### **7.5.1.5 Continuous Spraying**

Curing shall be assured by use of ample water supply under pressure in pipes, with all necessary appliances of hose sprinklers and spraying devices. Continuous fine mist spraying or sprinkling shall be used, unless otherwise specified or approved by Engineer-in-charge.

#### **7.5.1.6 Alternate Curing Methods:**

Whenever in the judgement of Engineer-in-charge, it may be necessary to omit the continuous spray method, covering of clean sand or other approved means such as wet gunny bags, which will prevent loss of moisture from the concrete, may be used. Any type of covering which would slain or damage the concrete during or after the curing period, will not be permitted. Covering shall be kept continuously wet during the curing period.

For curing of concrete in pavements, side-walks, floors, flat roofs or other level surfaces, the ponding method of curing is preferred. The method of containing the ponded water shall be approved by Engineer-in-charge. Special attention shall be given to edge and corner of the slab to ensure proper protection to these areas. The ponded areas shall be kept continuously filled with water during the curing period.

**7.5.1.7 Curing Compounds:** Surface coating type curing compound shall be used only on special permission of Engineer-in-charge. Curing compounds shall be liquid type while pigmented, conforming to U.S Bureau of Reclamation Specification. No curing compound shall be used on surface where future blending with concrete water or acid proof membrane or painting is specified.

**7.5.1.8 Curing Equipment:** All equipment's and materials required for curing shall be on hand and ready for use before concrete is placed.

**7.5.1.9 Mass Concrete Temperature Control Method:** To keep the temperature difference between concrete core and concrete surface  $<20^{\circ}\text{C}$ , and to keep maximum concrete temperature  $< 25^{\circ}\text{C}$ , necessary steps are needed. Where in this work is divided into 2 steps namely precooling and post cooling.

**7.5.1.10**

Sl. No.	Mixed design with a mixture of fly ash and cold water	(Precooling):
1	Use mix design with the following mixture so that the concrete can be lowered. Mix design for M25:	initial temperature of the
2	Water Cement Ratio	: 0.43
3	Cement	: 270 kg
4	Fly Ash	: 80 kg (30%)
5	Sand	: 839 kg
6	Gravel	: 1109 kg
7	Water	: 150 kg
8	Water temperature (used ice water)	: 7 'C
9	Slump	: 10 ± 2 cm
10	Admixture: Type D: 0.72 kg, Type F	: 4.1 kg

**Note:** The contractor has to submit the mix design after vetting from JNTU orequivalent university.

**7.5.1.11 Surface Insulation (Post Cooling):** Surface insulation is performed as soon as the



concrete surface hardened (1.5 hours of concrete pour time). Surface insulation is done by covering the surface area of concrete with a layer of plastic, 2 cm Styrofoam or wet sand with a thickness of 20cm. Surface insulation is performed for 14 days, or after concrete temperature difference  $< 20^{\circ}\text{C}$ . After surface insulation is removed, proceed with curing using water or wetted cloth.

**VIII. GROUTING:**

**8.1 Standard Grout: Grout shall be provided as specified in the drawing.**

The proportions of grout shall be such as to produce a flowable mixture consistent with minimum water content and shrinkage. The grout proportions shall be limited as follows:

Use	Grout thickness	Mix. proportions	W/C. Ratio in (Max.)
a) Fluid mix	Under 25 mm.	One part Portland cement to one part sand.	0.44
b) General	25 mm. and over but less than 50 mm.	One part Portland cement to 2 parts of sand.	0.53
c) Stiff mix.	50 mm. and over	One part Portland cement to 3 parts of sand.	0.53

Sand shall be such as to produce a flowable grout without any tendency to segregate. Sand, for general grouting purposes, shall be graded within the following limits:

Passing I.S. sieve 2.36 mm.	95 to 100%
Passing I.S. sieve 1.18 mm.	65 to 95%
Passing I.S. sieve 300 micron above	10 to 30%
Passing I.S. sieve 150 micron above	3 to 10%

Sand for fluid grouts shall have the fine material passing the 300 and 150 micron sieves at the upper limits specified above.

Sand for stiff grouts, shall meet the usual grading specifications and concrete.

Surface to be grouted shall be thoroughly roughened and cleaned of all foreign matter and laitance.

Anchor bolts, anchor bolt holes and bottom of equipment and column base plates shall be cleaned of all oil, grease, dirt and loose material. The use of hot, strong, caustic solution for this purpose will be permitted.

Prior to grouting, the hardened concrete surfaces to be grouted, shall be saturated with water.

Water in anchor bolt holes shall be removed before grouting is started.

Forms around base plates shall be, reasonably, tightened to prevent leakage of the grout.

Adequate clearance shall be provided between forms and base plate to permit grout to be worked properly into place.

Grouting, once started shall be done quickly and continuously to prevent segregation, bleeding and breakdown of initial set. Grout shall be worked from one side of one end to the other to prevent

entrapment of air. To distribute the grout and to ensure more release from entrapped air, link chains can be used to work the grout into place.

Grouting through holes in base plate shall be by pressure grouting.

Variations in grout mixes and procedures shall be permitted if approved by the Engineer-in-Charge.

**8.2 Special Grout:** Special grout where specified on the drawing shall be provided in strict accordance with the manufacturer's instructions/ specifications on the drawings.

### **8.3 INSPECTION:**

All materials, workmanship and finished construction shall be subject to the continuous inspection and approval of Engineer-in-Charge.

All rejected materials supplied by contractor and all rejected work or construction performed by contractor, as is not in conformance with the specifications and drawings, shall immediately be replaced at no additional expense to the Department.

Approval of any preliminary material or phase of work shall in no way relieve the contractor from the responsibility of supplying concrete and/ or producing finished concrete in accordance with the specifications and drawings.

All concrete shall be protected against damage until final acceptance by the Department or its representatives.

### **8.4 CLEAN UP:**

Upon the completion of concrete work, all forms, equipments, construction tools, protective coverings and any debris resulting from the work shall be removed from the premises.

All debris i.e. empty containers, scrap wood etc. shall be removed to dump daily or as directed by the Engineer-in-Charge.

The finished concrete surfaces shall be left in a clean condition to the satisfaction of the Engineer-in-Charge.

## **IX. STEEL FOR CONCRETE REINFORCEMENT :**

### **9.1 SCOPE OF MATERIAL:**

The contractor shall make his own arrangement for procurement of Reinforcement steel bars and wires for use in Reinforced Cement Concrete works. Unless otherwise specified in drawings / Schedule of quantities, the steel bars shall be of “High strength deformed steel bars and wires” conforming to the IS 1786 (latest revision), in the following strength grades:

- a) Fe 415, Fe 415D;
- b) Fe 500, Fe 500D;
- c) Fe 550, Fe 550D; and
- d) Fe 600.

Where “**Fe**” stands for specified minimum 0.2% proof / yield stress in N/mm<sup>2</sup> and “**D**” stands for same specified minimum 0.2% proof / yield stress but with enhanced specified minimum percentage elongation.

### **9.2 TERMINOLOGY:**

**Elongation:** The increase in length of a tensile test piece under stress, expressed as a percentage of the original gauge of a standard piece.

**Longitudinal Rib** -A uniform continuous protrusion, parallel to the axis of the bar/wire (before cold-working, if any).

**Nominal Diameter or Size-** The diameter of a plain round bar/wire having the same mass per metre length as the deformed bar/wire.

**Nominal Mass** -The mass of the bar/wire of nominal diameter and of density 0.00785 kg/cumm per meter.

**Nominal Perimeter** - 3.14 times the nominal diameter of a deformed bar/Wire.

**Percent Proof Stress** -The stress at which a non-proportional elongation equal to 0.2% of the original gauge length takes place.

**Uniform elongation** - The elongation corresponding to the maximum load reached in a tensile test (also termed as percentage total elongation at maximum force).

**Tensile Strength** - The maximum load reached in a tensile test divided by the effective cross-sectional area of the gauge length portion of the test piece (also termed as ultimate tensile stress).

**Transverse Rib** - Any rib on the surface of a bar/wire other than a longitudinal rib.

**Yield Stress** - Stress (that is, load per unit cross sectional area) at which elongation first occurs in the test piece without increasing the load during the tensile test. In the case of steels with no such definite yield point, proof stress shall be applicable.

The high strength deformed steel bars and wires for concrete reinforcement shall be hot rolled steel without subsequent treatment or hot rolled steel with controlled cooling and tempering and cold

worked steel, and reinforcing bars and wires which may be subsequently coated.

Steel bars shall be supplied from M/s. Steel Authority of India Ltd. (SAIL) or M/s. TATA Steel (TISCO) or M/s. Rashtriya Ispat Nigam Ltd (RINL) or M/s. Indian Iron & Steel Co. (IISCO) Ltd., from their own plants rolled from virgin material, and shall be procured directly or from their authorized dealers and not from re-rollers or conversion agents. The contractor shall supply copy of Documentary evidence of purchase of steel from the specified manufacturers.

### **9.3 TESTS:**

The contractor shall submit the test certificate of manufacturer. Regular tests on steel supplied by the contractor shall be performed by the contractor at the approved lab, in presence of the Departmental Engineers as per relevant Indian Standards. Engineer-in-charge may require Contractor to perform necessary tests of samples at random as per relevant B.I.S. All cost of such tests and incidentals to such tests shall be borne by the Contractor. The quality, grade, colour coding embossing marks etc. all shall be to the entire satisfaction of the Engineer-in-Charge. Steel not conforming to above test criteria shall be rejected.

The Chemical, Physical & Mechanical properties of the steel reinforcement bars shall be as per IS 1786. Unless otherwise specified, Selection and Preparation of Test Sample shall be as per the requirements of IS 2062.

All test pieces shall be selected either from the cuttings of bars / wires; or from any bar/wire after it has been cut to the required or specified size and the test piece taken from any part of it. In neither case, the test piece shall be detached from the bar/wire except in the presence of the EIC or his authorized representative.

The test pieces shall be full sections of the bars/wires and shall be subjected to physical tests without any further modifications. No reduction in size by machining or otherwise shall be permissible, except in case of bars of size 28 mm and above. No test piece shall be annealed or otherwise subjected to heat treatment. Any straightening which a test piece may require shall be done cold.

For the purpose of carrying out tests for tensile strength, proof stress, percentage elongation and percentage elongation at maximum force for bars 28 mm in diameter and above, deformations of the bars only may be machined. For such bars, the physical properties shall be calculated using the actual area obtained after machining. The following IS codes shall be referred for test methods:

<b>S.N</b>	<b>Title</b>	<b>IS No</b>	<b>ISO No.</b>
i	Mechanical testing of metals -Tensile testing	1608	6892
ii	Methods for bend test	1599 7438 & 1786	15630-1
iii	Method for re-bend test for metallic wires & bars	1786	15630-1



**THE PROPERTIES AS PER IS 1786 – 2008 ARE REPRODUCED BELOW:**

**Chemical Composition of the bars shall conform to the following requirement:**

Constituents	Maximum Permissible Percent							Permissible max. Variation
	Fe 415	Fe 415D	Fe 500	Fe 500D	Fe 550	Fe 550D	Fe 600	
Carbon	0.300	0.250	0.300	0.250	0.300	0.250	0.300	0.020%
Sulphur	0.060	0.045	0.055	0.040	0.055	0.040	0.040	0.005%
Phosphorus	0.060	0.045	0.055	0.040	0.050	0.040	0.040	0.005%
Sulphur & Phosphorus	0.110	0.085	0.105	0.075	0.100	0.075	0.075	0.010%

**Notes:**

- i) For welding of deformed bars, the recommendations of IS 9417 shall be followed.
- ii) In case of deviations from the specified maximum, two additional test samples shall be taken from the same batch and subjected to the test or tests in which the original sample failed. Should both additional test samples pass the test, the batch from which they were taken shall be deemed to comply with this standard. Should either of them fail, the batch shall be deemed not to comply with this standard

**Mechanical Properties of High Strength Deformed Bars and Wires**

Sl. No.	Property	Maximum Permissible Percent						
		Fe 415	Fe 415D	Fe 500	Fe 500D	Fe 550	Fe 550D	Fe 600
1	2	3	4	5	6	7	8	9
i	0.2 percent proof stress / yield stress, Min, N/mm <sup>2</sup>	415.0	415.0		500.0	550.0	550.0	600.0
ii	Elongation, percent, Min. on gauge length $5.65 \sqrt{A}$ , where A is the Cross – sectional area of the test piece	14.5	18.0	12.0	16.0	10.0	14.5	10.0
iii	Tensile strength, Min	10% more than the actual 0.2% proof stress/yield stress but not less than	12% more than the actual 0.2% proof stress/yield stress but not less than	8% more than the actual 0.2% proof stress/yield stress but not less than	10% more than the actual 0.2% proof stress/yield stress but not less than	6% more than the actual 0.2% proof stress/yield stress but not less than	8% more than the actual 0.2% proof stress/yield stress but not less than	6% more than the actual 0.2% proof stress/yield stress but not less than

		485.0 N/mm <sup>2</sup>	500.0 N/mm <sup>2</sup>	than 1805.0 N/mm <sup>2</sup>	565.0 N/mm <sup>2</sup>	than 585.0 N/mm <sup>2</sup>	600.0 N/mm <sup>2</sup>	than 660.0 N/mm <sup>2</sup>
iv	Total elongation at maximum force, percent, Min of gauge length $5.65 \sqrt{A}$ , where A is the cross sectional area of the test piece	-	5	-	5	-	5	-

**Note:** To satisfy Clause 26 of IS 456 -2000, no mixing of different types of grades of bars shall be allowed in the same structural members as main reinforcement, without prior written approval of the Engineer-in-Charge.

**9.4 STACKING & STORAGE:**

Steel for reinforcement shall be stored in such a way as to prevent distorting and corrosion. The steel for reinforcement shall not be kept in direct contact with ground. Fresh / Fabricated reinforcement shall be carefully stored to prevent damage, distortion, corrosion and deteriorations. Care shall be taken to protect steel from exposure to saline atmosphere during storage, fabrication and use. It may be achieved by treating the surface of reinforcement with cement wash or by suitable methods. Bars of different classifications, sizes and lengths shall be stored separately to facilitate issue in such sizes and lengths to cause minimum wastage in cutting from standard length.

**9.5 QUALITY:**

Steel not conforming to specifications shall be rejected. All reinforcement shall be clean, free from grease, oil, paint, dirt, loose mill, scale, loose rust, dust, bituminous material or any other substances that will destroy or reduce the bond. All rods shall be thoroughly cleaned before being fabricated. Pitted and defective rods shall not be used. All bars shall be rigidly held in position before concreting. No welding of rods to obtain continuity shall be allowed unless approved by the Engineer-in-Charge. If welding is approved, the work shall be carried as per I.S. 2751, according to best modern practices and as directed by the Engineer-in-Charge. In all cases of important connections, tests shall be made to prove that the joints are of the full strength of bars welded. Substitution of reinforcement will not be permitted except upon written approval from Engineer-in-charge.

**9.6 NOMINAL SIZES**

The nominal sizes of bars/wires shall be 4mm, 5mm, 6mm, 8mm, 10mm, 12mm, 16mm, 20mm, 25 mm, 28mm, 32mm, 36mm, 40 mm. (Other sizes viz. 7mm, 18mm, 22 mm, 45 mm and 50 mm may be procured on specific stipulations).

**9.7 NOMINAL MASS**

For the purpose of checking the nominal mass, the density of steel shall be taken as 0.00785 kg/mm<sup>3</sup> of the cross-sectional area per meter. Unless otherwise specified, the tolerances on nominal mass

shall be as per following Table.

**Tolerances on Nominal Mass**

SN	Nominal Size in mm	Tolerance on the nominal mass in Percent		
		Batch	Individual sample	Individual sample for coils only
1	2	3	4	5
i)	Up to and including 10	± 7	- 8	± 8
ii)	Over 10 up to and including 16	± 5	- 6	± 6
iii)	Over 16	± 3	- 4	± 4

**9.8 LAPS:**

Laps and splices for reinforcement shall be shown on the drawings. Splices in adjacent bars shall be staggered and the locations of all splices, except those specified on the drawings, shall be approved by the Engineer-in-Charge. The bars shall not be lapped unless the length required exceeds the maximum available lengths of bars at site.

**9.9 BENDING:**

All bars shall be accurately bent according to the sizes and shapes shown on the detailed working drawing / bar bending schedules. They shall be bent gradually by machine or other approved means. Reinforcing bars shall not be straightened and re-bent in a manner that will injure the materials. Bars containing cracks or splits shall be rejected. They shall be bent cold, except bars of over 25 mm. in diameter which may be bent hot if specifically approved by the Engineer-in-Charge. Bars that depend for their strength on cold working shall not be bent hot. Bars bent hot shall not be heated beyond cherry red colour (not exceeding 645°C) and after bending shall be allowed to cool slowly with out quenching. Bars incorrectly bent shall be used only after straightening and re-bending be such as shall not, in the opinion of the Engineer-in-Charge, injure the material. No reinforcement bar shall be bent when in position in the work without approval, whether or not it is partially embedded in hardened concrete. Bars having kinks or bends other than those required by design shall not be used.

**BENDING AT CONSTRUCTION JOINTS:**

Where reinforcement bars are bent aside at construction joints and afterwards bent back into their original position, care should be taken to ensure that at no time the radius of the bend is less than 4 bar diameters for plain mild steel or 6 bar diameters for deformed bars. Care shall also be taken when bending back bars to ensure that the concrete around the bar is not damaged.

**9.10 FIXING / PLACING AND TOLERANCE ON PLACING:**

Reinforcement shall be accurately fixed by any approved means maintained in the correct position as shown in the drawings by the use of blocks, spacers and chairs as per I.S. 2502 to prevent displacement during placing and compaction of concrete. Bars intended to be in contact at crossing point shall be securely bound together at all such points with number 16 gauge annealed soft iron wire. The vertical distances required between successive layers of bars in beams or similar members shall be maintained by the provision of spacer bars at such intervals that the main bars do not perceptibly sag between adjacent spacer bars.

**TOLERANCE ON PLACING OF REINFORCEMENT:**

Unless otherwise specified, reinforcement shall be placed within the following tolerances:

	Tolerance in spacing
a) For effective depth, 200 mm or less	+ /- 10 mm
b) For effective depth, more than 200 mm	+ /- 15 mm

**9.11 COVER TO REINFORCEMENT:**

Nominal cover is the design depth of concrete cover to all steel reinforcements, including links. It is the dimension used in design and indicated in the drawings. It shall be not less than the diameter of the bar. Unless otherwise specified, cover to reinforcement shall be provided generally as per guidelines of IS 456.

**Nominal cover to meet durability requirement:**

Minimum values for the nominal cover of normal weight aggregate concrete which should be provided to all reinforcement, including links depending on the condition of exposure described in 4.4 above and as per (nominal cover to meet durability requirements).

However for a longitudinal reinforcing bar in a column nominal cover shall in any case not be less than 40 mm or less than the diameter of such bar. In the case of columns of minimum dimension of 200 mm or under, whose reinforcing bar do not exceed 12 mm , a nominal cover of 25 mm may be used.

For footings minimum cover shall be 50 mm.

Nominal cover to meet specified period of fire resistance

Minimum values of nominal cover of normal-weight aggregate concrete to be provided to all reinforcement including links to meet specified period of the resistance as per the tables given under clause 4.4.1 of this specifications.

The cover shall in no case be reduced by more than one third of specified cover or 5 mm whichever is less.

Unless indicated otherwise on the drawings, clear concrete cover for reinforcement (exclusive of plaster or other decorative finish shall be as follows:

- a) At each end of reinforcing bar not less than 25mm, nor less than twice the diameter of such, bar.
- b) For a longitudinal reinforcing bar not less than 25 mm, nor more than 40 mm, nor less than the diameter of such bar. In the case of column of maximum dimensions of 200 mm. or under, whose reinforcing bars do not exceed 12 mm, a cover of 25 mm. may be used.
- c) For longitudinal reinforcing bar in a beam, not less than 25mm, nor less than diameter of such bar.
- d) For tensile, compressive, shear, or other reinforcement in a slab, not less than 25 mm, nor

less than the diameter of such bar, and

e) For any other reinforcement not less than 15 mm, nor less than the diameter of such bar.

f) Increased cover thickness may be provided when surfaces of concrete members are exposed to the action of harmful chemicals (as in the case of concrete in contact with earth faces contaminated with such chemicals), acid, vapour, saline atmosphere, sulphurous smoke (as in the case of steam-operated railways) etc. and such increase of cover may be between 15 mm. and 50 mm. beyond the figures given in (a to e) above as may be specified by the Engineer-in-Charge.

g) For reinforced concrete members, totally immersed in sea water, the cover shall be 40 mm. more than specified (a to e) above.

h) For reinforced concrete members, periodically immersed in sea water or subject to sea spray, the cover of concrete shall be 50 mm. more than that specified (a to e) above.

i) For concrete of grade M 25 and above, the additional thickness of cover specified in (f), (g) and (h) above may be reduced to half. In all such cases the cover should not exceed 75 mm.

j) Protection to reinforcement in case of concrete exposed to harmful surroundings may also be given by providing dense impermeable concrete with approved protective coating, as specified on the drawings. In such case the extra cover, mentioned in (h) and (i) above, may be reduced by the Engineer-in-Charge, to those shown on the drawing.

k) The correct cover shall be maintained by cement mortar briquettes or other approved means. Reinforcement for footings, grade beams and slabs on subgrade shall be supported on precast concrete blocks as approved by the Engineer-in-Charge. The use of pebbles or stones shall not be permitted.

l) The minimum clear distance between reinforcing bars shall be in accordance with I.S. 456 or as shown in drawing.

#### **9.12 THE BARS SHALL BE KEPT IN CORRECT POSITION BY THE FOLLOWING METHODS.**

a) In case of beam and slab construction precast cover blocks in cement mortar 1:2 (1 cement: 2 coarse sand ) about 4 x 4 cm section and of thickness equal to the specified cover shall be placed between the bars and shuttering, so as to secure and maintain the requisite cover of concrete over reinforcement.

b) In case of cantilevered and doubly reinforced beams or slabs, the vertical distance between the horizontal bars shall be maintained by introducing chairs, spacers or support bars of steel at 1.0 metre or at shorter spacing to avoid sagging.

c) In case of columns and walls, the vertical bars shall be kept in position by means of timber templates with slots accurately cut in them; or with block of cement mortar 1:2 (1 cement: 2 coarse sand) of required size suitably tied to the reinforcement to ensure that they are in correct position during concreting.

d) In case of other R.C.C. structure such as arches, domes, shells, storage tanks etc. a combination of cover blocks, spacers and templates shall be used as directed by Engineer-in-Charge.

**9.13 INSPECTION:**

Erected and secured reinforcement shall be inspected and approved by Engineer-in-Charge prior to placement of concrete.

**9.14 MODE OF MEASUREMENT FOR REINFORCEMENT FOR R.C.C. WORKS:**

Reinforcement as detailed in schedule of quantities shall be measured for payment lineally as per the cutting length nearest to a centimeter shown in bar bending schedule submitted by the contractor and approved by the Engineer-in-Charge and weight calculated based on the standard weights as per I.S.1786, as indicated in the following table:

Nominal size in mm	6	7	8	10	12	16	18	20
Cross Sectional area in mm <sup>2</sup> .	28.30	38.50	50.30	78.60	113.10	201.20	254.60	314.30
Mass / Weight in Kg / RM	0.222	0.302	0.395	0.617	0.888	1.580	2.000	2.47
Nominal size in mm	22	25	28	32	36	40	45	50
Cross Sectional area in mm <sup>2</sup>	380.30	491.10	614.00	804.60	1018.30	1257.20	1591.10	1964.30
Mass / Weight in Kg / RM	2.980	3.850	4.830	6.310	7.990	9.850	12.500	15.420

No allowance shall be made/ be measured in the weight for rolling margin. If weight of bar(s) found to be more than the standard weights, the measurement / payment shall be restricted to the standard weights as above. However, if weight of bar(s) found to be less than the standard weights (but within the permissible limit), the measurements / payment for the same shall be as per standard weights.

Only authorized laps shall be measured. The cost of steel used by the contractor in the reinforcement of beams, slabs and columns etc. will be paid as per the rate of reinforcement only upto the extent shown in the drawings. As far as possible laps in bars shall be avoided. Any laps and hooks provided by the contractor other than authorized as per approved bar bending schedule will be considered to have been provided by the contractor for his own convenience and shall not be measured for payment. Pins, chairs, spacers shall be provided by the contractor wherever required as per drawing and bar bending schedule and as directed by the Engineer-in-Charge and shall be measured for payment. Fan hooks as required shall be provided by the contractor under this item and shall be measured for payment.

The rate shall include the cost of all materials and labour required for all above operations including transport, wastage, straightening, cutting, bending, binding and the binding wire required.

## **X. FORM WORK:**

### **GENERAL:**

The form work shall consist of shores, bracings, sides of beams and columns, bottom of slabs etc. including ties, anchors, hangers, inserts etc. complete which shall be properly designed and planned for the work. The false work shall be so constructed that up and down vertical adjustment can be made smoothly. Wedges may be used at the top or bottom of timber shores, but not at both ends, to facilitate vertical adjustment or dismantling of form work.

### **10.1 DESIGN OF FORM WORK:**

The design and engineering of form work as well as its construction shall be the responsibility of Contractor. If so instructed, the drawings and calculations for the design of the form work shall be submitted well in advance to the Engineer-in-Charge for approval before proceeding with work, at no extra cost to the Department. Engineer-in-Charges approval shall not however, relieve Contractor of the full responsibility for the design and construction of the form work. The design shall take into account all the loads vertical as well as lateral that the forms will be carrying including live and vibration loadings.

### **10.2 TOLERANCES:**

Tolerances are a specified permissible variation from lines, grade or dimensions given in drawings. No tolerances specified for horizontal or vertical building lines or footings shall be constructed to permit encroachment beyond the legal boundaries. Unless otherwise specified, the following tolerances will be permitted:

#### **10.2.1 Tolerances for R.C. Buildings:**

##### **i) Variation from the plumb:**

a) In the line and surfaces of columns, piers, walls and in buttresses: 5 mm. per 2.5 m., but not more than 25 mm.

b) For exposed corner columns and other conspicuous lines.

In any bay or 5 m. maximum: (+/-) 5 mm.

In 10 m. or more: (+/-) 10 mm.

##### **ii) Variation from the level or from the grades indicated on the drawings.**

a) In slab soffits, ceilings, beam soffits and in arises.

In 2.5 m.: (+/-) 5 mm.

In any bay or 5 m. maximum: (+/-) 8 mm.

In 10 m. or more: (+/-) 15 mm.

b) For exposed lintels, sills, parapets, horizontal grooves and other conspicuous lines.

In any bay or 5 m. maximum: (+/-) 15 mm.

In 10 m or more: (+/-) 10 mm.

**iii) Variation of the linear building lines from established position in plan and related position of columns, walls and partitions.**

In any bay or 5 m. maximum: (+/-) 10 mm.

In 10 m. or more: (+/-) 20 mm.

**iv) Variations in the sizes and locations of sleeves, openings in walls and floors except in the case of and for anchor bolts:**

(+/-) 5 mm.

**v) Variation in cross-sectional dimensions of columns and beams and in the thickness of slabs and walls:**

(+) 10 mm./(-) 5 mm.

**vi) Footings:**

a) Variation in dimensions in plan: (+) 50 mm./(-) 5 mm.

b) Misplacement or eccentricity: 2% of footing within the direction of misplacement but not more than 50 mm.

c) Reduction in thickness: (-) 5% of specified thickness subject to maximum of 50 mm.

**vii) Variation in steps.**

a) In a flight of stairs.

Rise: (+/-) 3.0 mm.

Tread: (+/-) 5.0 mm.

b) In consecutive steps.

Rise: (+/-) 1.5 mm.

Tread: (+/-) 3 mm.

**10.2.2 Tolerances in other Concrete Structure:**

**A) All structures:**

i) Variation of the constructed linear outline from established position in plan.

In 5 m.: (+/-) 10 mm.

In 10 m. or more: (+/-) 15 mm.

ii) Variation of dimensions to individual structure features from established positions in plan.

In 20 m. or more: (+/-) 25 mm.

In buried constructions: (+/-) 150 mm.

iii) Variation from plumb, from specified batter or from curved surfaces of all structures.

In 2.5 m.: (+/-) 10 mm.

In 5.0 m.: (+/-) 15 mm.

In 10.0 m. or more: (+/-) 25 mm.

In buried constructions: (+/-) Twice the above limits.

iv) Variation from level or grade indicated on drawings in slabs, beams, soffits, horizontal grooves and visible arises.

In 2.5 m.: (+/-) 5 mm.



- In 7.5 m. or more: (+/-) 10 mm.  
In buried constructions: (+/-) Twice the above limits.
- v) Variation in cross-sectional dimensions of columns, beams, buttresses, piers and similar members. (+) 12 mm./(-) 6 mm.
- vi) Variation in the thickness of slabs, walls, arch sections and similar members. : (+) 12 mm./(-) 6 mm.

**B) Footings for columns, piers, walls, buttresses and similar members:**

- i) Variation of dimensions in plan: (+) 50 mm./(-)12 mm.  
ii) Misplacement or eccentricity: 2% of footing within the direction of misplacement but not more than 50 mm.  
iii) Reduction in thickness: 5% of specified thickness subject to a maximum of 50 mm.

Tolerances in other types of structures shall generally conform to those given in Clause 2.4 of Recommended Practice for concrete form work (ACI 347)

**10.3 TYPE OF FORMWORK:**

Form work may be of timber, plywood, metal, plastic or concrete. For special finishes, the formwork may be lined with plywood, steel sheets, oil tempered hard board etc. Sliding forms and slip forms may be used with the approval of Engineer-in- Charge.

**10.4 FORMWORK REQUIREMENTS:**

Forms shall conform to the shapes, lines, grades and dimensions including camber of the concrete as called for in the drawings. Ample studs, waler braces, straps, shores etc. shall be used to hold the forms in proper position without any distortion whatsoever until the concrete has set sufficiently to permit removal of forms. Forms shall be strong enough to permit the use of immersion vibrators. In special cases, from vibrators may also be used. The shuttering shall be close boarded. Timber shall be well seasoned, free from sap, shakes, loose knots, worm holes, warps or other surface defects in contact with concrete. Faces coming in contact with concrete shall be free from adhering grout, plaster, paint, projecting nails, splits or other defects. Joints shall be sufficiently tight to prevent loss of water and fine material from concrete.

Plywood shall be used for exposed concrete surfaces, where called for. Sawn and wrought timber may be used for unexposed surfaces. Inside faces of forms for concrete surfaces which are to be rubbed finished shall be planned to remove irregularities or unevenness in the face. Form work with lining will be permitted.

All new and used from lumber shall be maintained in a good condition with respect to shape, strength, rigidity, water tightness, smoothness and cleanliness of surfaces. Form lumber unsatisfactory in any respect shall not be used and if rejected by Engineer-in-Charge shall be removed from the site.

Shores supporting successive stories shall be placed directly over those below or be so designed and placed that the load will be transmitted directly to them. Trussed supports shall be provided for shores that cannot be secured on adequate foundation.

Formwork, during any stage of construction showing signs of distortion or distorted to such a degree that the intended concrete work will not conform to the exact contours indicated on the drawings, shall be repositioned and strengthened. Poured concrete affected by the faulty formwork, shall be entirely removed and the formwork corrected prior to placing new concrete.

Excessive construction camber to compensate for shrinkage settlement etc. that may impair the structural strength of members will not be permitted.

Forms for substructure concrete may be omitted when, in the opinion of Engineer-in-Charge, the open excavation is firm enough to act as the form. Such excavations shall be slightly larger than required by the drawings to compensate for irregularities in excavation and to ensure the design requirement.

Forms shall be so designed and constructed that they can be stripped in the order required and their removal do not damage the concrete. Face formwork shall provide true vertical and horizontal joints, conforming to the architectural features of the structure as to location of joints and be as directed by Engineer-in-Charge.

Where exposed smooth or rubbed concrete finishes are required, the forms shall be constructed with special care so that the desired concrete surfaces could be obtained which require a minimum finish.

#### **BRACINGS, STRUTS AND PROPS:**

Shuttering shall be braced, strutted, propped and so supported that it shall not deform under-weight and pressure of the concrete and also due to the movement of men and other materials. Bamboos shall not be used as props or cross bracings.

The shuttering for beams and slabs shall be so erected that the shuttering on the sides of beams and under the soffit of slab can be removed without disturbing the beam bottoms.

Repropping of beams shall not be done except when props have to be reinstated to take care of construction loads anticipated to be in excess of the design load. Vertical props shall be supported on wedges or other measures shall be taken whereby the props can be gently lowered vertically while striking the shuttering.

If the shuttering for a column is erected for the full height of the column, one side shall be left open and built upon sections as placing of concrete proceeds, or windows may be left for pouring concrete from the sides to limit the drop of concrete to 1.0 m. or as directed by Engineer-in-Charge.

#### **10.5 INSPECTION OF FORM WORK:**

Following points shall be borne in mind while checking during erection of form work and form work got approved by the Engineer-in-charge before placing of reinforcement bars:

- a) Any member which is to remain in position after the general dismantling is done, should be clearly marked.
- b) Material used should be checked to ensure that, wrong items / rejects are not used.
- c) If there are any excavations nearby which may influence the safety of form works, corrective

---

and strengthening action must be taken.

- d)
  - i) The bearing soil must be sound and well prepared and the sole plates shall bear well on the ground.
  - ii) Sole plates shall be properly seated on their bearing pads or sleepers.
  - iii) The bearing plates of steel props shall not be distorted.
  - iv) The steel parts on the bearing members shall have adequate bearing areas.
- e) Safety measures to prevent impact of traffic, scour due to water etc. should be taken. Adequate precautionary measures shall be taken to prevent accidental impacts etc.
- f) Bracing, struts and ties shall be installed along with the progress of form work to ensure strength and stability of form work at intermediate stage. Steel sections (especially deep sections) shall be adequately restrained against tilting, overturning and form work should be restrained against horizontal loads. All the securing devices and bracing shall be tightened.
- g) The stacked materials shall be placed as catered for, in the design.
- h) When adjustable steel props are used, they should:
  - i) Be undamaged and not visibly bent.
  - ii) Have the steel pins provided by the manufacturers for use.
  - iii) Be restrained laterally near each end.
  - iv) Have means for centralizing beams placed in the foreheads.
- i) Screw adjustment of adjustable props shall not be over extended.
- j) Double wedges shall be provided for adjustment of the form to the required position wherever any settlement / elastic shortening of props occurs. Wedges should be used only at the bottom end of single prop. Wedges should not be too steep and one of the pair should be tight ended / clamped down after adjustment to prevent their shifting.
- k) No member shall be eccentric upon vertical member.
- l) The number of nuts and bolts shall be adequate.
- m) All provisions of the design and / or drawings shall be complied with.
- n) Cantilever supports shall be adequate.
- o) Props shall be directly under one another in multistage constructions as far as possible.
- p) Guy ropes or stays shall be tensioned properly.
- q) There shall be adequate provision for the movement and operation of vibrators and other construction plant and equipment.
- r) Required camber shall be provided over long spans.
- s) Supports shall be adequate, and in plumb within the specified tolerances.

#### **10.6 FORM OIL:**

Use of form oil shall not be permitted on the surface which require painting. If the contractor desire to use form oil on the inside of formwork of the other concrete structures, a non staining mineral oil

or other approved oil CEMOL-35 of Ms. Hindustan Petroleum Co. Ltd. may be used, provided it is applied before placing reinforcing steel and embedded parts. All excess oil on the form surfaces and any oil on metal or other parts to be embedded in the concrete shall be carefully removed. Before treatment with oil, forms shall be thoroughly cleared of dried splatter of concrete from placement of previous lift.

#### **10.7 CHAMFERS AND FILLERS:**

All corners and angles exposed in the finished structure shall be formed with mouldings to form chamfers or fillers on the finished concrete. The standard dimensions of chamfers and fillets, unless otherwise specified, shall be 20 x 20 mm. Care shall be exercised to ensure accurate mouldings. The diagonal face of the moulding shall be planed or surfaced to the same texture as the forms to which it is attached.

#### **10.8 VERTICAL CONSTRUCTION JOINT CHAMFERS:**

Vertical construction joints on faces which will be exposed at the completion of the work shall be chamfered as above except where not permitted by Engineer-in-Charge for structural or hydraulic reasons.

#### **10.9 WALL TIES:**

Wire ties passing through the walls, shall not be allowed. Also through bolts shall not be permitted. For fixing of formwork, alternate arrangements such as coil nuts shall be adopted at the contractors cost.

#### **10.10 REUSE OF FORMS:**

Before reuse, all forms shall be thoroughly scraped, cleaned, nails removed, holes that may leak suitably plugged and joints examined and when necessary repaired and the inside retreated to prevent adhesion, to the satisfaction of Engineer-in-charge. Warped lumber shall be resized. Contractor shall equip himself with enough shuttering to complete the job in the stipulated time.

#### **10.11 REMOVAL OF FORMS:**

Contractors shall record on the drawings or a special register, the date upon which the concrete is placed in each part of the work and the date on which the shuttering is removed there from.

In no circumstances shall forms be struck until the concrete reaches a strength of the at least twice the stress due to self-weight and any construction erection loading to which the concrete may be subjected at the time of striking formwork.

In normal circumstances (generally where temperatures are above 15 °C.) forms may be struck after expiry of the following periods:

**Stripping time:**

Sl. No.	Type of form work	Minimum period before striking form work
a)	Vertical form work to columns, walls beams	16 – 24 h
b)	Soffit form work to slabs (Props to be refixed immediately after removal of formwork)	3 days
c)	Soffit form work to beams (Props to be refixed immediately after removal of formwork)	7 days
d)	Props to slabs: 1) Spanning up to 4.5 m 2) Spanning over 4.5 m	7 days 14 days
e)	Props to beams and arches; 1) spanning up to 6 m 2) spanning over 6 m	14 days 21 days

For other cements and lower temperature, the stripping time recommended above may be suitably modified.

The number of props left under the sizes and the position shall be such as to able to safely carry the full dead load of the slab, beam or arch., as the case may be together with any live load likely to occur during curing or further constructions.

Where the shape of the element is such that the form work has the reentrant angles the form work shall be removed as soon as possible. After the concrete has set, to avoid shrinkage cracking occurring due to the restraint imposed.

Striking shall be done slowly with utmost care to avoid damage to arise and projection and without shock or vibration, by gently easing the wedges. If after removing the formwork, it is found that timber has been embedded in the concrete, it shall be removed and made good as specified earlier.

Reinforced temporary openings shall be provided, as directed by Engineer-in-Charge, to facilitate removal of formwork which otherwise may be in-accessible.

Tie rods, clamps, form bolts etc. which must be entirely removed from walls or similar structures shall be loosened not sooner than 24 hours nor later than 40 hours after concrete has been deposited. Ties, except those required to hold forms in place, may be removed at the same time. Ties withdrawn from walls and grade beams shall be pulled towards the inside face. Cutting ties back from the faces of walls and grade beams will not be permitted. Work damaged due to premature or careless removal of forms shall be re-constructed at contractors cost.

**10.12 MODE OF MEASUREMENT:**

In case the items of concreting are inclusive of cost of form work, no separate measurements shall be taken for form work. However, if the form work is to be paid separately and the item exists in the Schedule of Quantities for various types of form work, the net area of exposed surface of concrete



members as shown in drawings coming in contact with form work shall be measured under item of formwork in square meters.

All temporary formwork such as bulk heads, stop boards provided at construction joints which are not shown in the drawings shall not be measured.

No deductions shall be made for openings/ obstructions up to an area of 0.1 sqm. and nothing extra shall be paid for forming such openings.

The rate shall include the cost of erecting, centering, shuttering materials, transport, deshuttering and removal of materials from site and labour required for all such operations etc.

---

## **XI. STRUCTURAL STEEL:**

### **11.1 SCOPE OF WORK:**

The work covered by this specification consists of furnishing and erecting of structural steel complete in strict accordance with this specifications and the applicable drawings.

### **11.2 MATERIALS:**

**11.2.1** All structural steel shall be of standard sections as marked on the drawings and shall be free of scale, blisters, laminations, cracked edges and defects of any sort. If the structural steel is not supplied by the Department and the Contractor is required to bring such steel, the Contractor shall furnish duplicate copies of all mill orders and/ or also the test report received from the mills, to satisfy the Engineer-in-Charge.

**11.2.2** All structural steel and electrodes shall comply in all respects with I.S.S. for structural steel.

### **11.3 WORKMANSHIP:**

All workmanship shall be of first class quality in every respect to the greatest accuracy being observed to ensure that all parts will fit together properly on erection.

All ends shall be cut true to planes. They must fit the abutting surfaces closely.

All stiffeners shall be fit tightly at both ends.

All butt ends of compression members shall be in close contact through the area of the joints.

All holes in plates and section between 12 mm. and 20 mm. thick shall be punched to such diameter that 3 mm. of metal is left all around the hole to be cleaned out to correct size by reamer.

The base connection shall be provided as shown on drawings and the greatest accuracy of workmanship shall be ensured to provide the best connections.

Figured dimensions on the drawings shall be taken.

### **11.4 ERECTION AND MARKING:**

Erection and fabrication shall be according to I.S. 800-1984 section-11. During erection, the work shall be securely braced and fastened temporarily to provide safety for all erection stresses etc. No permanent welding shall be done until proper alignment has been obtained.

Any part which do not fit accurately or which are not in accordance with the drawings and specifications shall be liable to rejection and if rejected, shall be at once be made good.

Engineer-in-Charge shall have full liberty at all reasonable times to enter the contractors premises for the purpose of inspecting the work and no work shall be taken down, painted or dispatched until it has been inspected and passed. The contractor shall supply free of charge all labour and tools required for testing of work.

### **11.5 DELIVERY AT SITE:**

The contractor shall deliver the component parts of the steel work in an undamaged state at the site of the works and the Engineer-in-Charge shall be entitled to refuse acceptance of any portion which has been bent or otherwise damaged before actual delivery on work.

### **11.6 SHOP DRAWINGS:**

The shop drawings of structural steel based on contract drawings shall be submitted to the Engineer-in-Charge. The necessary information for fabrication, erection, painting of structure etc. must be furnished immediately after acceptance of the tender.

### **11.7 PAINTING:**

Painting should be strictly according to I.S. 1477-1971 (Part I-Pretreatment) and I.S. 1477-1971 (Part II-painting).

Painting should be carried out on dry surfaces free from dust, scale etc. The paint shall be approved by the Engineer-in-Charge.

One coat of shop paint (red lead) shall be applied on steel, except where it is to be encased in concrete or where surfaces are to be field welded.

### **11.8 WELDING:**

Welding shall be in accordance with I.S. 816-1969, I.S. 819-1957, I.S. 1024-1979, I.S. 1261-1959, I.S. 1323-1982 and I.S. 9595-1980 as appropriate. For welding of any particular type of joint, welders shall give evidence of having satisfactory completed appropriate tests as described in any of I.S. 817-1966, I.S. 1393-1961, I.S. 7307 (Part-I)-1974, I.S. 7310 (Part-I)-1974 and I.S. 7318 (Part-I)-1974 as relevant.

**11.8.1 Welding Consumables:** Covered electrodes shall conform to I.S. 814 (Part-I)-1974 and I.S.814 (Part-II)-1974 or I.S. 1395-1982 as appropriate.

Filler rods and wires for gas welding shall conform to I.S. 1278-1972.

The bare wire electrodes for submerged arc welding shall conform to I.S. 7280-1974. The combination of arc and flash shall satisfy the requirements of I.S. 3613-1974.

The filler rods and bare electrodes for gas shielded metal, arc welding shall conform to I.S. 6419-1971 and I.S. 6560-1972 as appropriate.

**11.8.2 Types of Welding:** Arc welding (direct or alternating current) or Oxyacetylene welding may be used. Field welding may be used. Field welding shall be by D.C.

**11.8.3 Size of Electrode Runs:** The maximum gauge of the electrodes for welding any work and the size of run shall be based on the following tables.



<b>Average thickness of plate or section</b>	<b>Maximum gauge or diameter of electrodes to be used.</b>
Less than 3/16"	10 S.W.G.
3/16" and above but less than 5/16"	8 S.W.G.
5/16" and above but less than 3/8"	6 S.W.G.
3/8" and above but less than 5/8"	4 S.W.G.
5/8" and above but less than 1"	5/16" dia.
1" and above thick section	3/8" dia.

**Note:** On any straight weld the first run shall not ordinarily be deposited with a larger gauge electrode than No. 8 S.W.G. For subsequent runs the electrode shall not be increased by more than two electrode size between consecutive runs.

**11.8.4 Welding Contractors:** The contractor shall ensure that each welding operator employed on fabrication or erection is an efficient and dependable welder, who has passed qualifying tests on the types of welds which will be called upon to make. Sample test shall have to be given by the contractor to the entire satisfaction of the Engineer-in-charge.

**11.8.5 Welding Procedure:**

a) Welding should be done with the structural steel in flat position in a down hand manner wherever possible. Adequate steps shall be taken to maintain the correct arc length, rate of travel, current and polarity for the type of electrode and nature of work. Welding plant capacity shall be adequate to carry out the welding procedure laid down. Adequate means of measuring the current shall be available either as a part of the welding plant or by the provision of a portable ammeter. In checking the welding current, a tolerance of 10% or 30 amperes from the specified value whichever is less shall be permitted.

b) The welding procedure shall be such as to ensure that the weld metal can be fully and satisfactory deposited through the length and thickness of all joints so that distortion and shrinkage stresses are reduced to the minimum and thickness of welds meet the requirements of quality specified.

**11.9 WORKMANSHIP:**

**11.9.1 Preparation of Fusion Faces:** Fusion faces shall be cut by steering machine or gas cutting and later dressed by filing or grinding so that they shall be free from irregularities such as would interfere with the deposition of the specified size of weld to cause the defects. Fusion faces and the surrounding surfaces shall be free from heavy slag, oil paint or any substance which might affect the quality of the weld or impede the progress of welding. The welding face shall be free of rust and shall have metal shine surfaces.

The parts to be welded shall be brought into as close contact as possible and the gap due to faulty workmanship or incorrect fit up shall not exceed 1/16". If separation of 1/16" or more occurs locally, the size of the fillet weld shall be increased at such position by an amount of equal to the width of the

gap.

The parts to be welded shall be maintained to their correct position during welding. They shall be securely held in position by means of tack welds, service bolts, clamps or rings before commencing welding so as to prevent and relative movement due to distortion, wind or any other cause.

**11.9.2 Step Back Method should be used to Avoid Distortion:** The minimum leg length of a fillet weld as deposited should not be less than the specified size and the throat thickness as deposited should be not less than that tabulated below:

**Throat Thickness of Fillet**

Angle between fusion faces	60 <sup>0</sup> -90 <sup>0</sup>	91 <sup>0</sup> -100 <sup>0</sup>	101 <sup>0</sup> -106 <sup>0</sup>	107 <sup>0</sup> -113 <sup>0</sup>	114 <sup>0</sup> -120 <sup>0</sup>
Throat thickness in cms.	0.70	0.65	0.60	0.55	0.50

In no case should a concave weld be deposited without the specific approval of the Engineer-in-Charge unless the leg length is increased above the specified length so that the resultant throat thickness is as great as would have been obtained by the deposition of a flat.

All welds shall be deposited in a pre-arranged order and sequence taking due account of the effects of distortion and shrinkage stresses.

After making each run of welding, all slag shall be removed and final run shall be protected by clean boiled linseed oil till approved.

The weld metal, as deposited, shall be free from crack, slag, excessive porosity, cavities and other faults.

The weld metal shall be properly fused with the parent metal without overlapping or serious undercutting at the toes of the weld.

The surfaces of the weld shall have a uniform and consistent contour and regular appearance.

In welds containing crack, porosity or cavities in which the weld metal tends to overlap on the parent metal without proper fusion, the defective portions of the welds shall be out cut and re-welded. Where serious under cutting occurs, additional weld metal shall be deposited to make good reduction. Testing of welded joints shall be done as per relevant IS codes 3600, 3613, 4260, 7205, 7215, 7307, 7310, 7318.

**11.10 MODE OF MEASUREMENT:**

All structural steel shall be measured on weight basis in metric tonnes or quintals or kgs. As mentioned in the schedule of quantities. The length or areas of various members including gusset plates shall be measured correct to two places of decimals and the net weight worked out from the standard steel tables approved by Indian Standard Institution. No separate measurements shall be taken for welding, riveting, bolting, field connections etc. The rate shall include cost of all labour, materials, scaffolding, transport and also cost of welding, riveting and bolting, field connections if any all to complete the job as per specifications.

**SECTION - VIII**

**DRAWINGS**

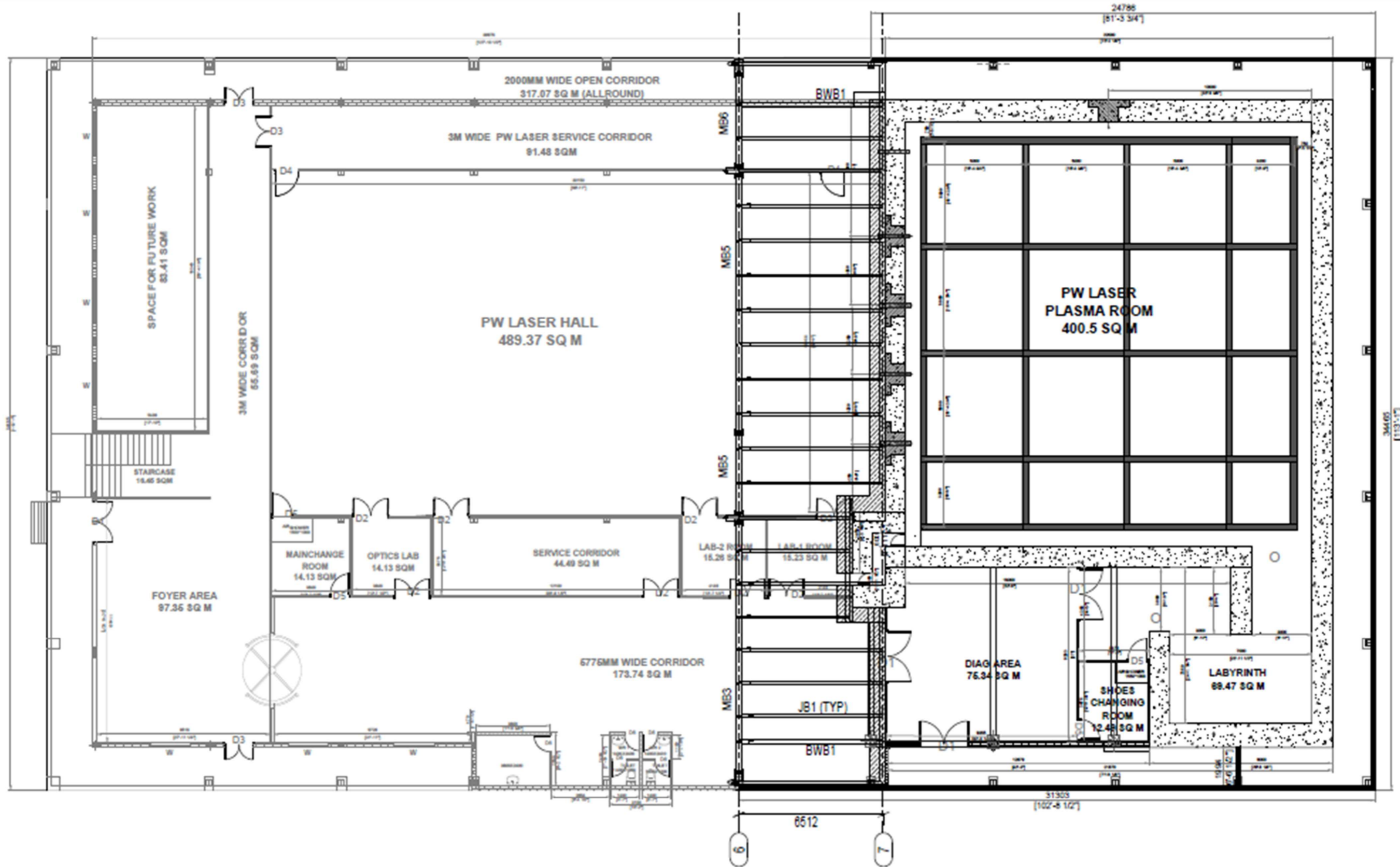

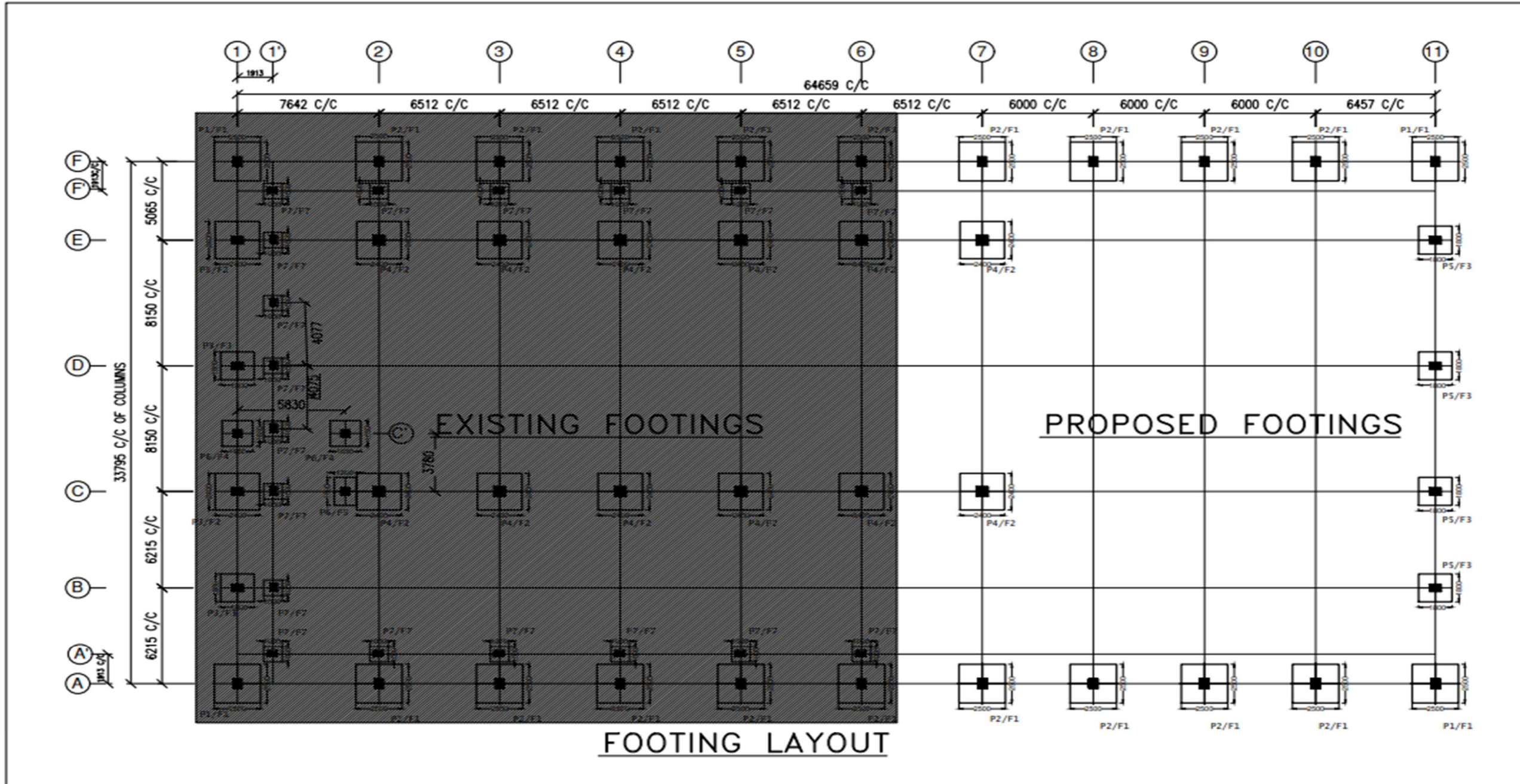

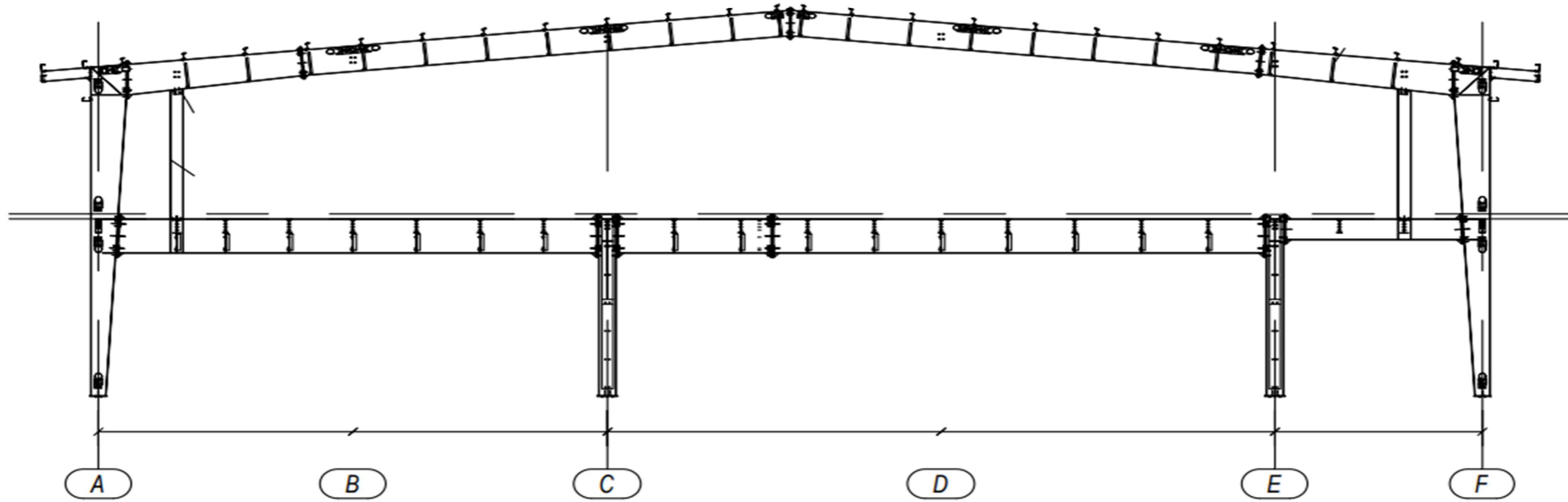

CROSS SECTION FORM GRID 6 TO 7

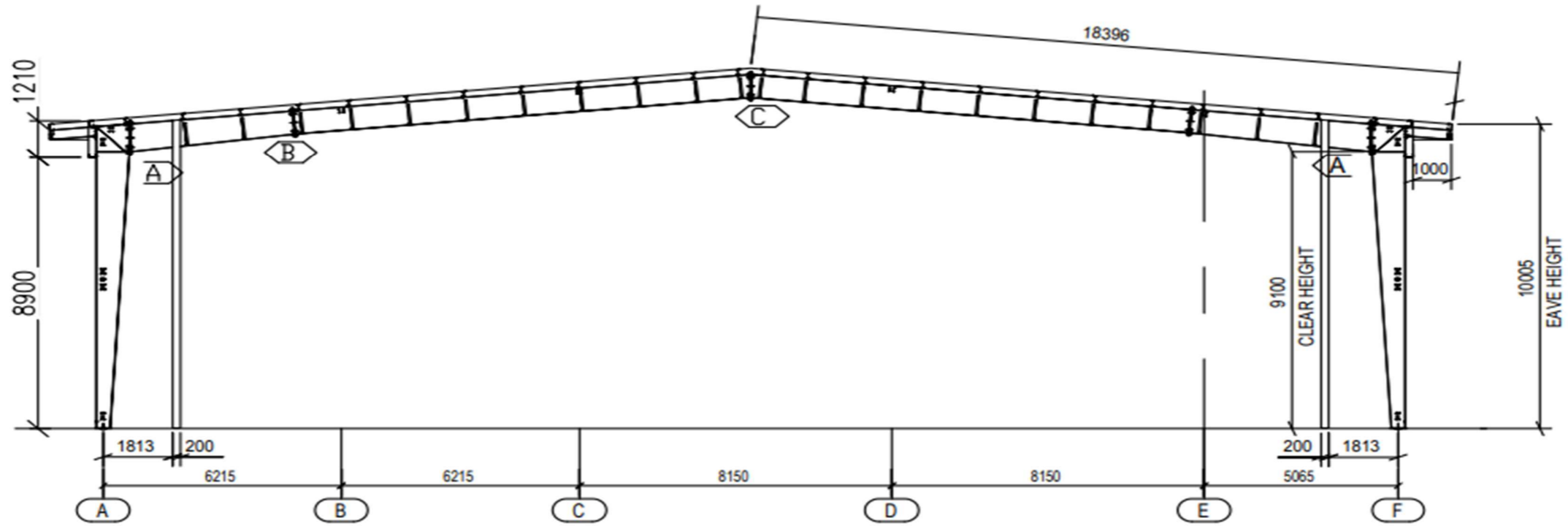

**CROSS SECTION ALONG GRID-8 to 10**

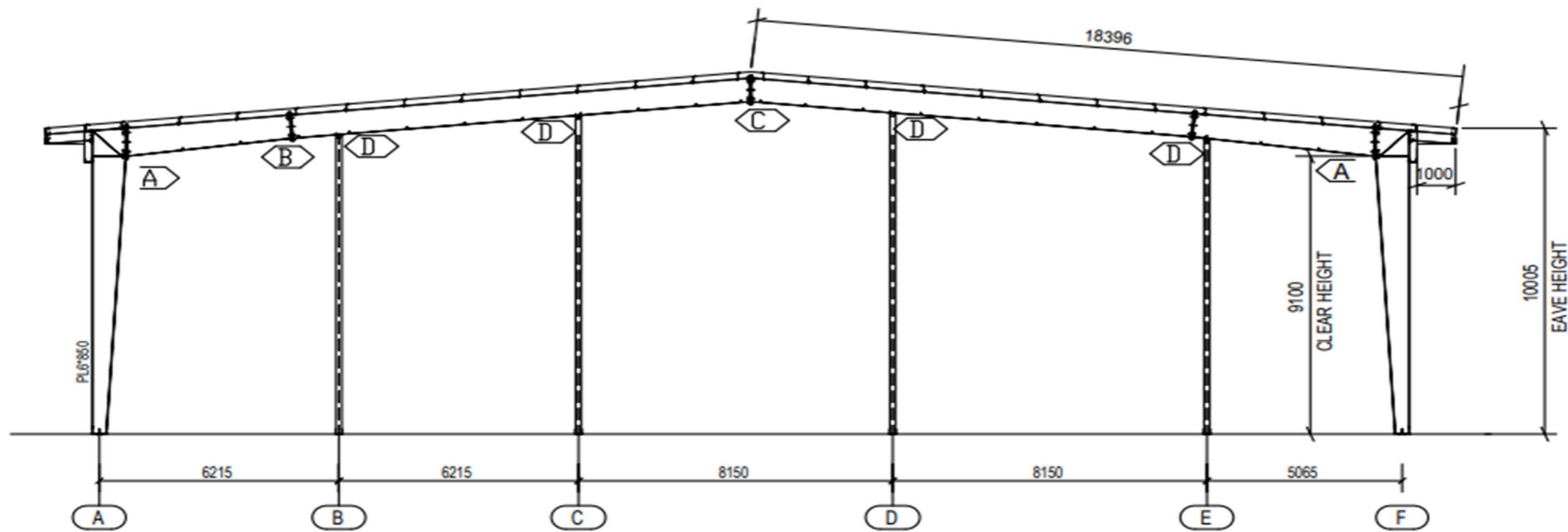

**CROSS SECTION ALONG GRID - 11**



**SECTION - IX**

**ANNEXURES**

**Annexure-I**

**BANK GUARANTEE FORMAT FOR SECURITY DEPOSIT**

(To be submitted on appropriate value of Non-Judicial stamp paper from any Scheduled Bank)

ORDER NO. \_\_\_\_\_ DTD. \_\_\_\_\_

To,  
 Centre Director  
 TIFR, Survey No. 36/P, Gopanpally (Village),  
 Serilingampally (Mandal),  
 Ranga Reddy Dist, Hyderabad-500046.

This deed of guarantee executed on the \_\_\_\_\_ day of \_\_\_\_\_  
 by the \_\_\_\_\_ (bank)  
 (hereinafter referred to as "The Bank: which expression shall wherever the context so requires or  
 admits means and includes its successors and assigns).

WHEREAS M/s. - \_\_\_\_\_ having  
 their registered office at \_\_\_\_\_  
 (hereinafter called "the Vendor/Contractor/Supplier") have conveyed to the Centre Director, TIFR,  
 Hyderabad acceptance of the Purchase Order / Work Order (whichever is applicable)  
 No. \_\_\_\_\_ Dated \_\_\_\_\_ for  
 the  
 (Hereinafter called the "Vendor/Contractor/Supplier").

In accordance with the terms as set out in the above quoted Purchase Order / Work Order, you  
 have agreed to accept a bank guarantee for Rs. \_\_\_\_\_ (Rs. \_\_\_\_\_  
 \_\_\_\_\_ only) equivalent to \_\_\_\_\_ (percent) of the value of the contract in lieu of  
 security deposit to be valid upto \_\_\_\_\_ or any extension that may be  
 agreed to. For this purpose, you have agreed to accept our Guarantee.

In consideration thereof, we hereby (Bank), at the request of M/s. \_

\_\_\_\_\_ Irrecoverably and unconditionally undertake and guarantee to refund to the Centre Director,  
 TIFR, Hyderabad on behalf of the said Vendor/Contractor/Supplier a sum of Rs. \_\_\_\_\_  
 on demand and without any demure against any loss or damage that may be suffered by the  
 TIFR, Hyderabad on receipt of your intimation that the M/s. \_\_\_\_\_  
 Have for no reason failed to comply with any of the terms and conditions of the said contract.

This guarantee shall be valid till (the date of completion of the work contained in the said order) as  
 certified by you or till any extension of the date as may be agreed to by us. In the event, the  
 guarantee shall expire 30 days after the said order is satisfactorily completed by you as conforming  
 to the terms and conditions of the contract.

This guarantee shall not be revoked without your express consent and shall not be affected by



you granting time or any other indulgence to M/s. \_\_\_\_\_ which shall include but not be limited to postponement from time to time if the exercise of any power vested in you or any right that you may have against to exercise the same in any manner at any time and either to enforce any covenant contained or implied in the said contract or any other course or remedy or security available to you and our bank shall not be released from its obligation under this bank guarantee by your exercising any of your rights with regard to matters aforesaid or any of them or by reason of any other act or forbearance or other act of omission or commission on your part or any other indulgence shown by you or any other matter or thing whatsoever which under law would but for this provision have the effect of relieving our bank from its obligation under this guarantee.

We shall agree that you shall be entitled at your option to enforce this guarantee against our bank as a principal debtor by a mere demand in writing from you which shall be conclusive evidence to us that such repayment is due and payable to you under the terms of the said contract and shall be binding on us notwithstanding any other security or guarantee that you may have in relation to M/s. \_\_\_\_\_ liabilities in respect of this premises.

This guarantee shall not be affected by any change in the constitution of our bank or of the companies or for any other reason whatsoever.

Not with standing anything herein contained our liability under this guarantee is restricted to Rs. \_\_\_\_\_ (Rupees\_

\_\_\_\_\_ only) and the guarantee will remain in force up to \_\_\_\_\_ or any extension that may be agreed to unless a demand or claim is filled against us on or before that said date of expiry viz. \_\_\_\_\_

all your rights under this guarantee shall be forfeited and we shall be relieved and discharged from all liabilities hereunder.

IN WITNESS WHEREOF, the undersigned being duly authorized by the Directors of the Bank has hereunto set his hand at \_\_\_\_\_ this \_\_\_\_\_ day.

**SIGNATURE OF BANK OFFICIAL WITH CODE**

- Bank Address :
- Name :
- Land Line No. :
- Mobile No. :
- Email address :
- Rubber Stamp :

SIGNATURE OF WITNESS: 1.





**Annexure-II**  
**FORM OF AGREEMENT**

This Agreement is made on the \_\_\_\_\_ day of \_\_\_\_\_  
2023 \_\_\_\_\_ between Tata Institute Of  
Fundamental Research(TIFR), Hyderabad for the entering into work(s) for '**Construction of Civil Super  
Structure and Interior for National Center for Nutrition and metabolism**' at Plot-B, TIFR, Survey No.  
36/P, Gopanpally (Village), Serilingampally (Mandal), Ranga Reddy Dist., Hyderabad-500 046, Telangana,  
India' (hereinafter called "The Employer") who enters into this Agreement of the one part and  
M/s \_\_\_\_\_(herein after called "The  
Vendor/Contractor/Supplier") of the other part.

Whereas the Employer is desirous that certain works should be executed by the  
Vendor/Contractor/Supplier, viz \_\_\_\_\_  
("the Works")and has accepted a Bid by the Vendor/Contractor/Supplier for the execution and completion  
of the works and the remedying of any defects therein.

Now this Agreement witnessed as follows:

1. In this Agreement words and expressions shall have the same meanings as are respectively assigned to them in the Conditions of Contract hereinafter referred to.
2. The following documents shall be deemed to form and be read and construed as part of this Agreement, viz:
  - (a) The Letter of Award;
  - (b) The said Bid;
  - (c) The General Conditions of Contract;
  - (d) Prequalification document
  - (e) Instructions to Bidders and Specific Conditions of Contract;
  - (f) The Specification;
  - (g) The Drawings;
  - (h) The Price Bid
  - (i) Any other relevant documents referred to in this Agreement or in the aforementioned documents.
3. In consideration of the payments to be made by the Employer to the Vendor/Contractor/Supplier as hereinafter mentioned, the Vendor/Contractor/Supplier hereby covenants with the Employer to execute and complete the Works and remedy any defects therein in conformity in all respects with the provisions of this work.
4. The Employer hereby covenants to pay the Vendor/Contractor/Supplier in consideration of the execution and completion of the Works and the remedying of defects therein the Contract Price or only such other sums as may become payable under the provisions of the Contract at the times and in the manner prescribed by the Contract.

In Witness whereof the parties hereto have caused this Agreement to be executed the day and year first before written. Signed, Sealed, and Delivered by the Said.

Binding Signature for and on behalf of TIFR-Hyderabad.

Binding Signature of Vendor/Contractor/Supplier \_\_\_\_\_ In  
the presence of  
Witness (1):

Witness (2):



**ANNEXURE -III**

**PROFORMA FOR PERFORMANCE BANK GURANTEEE**

(On a stamp paper of appropriate value from any Nationalized Bank or Scheduled Bank)

1. In consideration of the TATA INSTITUTE OF FUNDAMENTAL RESEARCH (TIFR) having agreed under the terms and conditions of Work Order No.....dated made between TIFR, Hyderabad and M/s.....(hereinafter called "The said Vendor/Contractor/Supplier{s} ") for the work(hereinafter called "the said Work Order") having agreed to production of an irrevocable bank Guarantee for Rs (Rupees..... only), as a security / guarantee from the Vendor/Contractor/Supplier(s) for compliance of his obligations in accordance with the terms and conditions in the said Work Order, we. (Indicate the name of the Bank) (Hereinafter referred to as "The Bank") hereby undertake to pay to the TIFR, Hyderabad an amount not exceeding Rs.....(Rs.....only) on demand by the TIFR, Hyderabad.
2. We (indicate the name of Bank) do hereby undertake to pay the amounts due and payable under this guarantee without any demur, merely on a demand from the TIFR, Hyderabad stating that the amount claimed is required to meet the recoveries due or likely to be due from the said Vendor/Contractor/Supplier(s). Any such demand made on the bank shall be conclusive as regards the amount due and payable by the Bank under this guarantee. However, our liability under this guarantee shall be restricted to an amount not exceeding Rs..... (Rupees only).
3. We, the said bank, further undertake to pay to the TIFR, Hyderabad any money so demanded notwithstanding any dispute or disputes raised by the Vendor/Contractor/Supplier(s) in any suit or proceeding pending before any Court or Tribunal relating thereto, our liability under this present being absolute and unequivocal. The payment so made by us under this bond shall be a valid discharge of our liability for payment thereunder and the Vendor/Contractor/Supplier(s) shall have no claim against us for making such payment.
4. We (indicate the name of Bank) further agree that the guarantee herein contained shall remain in full force and effect during the period that would be taken for the performance of the said Work Order and that it shall continue to be enforceable till all the dues of the TIFR, Hyderabad under or by virtue of the Work order have been fully paid and its claims satisfied or discharged or Purchase Officer on behalf of the TIFR, Hyderabad certifies that the terms and conditions of the said Work Order have been fully and properly carried out by the said Vendor/Contractor/Supplier(s) and accordingly discharges this guarantee.
5. We (indicate the name of Bank) further agree with the TIFR, Hyderabad that the TIFR, Hyderabad shall have the fullest liberty without our consent and without affecting in any manner our obligations hereunder to vary any of the terms and conditions of the said Work Order or to extend time of performance by the said Vendor/Contractor/Supplier(s) from time to time or to postpone for any time or from time to time any of the powers exercisable by the TIFR, Hyderabad against the said Vendor/Contractor/Supplier(s) and to forbear or enforce any of the terms and conditions relating to the said Work Order and we shall not be relieved from our liability by reason of any such variation, or extension being granted to the said Vendor/Contractor/Supplier(s) or for any forbearance, act of omission on the part of the TIFR, Hyderabad or any indulgence by the TIFR, Hyderabad to the said Vendor/Contractor/Supplier(s) or by any such matter or thing whatsoever which under the law relating to sureties would, but for this provision, have effect of so relieving us.
6. This guarantee will not be discharged due to the change in the constitution of the Bank or the Vendor/Contractor/Supplier(s).
7. We, (indicate the name of Bank) lastly undertake not to revoke this guarantee except with the previous consent of the TIFR, Hyderabad in writing.
8. This guarantee shall be valid up to....., unless extended on demand by TIFR, Hyderabad. Notwithstanding anything mentioned above, our liability against this guarantee is restricted to Rs..... (Rupees only) and unless a claim in writing is lodged with us within six months of the date of expiry or the extended date of expiry of thisguarantee, all our liability under this guarantee shall stand discharged.

Signed and sealed Dated the.....day of 2023 for  
 ..... (Indicate the name of Bank)

\*\* (Note: The Letter of Intent shall form part of the Agreement)



**Annexure-IV**  
**Site Visit Declaration Certificate**  
**(To be submitted on company's letter head)**

CERTIFICATE OF TENDERER'S VISIT TO SITE

1. This is to certify that I \_\_\_\_\_(Name of bidder or his Representative) am from \_\_\_\_\_(Name of Firm of tendering) visited the site at TIFR, Hyderabad in connection with the Tender for **Construction of Civil Super Structure and Interior for National Center for Nutrition and metabolism** at Plot-B, TIFR, Survey No. 36/P, Gopanpally (Village), Serilingampally (Mandal), Ranga Reddy Dist., Hyderabad-500046, Telangana, India.
2. Having previously studied the contract documents, I carefully examined the site.
3. I have made myself familiar with all the local conditions likely to influence the works and the cost thereof.
4. I further certify that I am satisfied with the description of the work and the explanations given by the said Representative and that I understand perfectly the work to be done as specified and implied in the execution of the contract.

Signed by tendering firm representative and name:

Signed by tenderer and name:

Date: \_\_\_\_\_

### Annexure-V

#### List of Documents to be enclosed along with the bid submission:

01	Proof of registration with Government / Semi Government organizations like CPWD, MES, BSNL, Railways, State PWDs etc. in appropriate class OR having experience in execution of similar nature of works.	
02	The applicant should have satisfactorily completed the works as mentioned below during the last <b>seven years ending previous day of last date of submission of tenders</b> : (i) One work costing not less than Rs.114.57 Lakh ( <b>or</b> ) (ii) Two works each costing not less than Rs.85.93 lakh ( <b>or</b> ) (iii) Three works costing not less than Rs.57.28 lakh ( <b>Work completion certificates along with work order and BOQ</b> )	
03	Annual Turnover during three previous <b>financial years</b> ending March 31, 2023 duly certified by CA <b>and</b> also provide P&L Statements.	
04	PAN & GST copies of the Firm	
05	A valid Labour License / Declaration	
06	Income Tax returns for the last three consecutive financial years ended on March 31, 2023 audited by CA	
07	A valid Solvency Certificate for note less than Rs.57.28 lakhs	
08	Undertaking by the Tenderer as per the specified format	
09	Site Visit Declaration Certificate	
10	Acceptance of Terms & Conditions of the tender by signing every page of the tender document with stamp.	
11	Details of Tender Fee & EMD	

Please fill and enclose this sheet along with technical documents.

## Annexure-VI

### List of Approved Makes

Sl. No.	Name of Material	Make
	<b>Civil Items</b>	
1 (a)	Cement (Portland Pozzolana Cement)	ACC, Ultra Tech., Birla cements, or Equivalent.
1 (b)	Cement (Ordinary Portland Cement)	ACC, Ultra Tech., Birla cements, or Equivalent.
2	Reinforcement Steel	TATA, SAIL, RINL, JINDAL or any BIS approved License holder/ manufacturer
3	Structural Steel	TATA, SAIL, RINL, JINDAL or any BIS approved License holder/ manufacturer



**SECTION - X**

**FINANCIAL BID**

**INVITATION OF BIDS  
FOR**

**Construction of Roof Covering Shed for Beam Hall at  
Plot B, TIFR, Survey No. 36/P, Gopanpally Village, Serilingampally  
Mandal, Ranga Reddy District, Hyderabad.**

**FINANCIAL BID**

**PART –II**

**SCHEDULE OF QUANTITIES**

**Construction of Roof Covering Shed for Beam Hall at Plot B, TIFR Survey No. 36/P,  
 Gopanpally Village, Serilingampally Mandal, Ranga Reddy District, Hyderabad.**

Sr.No.	Item Description	Unit	Qty	Unit Price	Total Price in INR
1	<b>SITE CLEARANCE:</b> Site Clearance including uprooting of rank vegetation, grass, brushwood, trees and saplings of girth upto 30cm measured at a height of 1m above ground level, clearing grass, including disposal of rubbish upto a distance of 5 Km outside the periphery of the area cleared etc. complete all as per the directions of Engineer - in - Charge..	Sqm	600.00		
2	<b>EXCAVATION:</b> Earthwork in excavation below Ground Level in all kinds of soils up to hard strata to a maximum depth of 2.5 m below existing FGL; staking out of work as per specifications; taking spot levels on edges & centreline @ 3m c/c as per specifications; bailing out of water if encountered; providing side strutting if required, segregating the excavated earth in to serviceable and unserviceable earth; stacking the serviceable earth separately for enabling reuse for backfilling or any other purpose as per instructions of TIFR-TCIS, HYDERABAD; carting away and disposing the unserviceable earth and disposing off beyond site boundaries to suitable dumping spots/unobjectionable places; obtaining approval from Mining Department/Applicable departments by payment of royalty; Right of way payments; loading at TIFR-TCIS, HYDERABAD premises; transportation to dumping spots/unobjectionable places; unloading & levelling at dumping spots/unobjectionable places; For depth up to and including 2.5 M	Cum	650.00		
3	<b>BACK FILLING:</b> Backfilling around sub-structure with serviceable & reusable soils available from excavation and stacked earlier within the new site boundary including re-excavating, shifting to the site of backfilling, backfilling in layers of 200 mm; watering; compacting; testing to achieve 95% MDD as per lab results all complete as per instructions of TIFR-TCIS, HYDERABAD. UPTO 2.0 M	Cum	550.00		

4	<p><b>BASEMENT FILLING:</b>          Basement filling in plinth with selected earth excavated from nearby borrow areas identified by statutory authorities including excavation, all leads, lifts, loading, unloading, stacking, levelling, spreading, in layers not exceeding 150 mm thick, breaking clods, watering, consolidation to obtain 90% proctor density etc. complete as per specifications, drawings &amp; as directed by the Engineer in Charge.</p>	Cum	361.00		
5	<p><b>ANTITERMITE TREATMENT:</b>          Supply, diluting and injecting approved quality chemical emulsion in sealed containers with emulsifiable concentrate of 20% with 1% concentration for PRE-CONSTRUCTIONAL Anti-Termite Treatment and creating a continuous chemical barrier (Only ground floor plinth area of the building will be measured for payment).The work shall be carried - out by specialised agency and as per IS 6313 (Part II 2001). The anti - termite treatment shall be guaranteed for a period of 10 (Ten) Years.</p>	Sqm	361.00		
6	<p><b>PLAIN CEMENT CONCRETE:</b>          Supplying and Laying Plain Cement Concrete of Grade 1:4:8 with stone aggregate of 40mm down size (including shuttering if required) in all levelling courses under Foundation, Floors, Pipelines, Pits, trenches etc., at all depths complete all as per Drawings and Specifications and instruction of the Engineer.</p>	Cum	60.00		
7	<p><b>REINFORCED CEMENT CONCRETE WITH SHUTTERING:</b>          Providing and laying in position M-25 grade concrete for reinforced cement concrete work, using cement content as per approved design mix, <b>Including the cost of cantering</b>, shuttering finishing, cost of admixtures in recommended proportions as per IS : 9103 to accelerate/ retard setting of concrete, improve workability without impairing strength and durability as per direction of the Engineer - in - charge. (Note: - Cement content considered in this item is @ 330 kg/cum. Excess/less cement used as per design mix is payable/recoverable separately).</p> <p><b>M-25 Grade Design Mix Concrete, using 20 mm downgraded coarse aggregate IN SUB-STRUCTURE</b>  <b>RMC Make: Ultratech, Engineer's Concrete or equivalent</b></p>	Cum	75.00		



8	<p><b>REINFORCEMENT STEEL:</b>          Supplying and Fabricating and Fixing in position TMT Steel Reinforcements of Grade Fe-500 conforming to IS at all levels and positions including the Cost of transport, Straightening, Cutting, Bending, Cranking, Binding, Welding, Provision of necessary Chairs and Spacers, Preparation of bar bending schedule, Drawings, getting the same approved etc., as per Drawings and Specifications and including Cost of binding wire, Labor etc., all complete for Reinforced Concrete. Only approved chairs, spacers &amp; overlaps shall be used.</p> <p><b>a) Thermo-Mechanically Treated bars Fe-500.Make:TATA steel/RINL/sail and equivalent.</b></p>	MT	9.00		
9	<p><b>FOUNDATION BOLT:</b>          Supply and fixing of Foundation bolt of 4.6 grade as per the drawings &amp; instructions of Engineer in charge.          Make:TATA steel/RINL/sail and equivalent.</p>	Ton	0.50		
10	<p><b>RANDOM RUBBLE MASONRY:</b>          Providing and Construction of <b>Random rubble masonry</b> with hard stone in foundation and plinth including levelling up with cement concrete 1:6:12 (1 cement : 6 coarse sand : 12 graded stone aggregate 20 mm nominal size) upto plinth level with Cement mortar 1:6 (1 cement : 6 coarse sand) etc., complete all as per the directions of the Engineer - in - charge.</p>	Cum	130.00		
11	<p><b>DAMP PROOF COURSE:</b>          Laying DPC upto 50 mm thick with plain cement concrete (1:2:4) prop nominal mix using 10 mm downgraded machine crushed HBG metal including c/c of all materials, cost of seignorage charges on all materials, using approved water proofing admixture conplast 421 IC of <b>M/S FOSROC or equivalent</b> at rate of 150 ml per one bag of cement, laying, labour etc. and other incidental works complete.</p>	Sqm	30.00		
12	<p><b>CONCRETE FOR PLINTH PROTECTION:</b>          Supplying and Laying Plain Cement Concrete of following Grades (including Shuttering if required) in Plinth Protection, foundation, floors, aprons, pits, drains and other mass Concrete works, Steps, Coping of wall etc., at all level as per Drawings, Specifications and instruction of Engineer.b) 1:2:4 Grade Concrete using 20, mm downgraded coarse aggregate.</p>	Cum	20.00		

<b>MS-STRUCTURE WORK</b>					
13	<p><b>STRUCTURAL STEEL WORK(Supply and Fabrication) :</b>            Supplying, fabricating, HS structural steel works similar to Pre-Engineering building structures using columns, canopies, rafter , sub rafters and Purlins at all elevations/levels/heights including aligning/leveling, providing and fixing bolts, nuts, washers, angles, channels, joists, rails, tees, plates, rounds, squares,etc., of various sizes and other structural steel sections conforming to latest IS 2062-Grade A &amp; B as applicable including straightening, cutting, welding, bending to shape, bolting, cleaning the rust and scales. Scope is inclusive of following finishes ie.Grit / sand blasting and applying one coat of Red Oxide Primer DFT 30 Microns and synthetic enamel paint DFT 35 microns. Only paint touchup wherever needed to be done after erection.            The rate to include the cost of all materials, labours, tools, tackles, cranes, devices, fasteners, welding, connection required for work shop and packing pieces, fabrication in the work shop, transportation to site as per specifications and drawing complete.(E350 Grade material)            Make: JSW, Tata Steel,RINL,SAIL etc with ISI</p>	Ton	60.00		
14	<p><b>STRUCTURAL STEEL WORK(Erection) :</b>            Hoisting and erecting in position HS structural steel works similar to Pre-Engineering building structures using columns, canopies, rafter , sub rafters and Purlins at all elevations/levels/heights including aligning/leveling, providing and fixing bolts, nuts, washers, angles, channels, joists, rails, tees, plates, rounds, squares,etc., of various sizes and other structural steel sections conforming to latest IS 2062-Grade A &amp; B as applicable            The rate to include the cost of all tools, tackles, cranes, devices, fasteners and erection at site as per specifications and drawing complete.</p>	Ton	60.00		
15	<p><b>GALVALUME SHEET FOR ROOFING :</b>            Providing and fixing Colour Coated Galvalume sheet Jindal/ Kirby/any approved make for roofing of 1000/1020mm cover width, 28 to 30mm high crests at 250/255mm centers in lengths upto 12m to suit site requirements, in hot dip metallic coated steel. Sheet to have wide pans with three stiffening ribs for efficient water shedding and special male female sides</p>	Sqm	1000.00		

	with full return leg on side lap for supports from purlins at Ends and anticapillarity flute in side lap. The material shall be cold rolled steel, 550Mpa yield stress (ASTM A446 Grade E) With hot dipped metallic coating of aluminium Zink alloy (150gms/sqm total of both sides, AZ 150 as per ASTM A792 or AS per IS 1397),0.5mm total coated thickness. The rate should be inclusive of laps, wastages, scaffoldings, screws, fasteners, shifting of materials etc. complete for finished item of work .(Laps either with same or with other Galvalume sheet will not be considered for payment). Make: JSW, Tata BlueScope, etc with ISI				
16	<b>Providing and fixing COLOUR COATED GALVALUME SHEET for downtake,gutter:</b> The material shall be cold rolled steel,550Mpa yield stress (ASTM A446 Grade E ) With hot dipped metallic coating of aluminium Zink alloy (150gms/sqmtotal of both sides, AZ 150 as per ASTM A792 or AS per IS 1397), 0.5mm total coated thickness. The rate should be inclusive of las, wastages, preparation of shop drawings, scaffoldings, screws, fasteners, fabrication, transportation and erection at site complete.(Laps either with same or with other roofing materials will not be considered for payment). The Quoted rate should be inclusive of single/double scaffolding with safety net below the working area to suit the safety working condition at site for rain water gutters, flashings and down take pipes. Make: JSW, Tata Bluescope, etc with ISI				
16.A	i) Downtake	Rmt	120.00		
16.B	ii) Gutter	Rmt	60.00		
17	<b>Providing and fixing BARE GALVALUME SHEET for Ridge:</b> The material shall be cold rolled steel, 550Mpa yield stress( ASTM A446 Grade E ) With hot dipped metallic coating of aluminium Zink alloy ( 150gms/sqm total of both sides, AZ 150 as per ASTM A792 or AS per IS 1397), 0.5mm total coated thickness. The rate should be inclusive of fabrication, transportation, laps, wastages, preparation of shop drawings, scaffoldings, screws, fasteners, erection at siteetc complete.( Laps either with same or with other Galvalume sheet will not be considered for payment)	Rmt	30.00		

	The Quoted rate should be inclusive of single/double scaffolding with safety net below the working area to suit the safety working condition at site and as per drawing. <b>Make: JSW, Tata Bluescope, etc with ISI</b>				
18	<b>Supply &amp; fixing of Structural deck sheet:</b> Deck sheet shall be 0.8mm thick GI system having minimum rib depth of 50mm & effective cover width of 960mm having embossments on the top of the flange & side of ribs, profile shall have a zinc coating of 275g/SqM and steel grade confirming to 550mpa fixed to structural steel girders with the help of shear struds in between and edge from and steel bracket end and with necessary butt welding joint of two sheets to be jointed at structural steel girders all complete as per the direction of Engineer-in-Charge. The shear struds, edges form, steel brackets, shall be placed at required height. The rates also inclusive of edge angle of 250 x 150 x 4 mm. <b>Make: JSW, Tata Bluescope, etc with ISI</b>	Sqm	250.00		
				<b>TOTAL IN RS.</b>	
					<b>GST @ 18%</b>
				<b>GRAND TOTAL IN RS.</b>	

**Note 1: TIFR, Hyderabad has right to delete any of above items from scope of work or may increase/reduce quantities as per its requirement during execution of work. No claim or compensation for such deletion/increase/decrease will be accepted/paid to contractor. Payment will be made as per actual quantities executed at tender rates. Note**

**2: Site must be clean and remove all the debris after completion of work.**